



CHANGE MANAGEMENT PROCESS for the PUBLIC SIGNALS in SPACE (SiS) DOCUMENTS

Captain Neil Petersen
*Chief, Engineering Requirements
Branch*
SMC/GPER

20 Sep 2011



- **Purpose & Objective**
- **High Level Process Flow**
 - **Four Phase Overview**
- **Technical Baselines Change Management**
 - **Phase Decomposition**
- **Question & Answers Session**

Technical Baseline Change Management Process

Purpose & Objective



- **Purpose-** To provide the public community an overview on how the GPS Directorate manages change to the technical baseline in the public Signals in Space (SiS) documents.
- **Objective-** For the public community to be able to have the knowledge of:
 - Process
 - Relevant organizations & personnel
 - Schedulesassociated with implementing change against the public documents (IS-GPS-200, 705, and 800)



Change Management High Level Process Flow

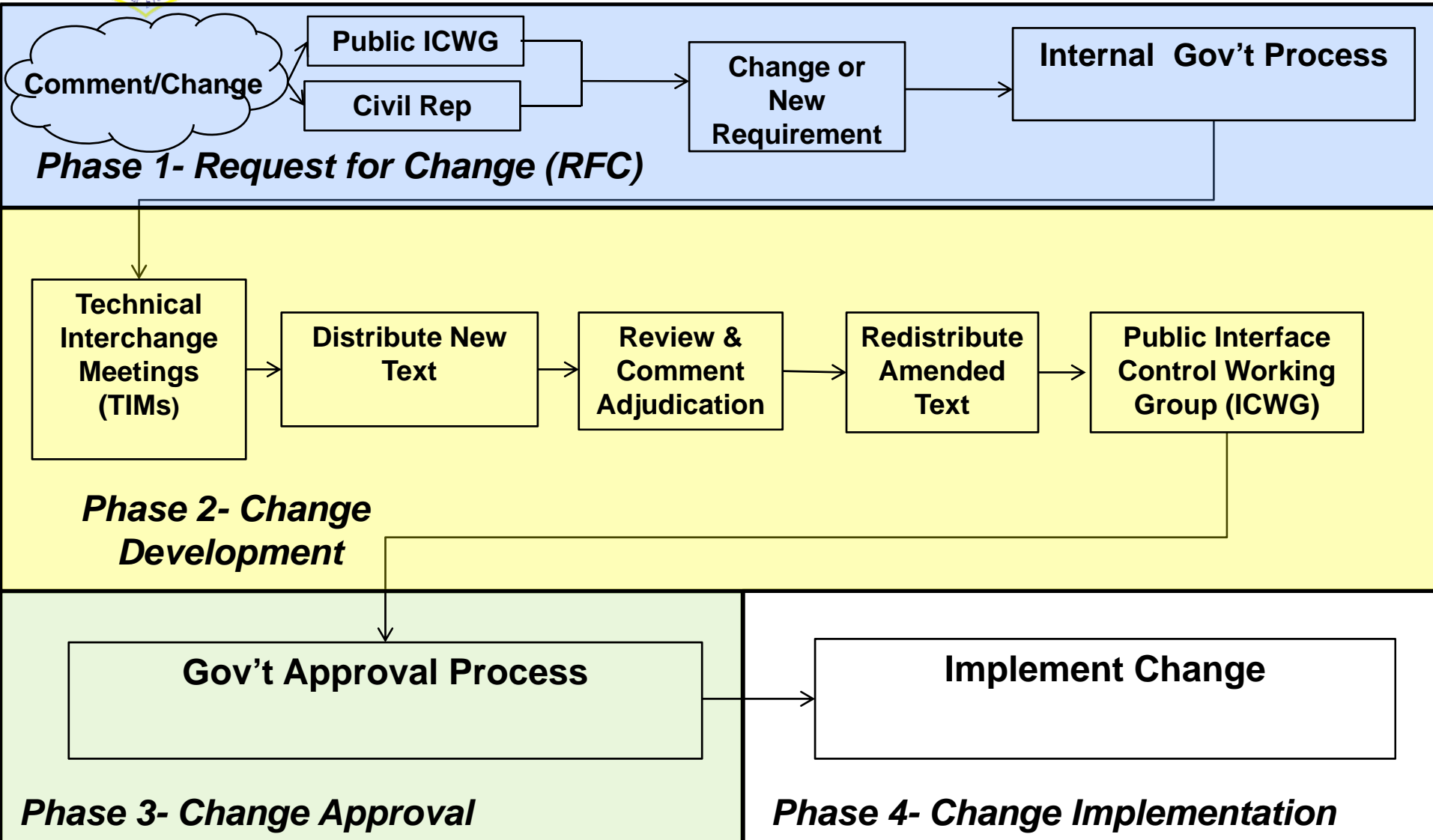



Phase 1- Request For Change (RFC)

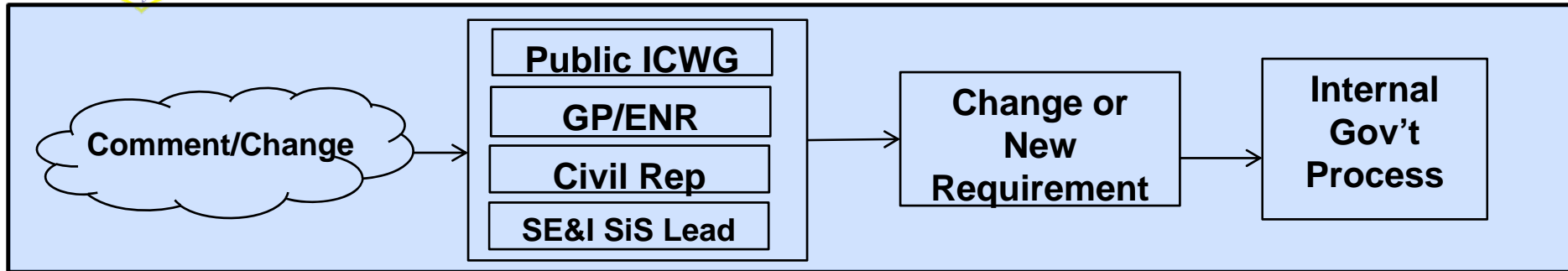

Request for Change (RFC)- a comment to identify problems, potential risks, and defined solutions.

How to submit a change?

An change/comment may be initiated by anyone in the public community – in order to be incorporated into the upcoming ICWG, comments must be received NLT **6 months prior** to ICWG.

- Public Interface Control Working Group (ICWG)- <http://www.gps.gov/technical/ICWG/>
 - Submit item during open forum discussion at the public ICWG
- GPS Engineering Requirements Branch email address- SMCGPER@losangeles.af.mil
 - Email is sent to Gov't Agency in charge of public ICWG
- GPS Civil Representative (Thomas Nagle)- thomas.nagle@losangeles.af.mil
 - Email is sent to GPS Directorate Civil Representative
- GPS Signals in Space (SiS) Documents Lead- mark.marquez.ctr@losangeles.af.mil
 - Email is sent to GPS Directorate SE&I Representative



Phase 2- Change Development- Part 1

Technical
Interchange
Meetings
(TIMs)

Distribute New
Text

Comment
Review &
Adjudication

Redistribute
Amended
Text

Public Interface
Control Working
Group (ICWG)

- **Technical Interchange Meetings (TIMs)**
 - Develop changes with appropriate stakeholders
 - Consensus on change from TIM members
- **Distribute New Text**
 - Divided in Change Categories
 - Published on GPS.gov- <http://www.gps.gov/technical/icwg/>
 - Federal Registry post
 - Meeting invitations distributed
- **Comment Review & Adjudication**
 - Stakeholder review of proposed text
 - **45 day review period**
 - Public can submit new comments **only** against the listed categories



Phase 2- Change Development- Part 2



- **Redistribute Amended Text**
 - GPS.GOV repost
 - Comments will be posted
 - Federal Registry repost
- **Public Interface Control Working Group (ICWG)**
 - Discussion includes the Directorate and the public community
 - Divided into Change categories
 - Open Forum comments used for following revision of document



Phase 3- Change Approval

Gov't Approval Process

- **Upon completion of the change development process, the Gov't collaborates with the Contractors to assess:**
 - **Technical Impact**
 - **Financial Impact**
 - **Programmatic Impact**



Phase 4- Change Implementation

Implement Change

- **Based on your comment, the Directorate and the Contractors have agreed on a specification that will be:**
 - **Implemented into hardware**
 - **Written into code**



Question & Answer Session

- **Public Interface Control Working Group (ICWG)-**
<http://www.gps.gov/technical/ICWG/>
 - **Submit item during Open Forum Discussion at the Public ICWG**
- **GPS Engineering Requirements Branch-**
SMCGPER@losangeles.af.mil
 - **Email is sent to Gov't Agency in charge of Public ICWG**
- **GPS Civil Representative (Thomas Nagle)-**
thomas.nagle@losangeles.af.mil
 - **Email is sent to GPS Directorate Civil Representative**
- **Lead Engineer- GPS Signals in Space (SiS) Documents-**
mark.marquez.ctr@losangeles.af.mil
 - **Email is sent to GPS Directorate SE&I Representative**

Backup Charts





Four-Phase Change Implementation Approach

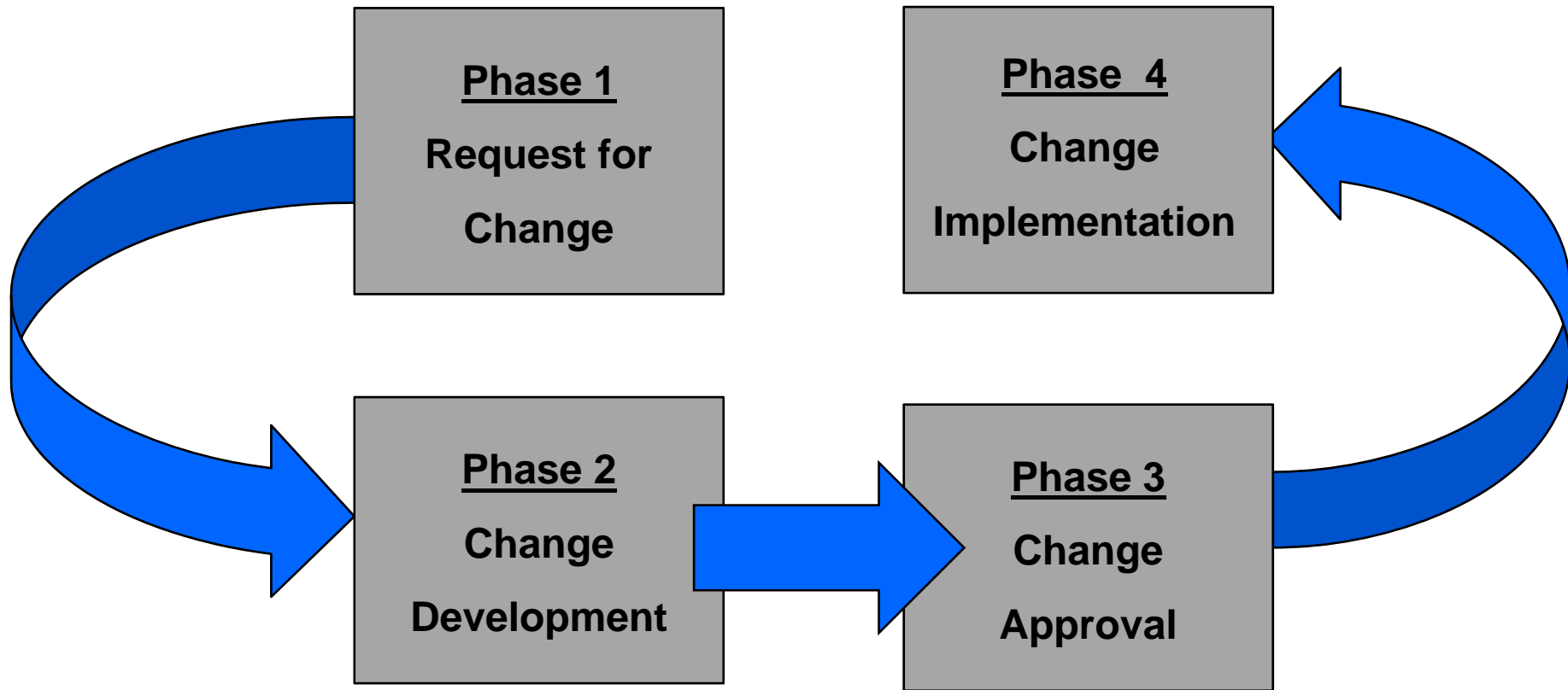

Change or New Requirement

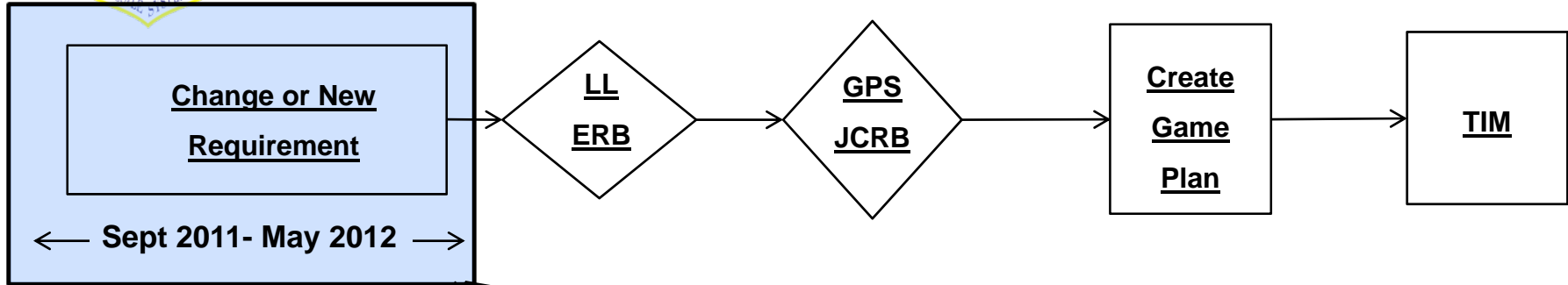

- **Membership: Anyone**
- **Comments are accepted from ~ Changes initiated within the Segment /IPT may take the form of an RFC or “Change Idea”**
- **IPT members notify CM to obtain a unique identifier (tracking number) for the change**
- **IPT members complete the RFC or “Change Idea” and submit to CM for review and Lower Level ERB (LL ERB) scheduling**

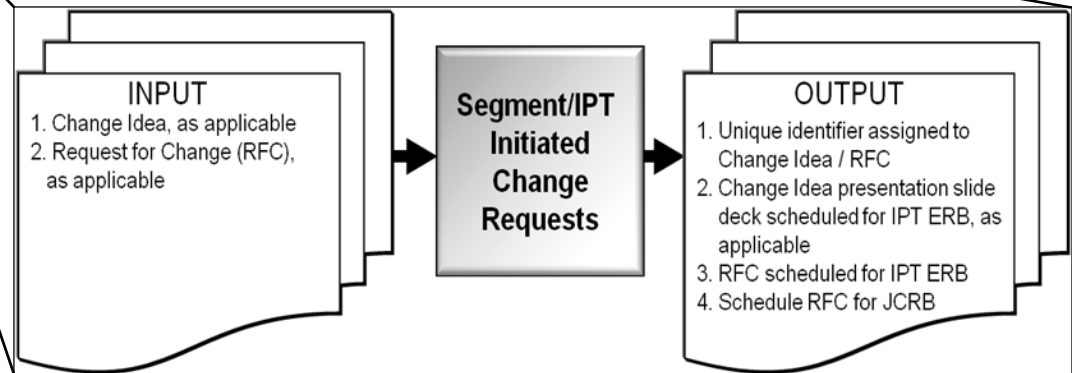

Lower Level ERB (LL ERB)

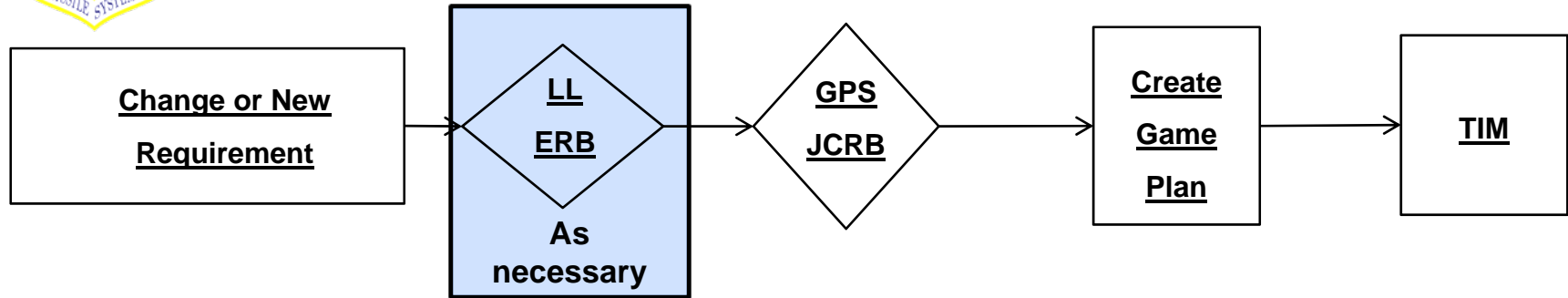

- **Membership:** Commenter, Segment IPT, SiS RE
- **Technical review and discussion of proposed changes**
- **Confirm IPT sponsorship, driver event, need dates, change priority.**
- **Determine if the “Change Idea” is necessary and whether resources should be released to further assess impacts and technical feasibility.**

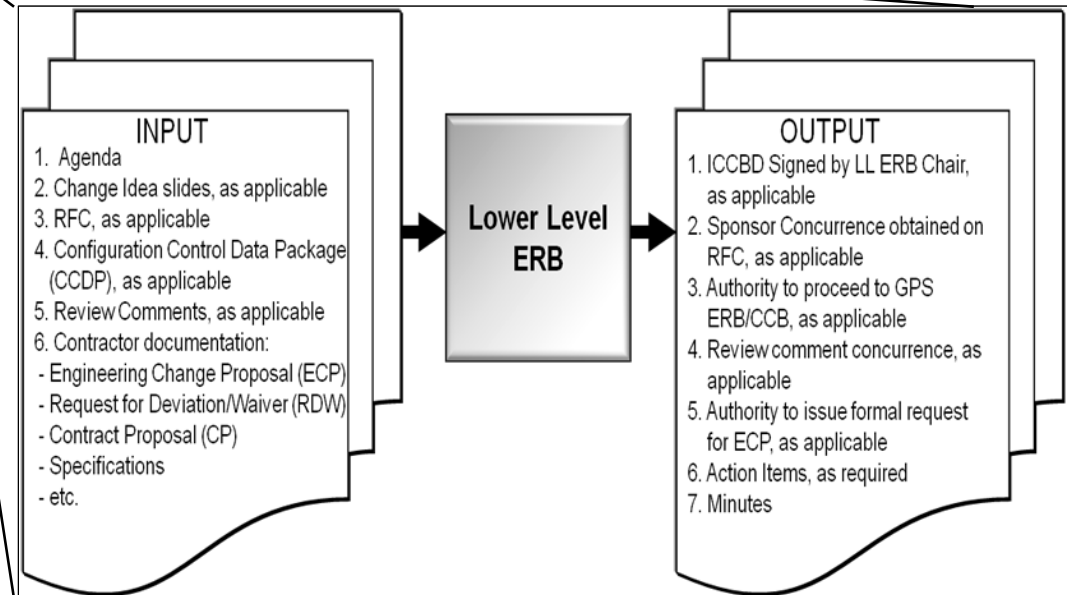

Joint Change Review Board (JCRB)

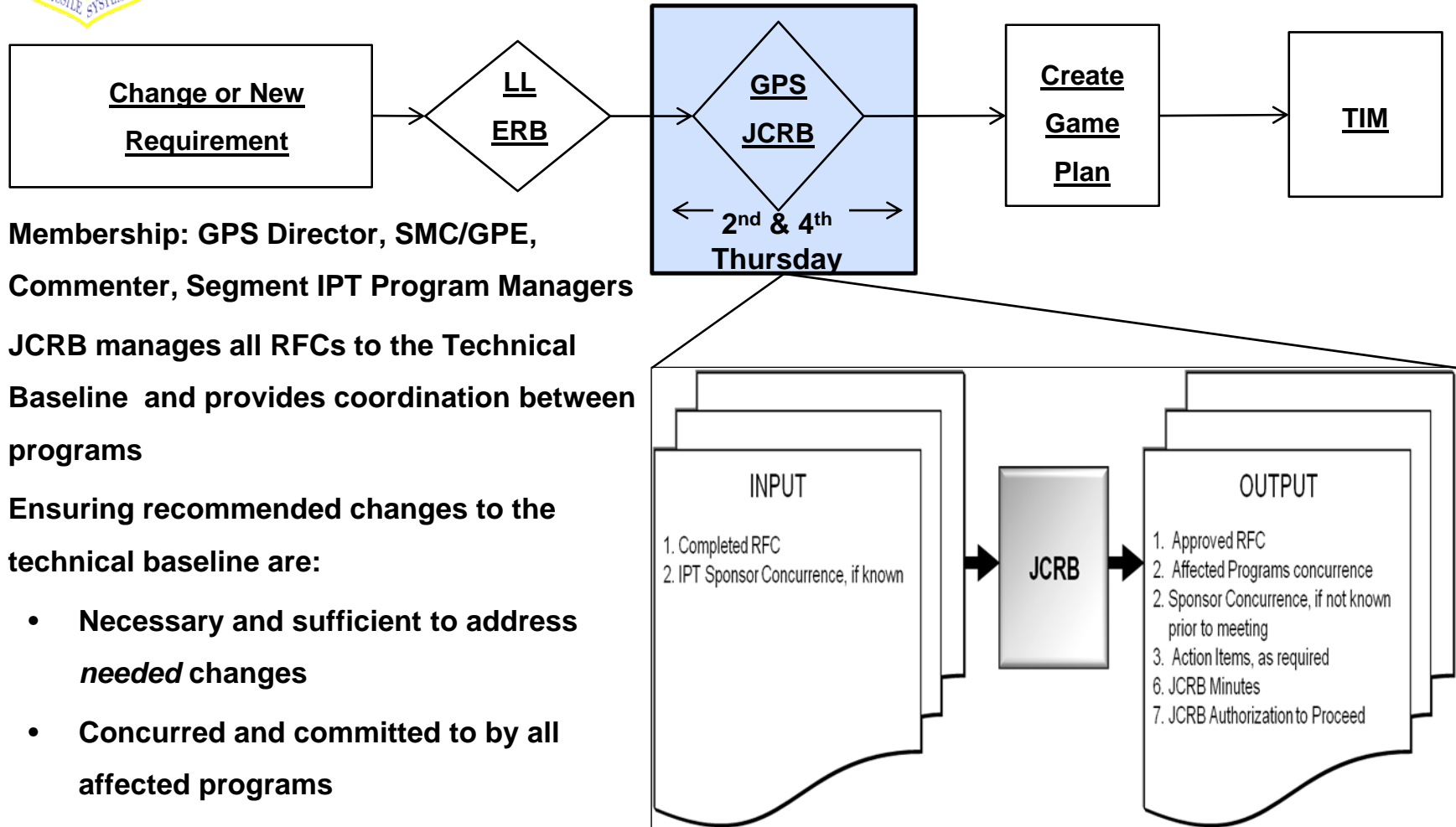

- **Membership:** GPS Director, SMC/GPE, Commenter, Segment IPT Program Managers
- JCRB manages all RFCs to the Technical Baseline and provides coordination between programs
- Ensuring recommended changes to the technical baseline are:
 - **Necessary and sufficient to address needed changes**
 - **Concurred and committed to by all affected programs**
- JCRB firmly sets the:
 - **Sponsor, Driving program event, Proposed change scope, Need date**



Technical Interchange Meeting (TIM)

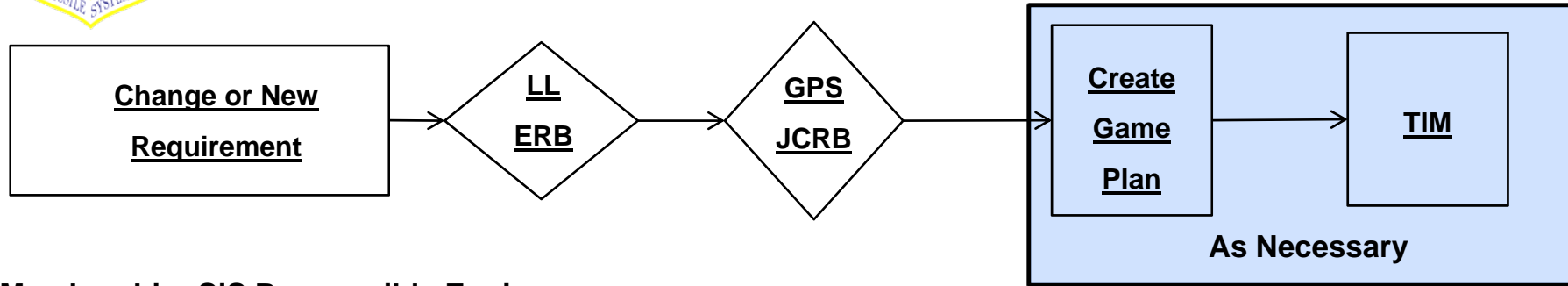

- **Membership:** SiS Responsible Engineer, Commenter, Stakeholders
- **Held prior to Combined Stakeholder/Directorate Review**
- **Provides forum for open communication between the ICC, stakeholders and signatories**
- **Addresses scope as defined on JCRB approved RFC**
- **Defines and shapes new or changing requirement**

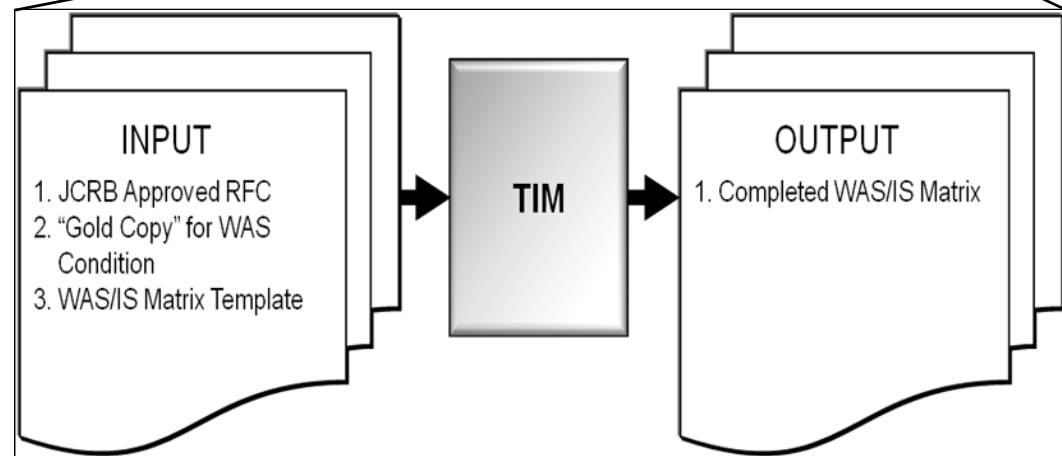

Public Affairs Process

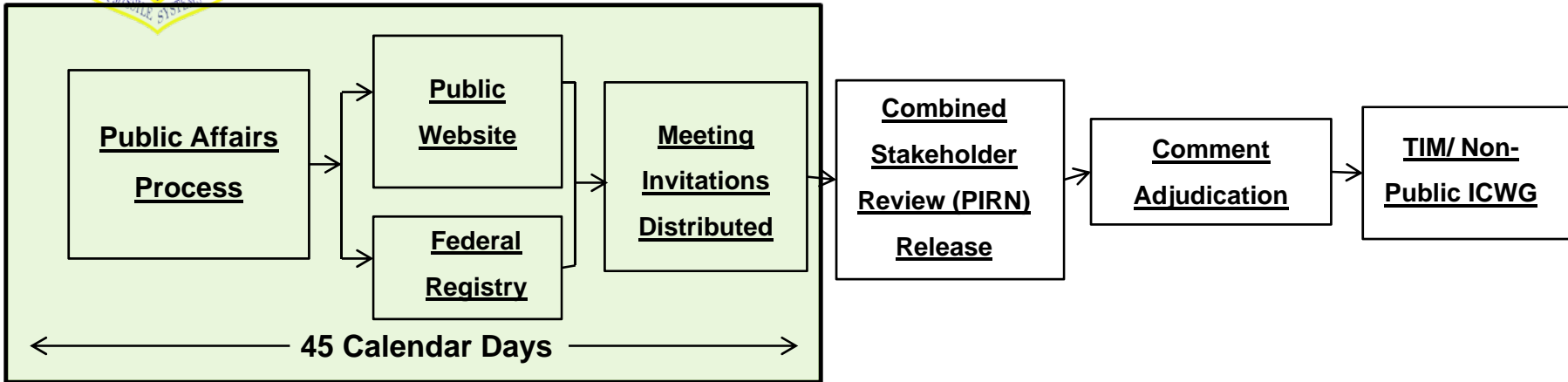

- Membership: Commenter, Precision, Navigation, Timing (PNT Office), Federal Registry
- Send documents to Precision, Navigation, and Timing (<http://www.gps.gov>) website
 - PIRN
 - WAS/IS Matrices
 - Comment Resolution Matrixes
- Send Federal Registry:
 - Meeting invitations containing ICWG Date, Time, Location
 - Comment Due Date
 - RSVP Registration Information

Combined Stakeholder/Directorate Review

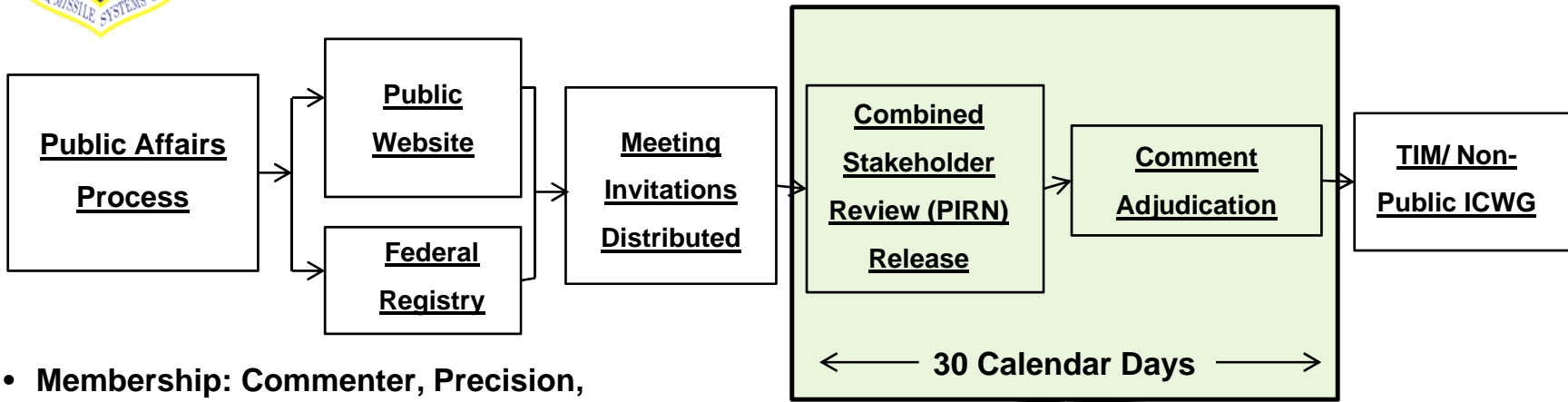

- **Membership:** Commenter, Precision, Navigation, Timing (PNT Office), Federal Registry
- The purpose of the combined stakeholder/directorate review is to obtain:
 - Comments from the 16 directorate offices)
- **Proposed Interface Revision Notice (PIRN)** as scoped on the JCRB approved RFC, before the change language is formally accepted at the Interface Control Working Group (ICWG)

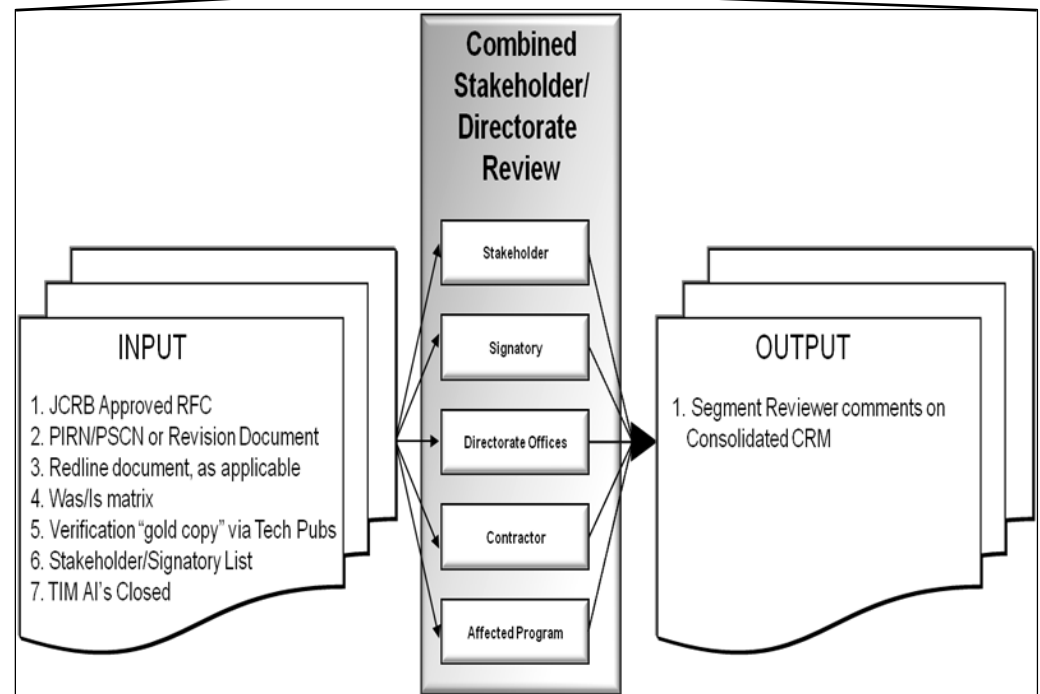



Technical Interchange Meeting (TIM)/ Non-Public Interface Control Working Group (ICWG)

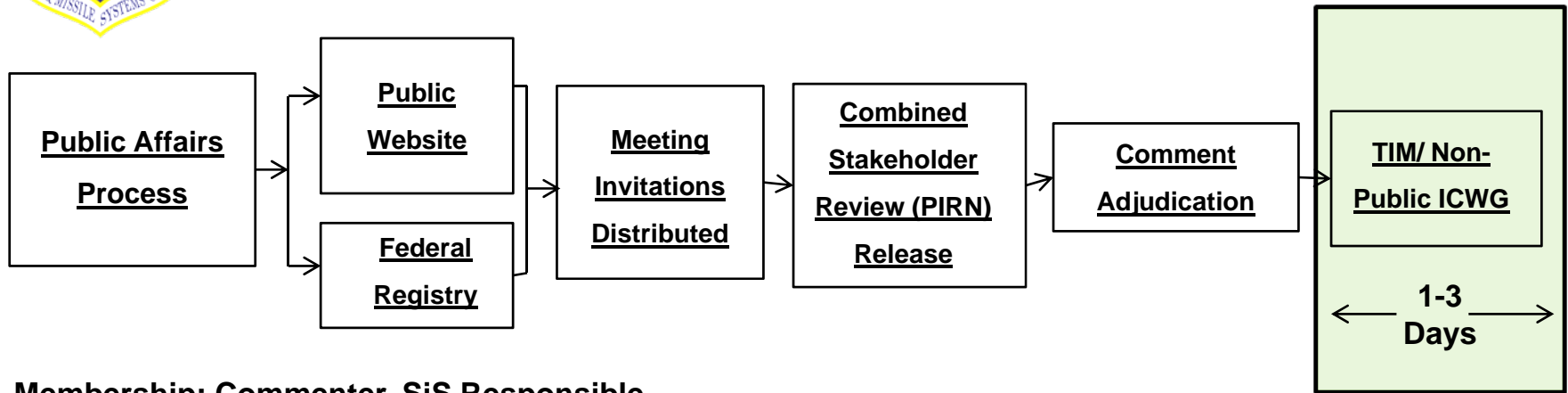

- **Membership:** Commenter, SiS Responsible Engineer, Stakeholders
- ICWGs are either *public* or *non-public* depending on the interface.
- **Non-public:**
 - **Not open to civilian organizations.**
 - **Limited to the applicable Government and contractors.**
 - **Documentation not posted on Federal Register, or GPS Public ICWG internet website.**

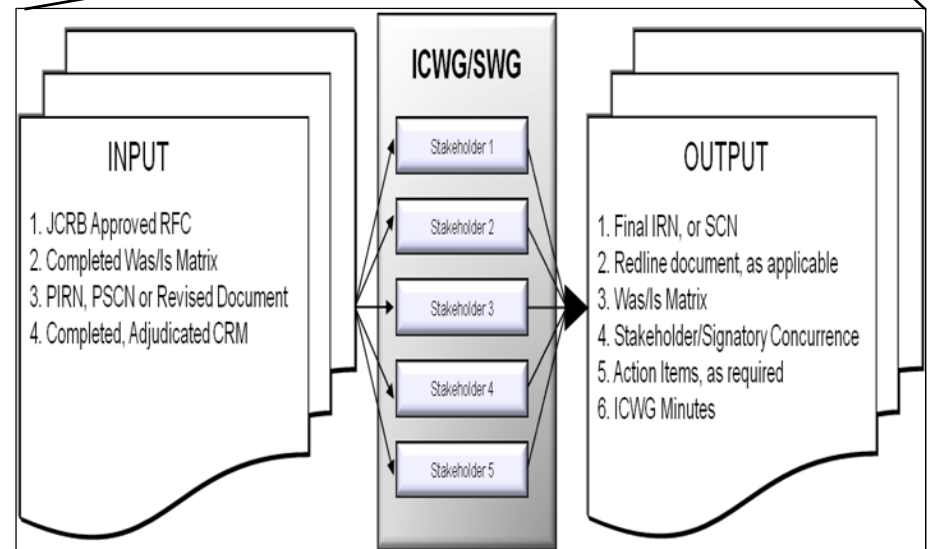

Public Affairs Process

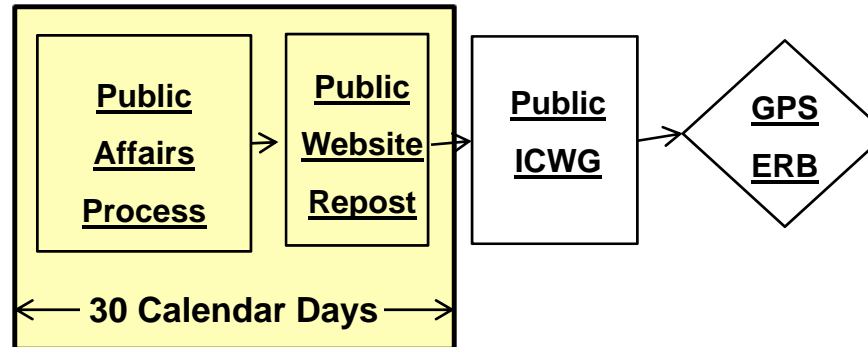

- **Membership: Commenter, Precision, Navigation, Timing (PNT Office), Federal Registry**
- **Send documents to Precision, Navigation, and Timing (<http://www.gps.gov>) website**
 - **PIRN**
 - **WAS/IS Matrices**
 - **Comment Resolution Matrixes**
- **Send Federal Registry:**
 - **Meeting invitations containing ICWG Date, Time, Location**
 - **Comment Due Date**
 - **RSVP Registration Information**



Public Interface Control Working Group (ICWG)

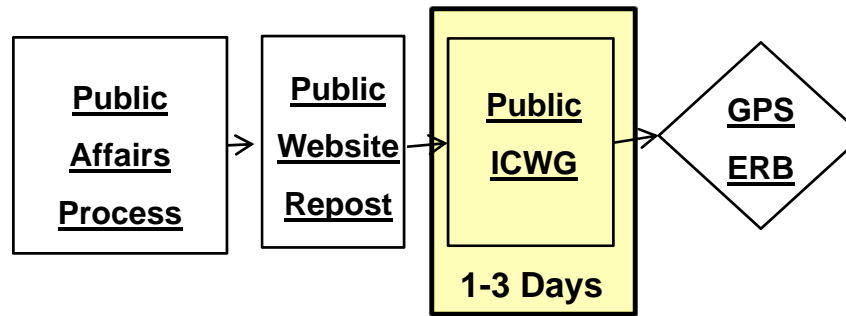

- **Membership:** Commenter, Precision, Navigation, Timing (PNT Office), Federal Registry
 - **Public ICWGs are open to all applicable civilian organizations.**
 - Focused specifically on documents that are releasable to the public.
 - **Formal ICWG announcement posted on Federal Register.**
 - **Require additional coordination of documentation through the Federal Register, SMC and GPS Public Affairs prior to posting to websites at <http://www.gps.gov> and <http://www.navcen.uscg.gov>**
 - **Formal announcement posted on Federal Register.**

Directorate Level GPS Engineering Review Board (ERB)

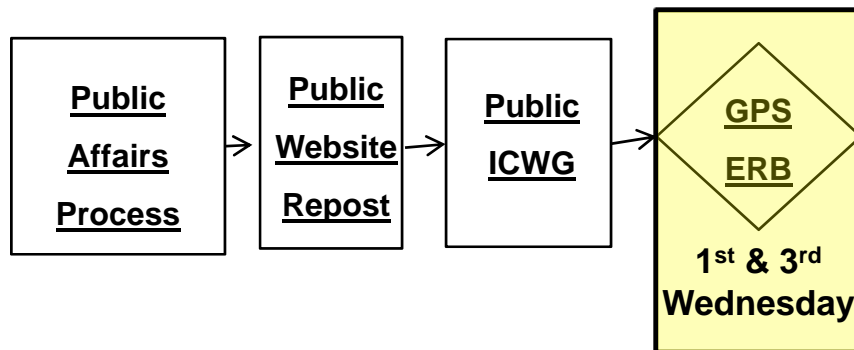

Membership:

- ERB Manager: SE&I
- ERB Core Members: Chaired by GPS Engineering and Integration Division (SMC/GPE) Chief Engineer, are Segment IPT Chief Engineers, Aerospace, SE&I and GPP
GPK and Information Assurance Manager (IAM) attend as necessary.

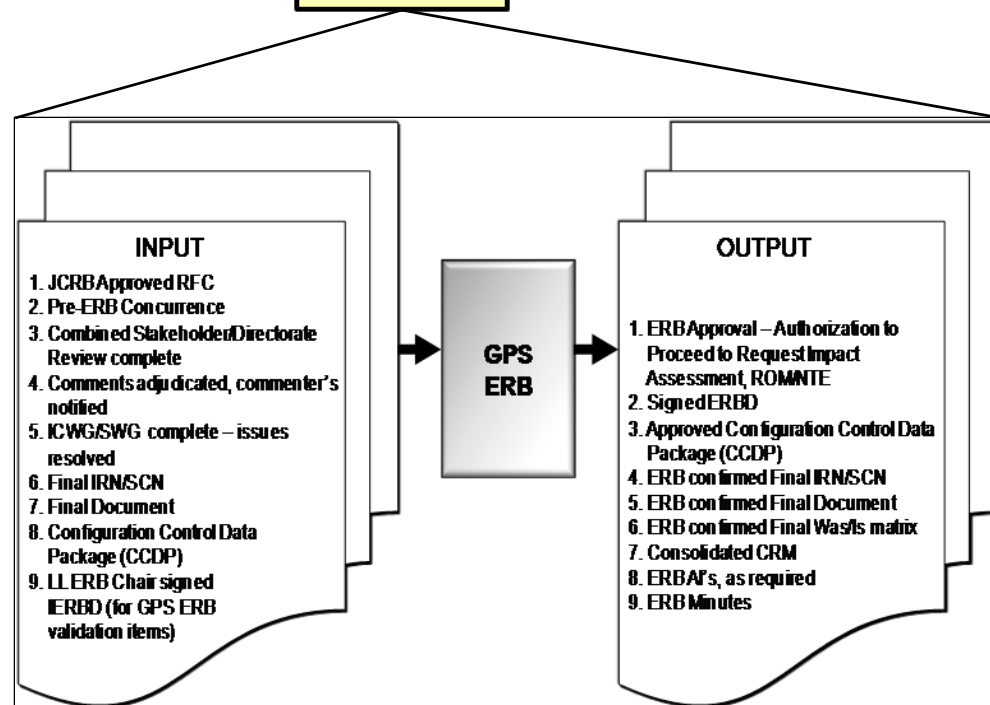

Impact Assessment/ Rough Order of Magnitude (ROM)

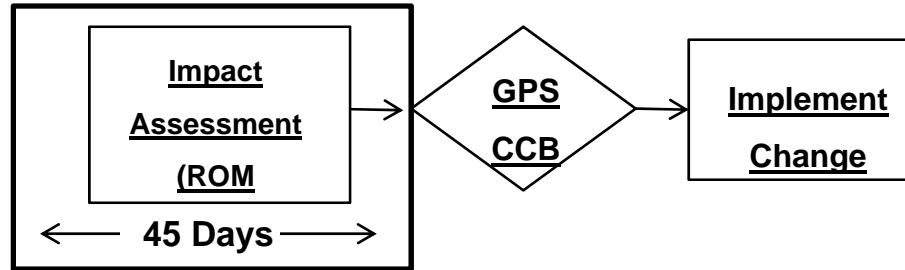

- **Membership:** GPS Contractors, GPS Chief Engineer, SiS RE
- **Impact Assessment/ROM-NTE:**
 - To provide the contractor the opportunity to formally identify contractual issues created by the proposed change (technical, scope/schedule creep) and to provide cost estimation as necessary.
- **PCO for each contract/program affected determines if an impact assessment/ROM-NTE is required.**
- **If required, ROM must be received prior to CCB.**

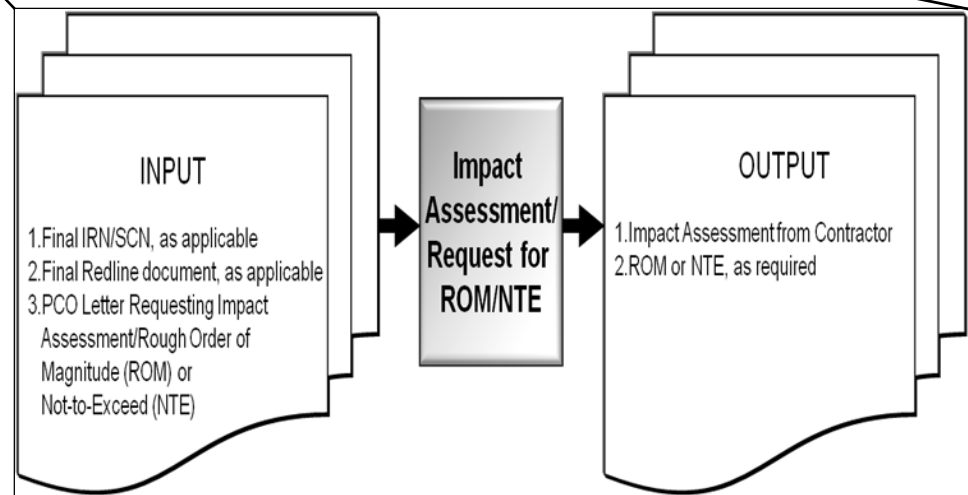

Configuration Control Board (CCB)



- **Membership:**
 - CCB Manager: SE&I
 - CCB Core Members: Segment IPTs AFSPC/A5P, AFSPC, Aerospace, GPP, GPK and IAM
- GPS CCB reviews the benefits, impacts and risks associated with a proposed change, with primary focus on the programmatic aspects.
- Verify technical issues have been addressed/resolved, cost impacts understood and funding is available and that schedule is maintained.

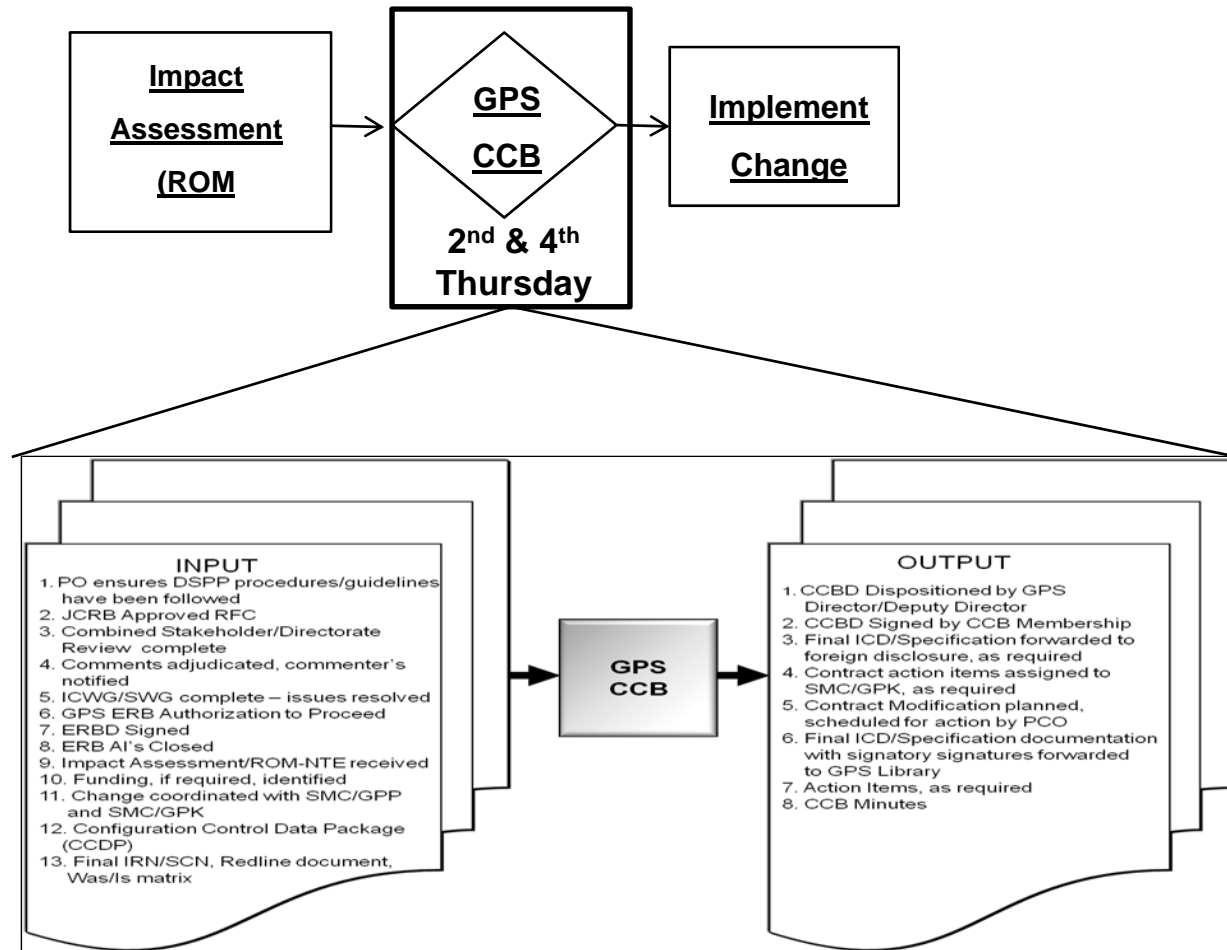

Implement Change

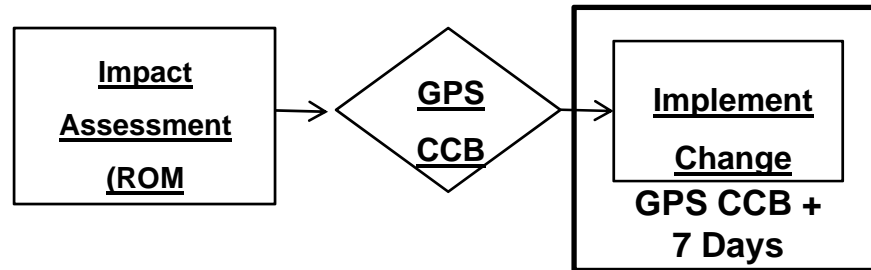

- **Membership:**
- **Upon completion of the previous three phases and receipt of authorization to proceed from the GPS ERB and CCB, or LL CCB, changes may be implemented.**
- **Upon CCB approval, the contractor is formally notified of the results via PCOL / contract modification with attached documentation.**

