

CHANGE NOTICE

Affected Document:

IS-GPS-200 Rev L

IRN/SCN Number

IRN-IS-200L-002

Date:

30-SEP-2020

Authority:

RFC-00413

Proposed Change Notice

PCN-IS-200L_RFC413

Date:

15-APR-2020

CLASSIFIED BY: N/A
DECLASSIFY ON: N/A**Document Title:** NAVSTAR GPS Space Segment/Navigation User Interface**RFC Title:** Integrity Support Message**Reason For Change (Driver):**

1. Navigation integrity for Global Navigation Satellite Systems (GNSS) including GPS has, to date, been codified in performance standard(s) documentation. The implication is that receiver manufacturers must extract information manually and encode it into GNSS receivers. This has two negative effects: 1) operational receivers cannot be modified without a maintenance cycle when updated standards are released; 2) for other-than-GPS systems, receiver manufacturer reliance on documentation produced by foreign entities.
2. Affected documents: IS-GPS-200, IS-GPS-705, IS-GPS-800, ICD-GPS-801, IS-GPS-901, and SS-CS-800

Description of Change:

Define an Integrity Support Message (ISM) that contains pertinent integrity information about GNSS constellations that are compatible with GPS and broadcast the ISM via CNAV (L2C & L5), CNAV-2 (L1C). These messages allow the user to perform Advanced Receiver Autonomous Integrity Monitoring (ARAIM).

Define a pass-through element in ICD-GPS-801 and IS-GPS-901 so that the ISM can be broadcasted from CS to SV.

Authored By: RE: Anthony Flores**Checked By: RE: Albert Hayden****AUTHORIZED SIGNATURES****REPRESENTING****DATE**PNT Capability Area Integration, Portfolio Architect Space
and Missile Systems Center - LAAFB**DISTRIBUTION STATEMENT A. Approved for public release; distribution is unlimited**

THIS DOCUMENT SPECIFIES TECHNICAL REQUIREMENTS AND NOTHING HEREIN CONTAINED SHALL BE DEEMED TO ALTER THE TERMS OF ANY CONTRACT OR PURCHASE ORDER BETWEEN ALL PARTIES AFFECTED.

Interface Control Contractor:
SAIC (GPS SE&I)200 N. Pacific Coast Highway, Suite 1800
El Segundo, CA 90245

CODE IDENT 66RP1

IS200-1488 :

Section Number :

6.1.0-1

WAS :

AI	-	Availability Indicator
AODO	-	Age of Data Offset
A-S	-	Anti-Spoofing
BPSK	-	Bi-Phase Shift Key
CDC	-	Clock Differential Correction
CEI	-	Clock, Ephemeris, Integrity
CNAV	-	Civil Navigation
cps	-	cycles per second
CRC	-	Cyclic Redundancy Check
CS	-	Control Segment
DC	-	Differential Correction
dBc	-	Power ratio of a signal to a (unmodulated) carrier signal, expressed in decibels
dBi	-	Decibel with respect to isotropic antenna
dBW	-	Decibel with respect to 1 W
DN	-	Day Number
EAROM	-	Electrically Alterable Read-Only Memory
ECEF	-	Earth-Centered, Earth-Fixed
ECI	-	Earth-Centered, Inertial
EDC	-	Ephemeris Differential Correction
EOE	-	Edge-of-Earth
EOL	-	End of Life
ERD	-	Estimated Range Deviation
FEC	-	Forward Error Correction

GGTO	-	GPS/GNSS Time Offset
GNSS	-	Global Navigation Satellite System
GPS	-	Global Positioning System
GPSW	-	Global Positioning System Wing
HOW	-	Hand-Over Word
ICC	-	Interface Control Contractor
ID	-	Identification
IERS	-	International Earth Rotation and Reference Systems Service
IODC	-	Issue of Data, Clock
IODE	-	Issue of Data, Ephemeris
IRM	-	IERS Reference Meridian
IRP	-	IERS Reference Pole
IS	-	Interface Specification
ISC	-	Inter-Signal Correction
LNAV	-	Legacy Navigation
LSB	-	Least Significant Bit
LSF	-	Leap Seconds Future
L2C	-	L2 Civil Signal
L2 CL	-	L2 Civil-Long Code
L2 CM	-	L2 Civil-Moderate Code
MCS	-	Master Control Station
MSB	-	Most Significant Bit
NAV	-	Navigation
NDUS	-	NUDET Detection User Segment
NMCT	-	Navigation Message Correction Table
NSC	-	Non-Standard C/A-Code
NSCL	-	Non-Standard L2 CL-Code
NSCM	-	Non-Standard L2 CM-Code

NSY	-	Non-Standard Y-Code
OBCP	-	On-Board Computer Program
OCS	-	Operational Control System
PPS	-	Precise Positioning Service
PRN	-	Pseudo-Random Noise
RF	-	Radio Frequency
RMS	-	Root Mean Square
SA	-	Selective Availability
SEP	-	Spherical Error Probable
SPS	-	Standard Positioning Service
sps	-	symbols per second
SS	-	Space Segment
SSV	-	Space Service Volume
SV	-	Space Vehicle
SVN	-	Space Vehicle Number
TBD	-	To Be Determined
TBS	-	To Be Supplied
TLM	-	Telemetry
TOW	-	Time Of Week
UE	-	User Equipment
URA	-	User Range Accuracy
URE	-	User Range Error
US	-	User Segment
USNO	-	U.S. Naval Observatory
UTC	-	Coordinated Universal Time
WGS 84	-	World Geodetic System 1984
WN	-	Data Sequence Propagation Week Number
WN _e	-	Extended Week Number

Redlines :

AI	-	Availability Indicator
AODO	-	Age of Data Offset
ARAIM	-	Advanced Receiver Autonomous Integrity Monitoring
A-S	-	Anti-Spoofing
BPSK	-	Bi-Phase Shift Key
CDC	-	Clock Differential Correction
CEI	-	Clock, Ephemeris, Integrity
CNAV	-	Civil Navigation
cps	-	cycles per second
CRC	-	Cyclic Redundancy Check
CS	-	Control Segment
DC	-	Differential Correction
dBc	-	Power ratio of a signal to a (unmodulated) carrier signal, expressed in decibels
dB _i	-	Decibel with respect to isotropic antenna
dBW	-	Decibel with respect to 1 W
DN	-	Day Number
EAROM	-	Electrically Alterable Read-Only Memory
ECEF	-	Earth-Centered, Earth-Fixed
ECI	-	Earth-Centered, Inertial
EDC	-	Ephemeris Differential Correction
EOE	-	Edge-of-Earth
EOL	-	End of Life
ERD	-	Estimated Range Deviation
FEC	-	Forward Error Correction
GGTO	-	GPS/GNSS Time Offset

GNSS	-	Global Navigation Satellite System
GPS	-	Global Positioning System
GPSW	-	Global Positioning System Wing
HOW	-	Hand-Over Word
ICC	-	Interface Control Contractor
ID	-	Identification
IERS	-	International Earth Rotation and Reference Systems Service
IODC	-	Issue of Data, Clock
IODE	-	Issue of Data, Ephemeris
IRM	-	IERS Reference Meridian
IRP	-	IERS Reference Pole
IS	-	Interface Specification
ISC	-	Inter-Signal Correction
ISM	=	Integrity Support Message
LNAV	-	Legacy Navigation
LSB	-	Least Significant Bit
LSF	-	Leap Seconds Future
L2C	-	L2 Civil Signal
L2 CL	-	L2 Civil-Long Code
L2 CM	-	L2 Civil-Moderate Code
MCS	-	Master Control Station
MSB	-	Most Significant Bit
MSO	=	Military Standard Order
NAV	-	Navigation
NDUS	-	NUDET Detection User Segment
NMCT	-	Navigation Message Correction Table
NSC	-	Non-Standard C/A-Code
NSCL	-	Non-Standard L2 CL-Code

NSCM	-	Non-Standard L2 CM-Code
NSY	-	Non-Standard Y-Code
OBCP	-	On-Board Computer Program
OCS	-	Operational Control System
PPS	-	Precise Positioning Service
PRN	-	Pseudo-Random Noise
RAIM	=	Receiver Autonomous Integrity Monitoring
RF	-	Radio Frequency
RMS	-	Root Mean Square
SA	-	Selective Availability
SBAS	=	Satellite-Based Augmentation System
SEP	-	Spherical Error Probable
SPS	-	Standard Positioning Service
sps	-	symbols per second
SS	-	Space Segment
SSV	-	Space Service Volume
SV	-	Space Vehicle
SVN	-	Space Vehicle Number
TBD	-	To Be Determined
TBS	-	To Be Supplied
TLM	-	Telemetry
TSO	=	Technical Standard Order
TOW	-	Time Of Week
UE	-	User Equipment
URA	-	User Range Accuracy
URE	-	User Range Error
US	-	User Segment
USNO	-	U.S. Naval Observatory

UTC	-	Coordinated Universal Time
WGS 84	-	World Geodetic System 1984
WN	-	Data Sequence Propagation Week Number
WN _e	-	Extended Week Number

IS :

AI	-	Availability Indicator
AODO	-	Age of Data Offset
ARAIM	-	Advanced Receiver Autonomous Integrity Monitoring
A-S	-	Anti-Spoofing
BPSK	-	Bi-Phase Shift Key
CDC	-	Clock Differential Correction
CEI	-	Clock, Ephemeris, Integrity
CNAV	-	Civil Navigation
cps	-	cycles per second
CRC	-	Cyclic Redundancy Check
CS	-	Control Segment
DC	-	Differential Correction
dBc	-	Power ratio of a signal to a (unmodulated) carrier signal, expressed in decibels
dB _i	-	Decibel with respect to isotropic antenna
dBW	-	Decibel with respect to 1 W
DN	-	Day Number
EAROM	-	Electrically Alterable Read-Only Memory
ECEF	-	Earth-Centered, Earth-Fixed
ECI	-	Earth-Centered, Inertial
EDC	-	Ephemeris Differential Correction
EOE	-	Edge-of-Earth

EOL	-	End of Life
ERD	-	Estimated Range Deviation
FEC	-	Forward Error Correction
GGTO	-	GPS/GNSS Time Offset
GNSS	-	Global Navigation Satellite System
GPS	-	Global Positioning System
GPSW	-	Global Positioning System Wing
HOW	-	Hand-Over Word
ICC	-	Interface Control Contractor
ID	-	Identification
IERS	-	International Earth Rotation and Reference Systems Service
IODC	-	Issue of Data, Clock
IODE	-	Issue of Data, Ephemeris
IRM	-	IERS Reference Meridian
IRP	-	IERS Reference Pole
IS	-	Interface Specification
ISC	-	Inter-Signal Correction
ISM	-	Integrity Support Message
LNAV	-	Legacy Navigation
LSB	-	Least Significant Bit
LSF	-	Leap Seconds Future
L2C	-	L2 Civil Signal
L2 CL	-	L2 Civil-Long Code
L2 CM	-	L2 Civil-Moderate Code
MCS	-	Master Control Station
MSB	-	Most Significant Bit
MSO	-	Military Standard Order
NAV	-	Navigation

NDUS	-	NUDET Detection User Segment
NMCT	-	Navigation Message Correction Table
NSC	-	Non-Standard C/A-Code
NSCL	-	Non-Standard L2 CL-Code
NSCM	-	Non-Standard L2 CM-Code
NSY	-	Non-Standard Y-Code
OBCP	-	On-Board Computer Program
OCS	-	Operational Control System
PPS	-	Precise Positioning Service
PRN	-	Pseudo-Random Noise
RAIM	-	Receiver Autonomous Integrity Monitoring
RF	-	Radio Frequency
RMS	-	Root Mean Square
SA	-	Selective Availability
SBAS	-	Satellite-Based Augmentation System
SEP	-	Spherical Error Probable
SPS	-	Standard Positioning Service
sps	-	symbols per second
SS	-	Space Segment
SSV	-	Space Service Volume
SV	-	Space Vehicle
SVN	-	Space Vehicle Number
TBD	-	To Be Determined
TBS	-	To Be Supplied
TLM	-	Telemetry
TSO	-	Technical Standard Order
TOW	-	Time Of Week
UE	-	User Equipment

URA	-	User Range Accuracy
URE	-	User Range Error
US	-	User Segment
USNO	-	U.S. Naval Observatory
UTC	-	Coordinated Universal Time
WGS 84	-	World Geodetic System 1984
WN	-	Data Sequence Propagation Week Number
WN _e	-	Extended Week Number

IS200-513 :

Section Number :

30.3.2.0-1

WAS :

As shown in Figures 30-1 through 30-14, the CNAV message structure utilizes a basic format of twelve-second 300-bit long messages. Each message contains a Cyclic Redundancy Check (CRC) parity block consisting of 24 bits covering the entire twelve-second message (300 bits) (reference Section 30.3.5). Message Type 0 (zero) is defined to be the default message.

Redlines :

As shown in Figures 30-1 through ~~30-14~~[30-14a](#), the CNAV message structure utilizes a basic format of twelve-second 300-bit long messages. Each message contains a Cyclic Redundancy Check (CRC) parity block consisting of 24 bits covering the entire twelve-second message (300 bits) (reference Section 30.3.5). Message Type 0 (zero) is defined to be the default message

IS :

As shown in Figures 30-1 through 30-14a, the CNAV message structure utilizes a basic format of twelve-second 300-bit long messages. Each message contains a Cyclic Redundancy Check (CRC) parity block consisting of 24 bits covering the entire twelve-second message (300 bits) (reference Section 30.3.5). Message Type 0 (zero) is defined to be the default message.

IS200-1808 :

Insertion after object IS200-1608

Figure 30-14. Message Type 15 - Text

Section Number :

30.3.3.0-30

WAS :

<INSERTED OBJECT>

Redlines :

Object Type : [Figure](#)

IS :

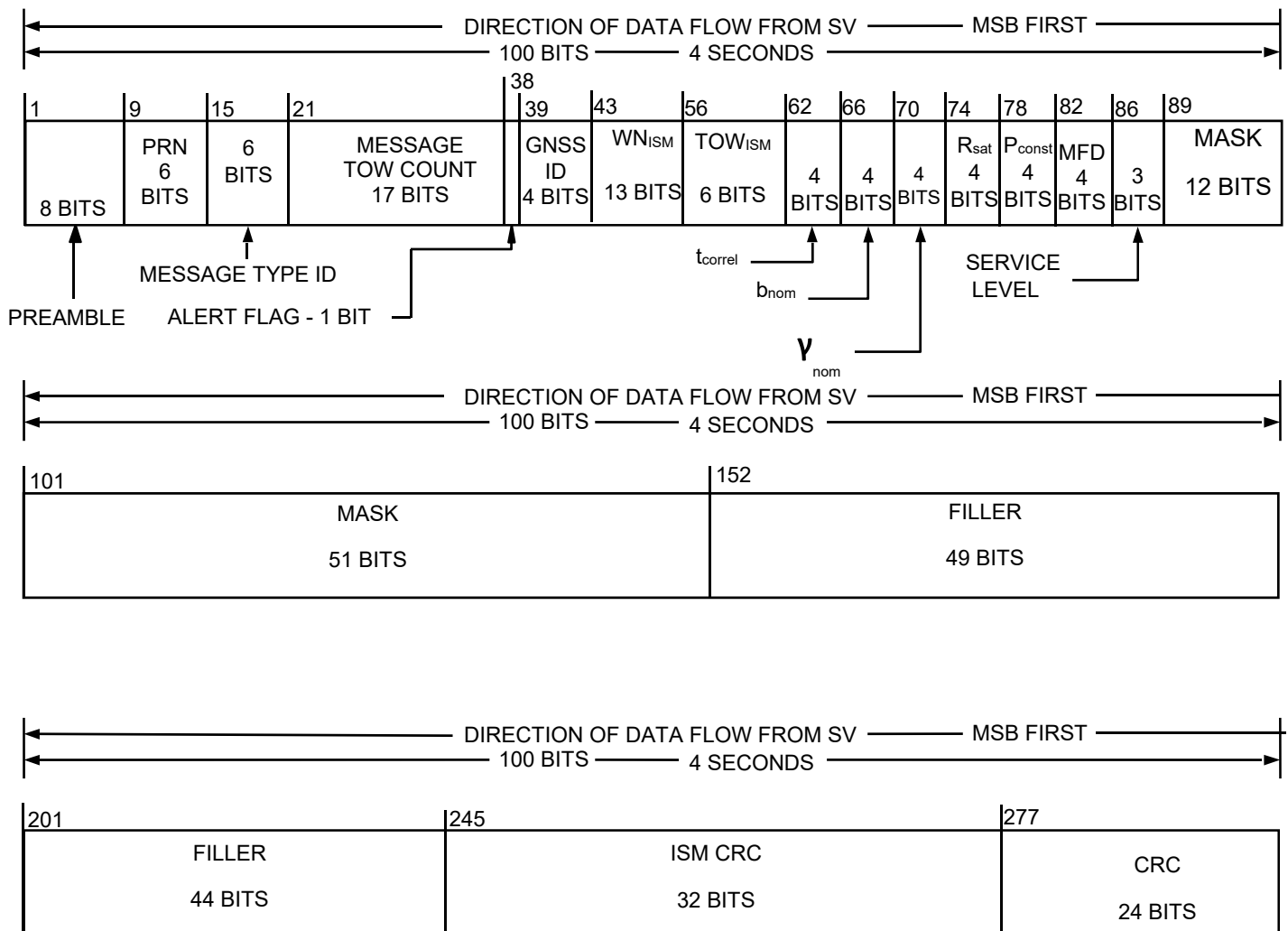

* MESSAGE TOW COUNT = 17 MSBs OF ACTUAL TOW COUNT AT START OF NEXT 12-SECOND MESSAGE

Object Type : Figure

IS200-1809 :

Insertion after object IS200-1808

Section Number :

30.3.3.0-31

WAS :

<INSERTED OBJECT>

Redlines :

[Figure 30-14a. Message Type 40 - Integrity Support Message](#)

IS :

Figure 30-14a. Message Type 40 - Integrity Support Message

IS200-1763 :

Insertion after object IS200-664 (or Sec 30.3.3.9)

30.3.3.9 Message Types 36 and 15 Text Messages.

Text messages are provided either in Message Type 36, Figure 30-9, or type 15, Figure 30-14. The specific contents of text message will be at the discretion of the Operating Command.

Message Type 36 can accommodate the transmission of 18 eight-bit ASCII characters.

Message Type 15 can accommodate the transmission of 29 eight-bit ASCII characters.

The requisite bits shall occupy bits 39 through 274 of Message Type 15 and bits 128 through 275 of Message Type 36.

The eight-bit ASCII characters shall be limited to the set described in paragraph 20.3.3.5.1.8.

Section Number :

30.3.3.10

WAS :

<INSERTED OBJECT>

Redlines :

Object Heading : [Message Type 40 Integrity Support Message \(ISM\)](#)

Object Type : [Header](#)

IS :

Object Heading : **Message Type 40 Integrity Support Message (ISM)**

Object Type : Header

IS200-1764 :

Insertion below object IS200-1763

Section Number :

30.3.3.10.0-1

WAS :

<INSERTED OBJECT>

Redlines :

[Figure 30-14a contains the structure of Message Type 40, Integrity Support Message \(ISM\). The contents of Message Type 40 are defined below, followed by material pertinent to the use of the ISM data. Users who implement Advanced Receiver Autonomous Integrity Monitoring \(ARAIM\) may use these parameters for the ARAIM algorithm as referenced in future TSO and MSO.](#)

IS :

Figure 30-14a contains the structure of Message Type 40, Integrity Support Message (ISM). The contents of Message Type 40 are defined below, followed by material pertinent to the use of the ISM data. Users who implement Advanced Receiver Autonomous Integrity Monitoring (ARAIM) may use these parameters for the ARAIM algorithm as referenced in future TSO and MSO.

IS200-1765 :

Insertion after object IS200-1764

Section Number :

30.3.3.10.1

WAS :

<INSERTED OBJECT>

Redlines :

Object Heading : [ISM Parameter Content](#)

Object Type : [Header](#)

IS :

Object Heading : **ISM Parameter Content**

Object Type : Header

IS200-1766 :

Insertion below object IS200-1765

Section Number :

30.3.3.10.1.0-1

WAS :

<INSERTED OBJECT>

Redlines :

[Message Type 40 shall contain the parameters related to GNSS constellation and satellite integrity parameters used for ARAIM algorithms.](#)

IS :

Message Type 40 shall contain the parameters related to GNSS constellation and satellite integrity parameters used for ARAIM algorithms.

IS200-1767 :

Insertion after object IS200-1766

Section Number :

30.3.3.10.1.0-2

WAS :

<INSERTED OBJECT>

Redlines :

[The bit lengths, scale factors, ranges, and units of these parameters are given in Table 30-X1a.](#)

IS :

The bit lengths, scale factors, ranges, and units of these parameters are given in Table 30-X1a.

IS200-1768 :

Insertion after object IS200-1767

Section Number :

30.3.3.10.1.0-3

WAS :

<INSERTED OBJECT>

Redlines :

[The CS shall upload the current ISM parameters, when necessary, to the SVs](#)

IS :

The CS shall upload the current ISM parameters, when necessary, to the SVs

IS200-1990 :

Insertion after object IS200-1768

Section Number :

30.3.3.10.1.0-4

WAS :

<INSERTED OBJECT>

Redlines :

[Users should use the ISM parameters with the most recent \$WN_{ISM}\$ and \$TOW_{ISM}\$ time stamp. All time stamps should be in the past.](#)

IS :

Users should use the ISM parameters with the most recent WN_{ISM} and TOW_{ISM} time stamp. All time stamps should be in the past.

IS200-1772 :

Insertion after object IS200-1990

Section Number :

30.3.3.10.1.0-7

WAS :

<INSERTED OBJECT>

Redlines :

[Table 30-XIa – ISM Parameters](#)

IS :

Table 30-XIa – ISM Parameters

IS200-1770 :

Insertion after object IS200-1772

Section Number :

30.3.3.10.1.0-8

WAS :

<INSERTED OBJECT>

Redlines :*Object Type :* [Table](#)**IS :**

Parameter	No. of Bits**	Scale Factor (LSB)	Valid Range***	Units
GNSS ID	4			
WN _{ISM}	13	1		weeks
TOW _{ISM}	6	4	0 to 164	hours
t _{correl}	4		0 to 12	hours
b _{nom}	4		0 to 2	meters
γ _{nom}	4		0 to 2	
R _{sat}	4		1x10 ⁻³ to 3.16x10 ⁻¹⁰	/hours
P _{const}	4		1x10 ⁻³ to 3.16 x10 ⁻¹⁰	
MFD	4		0.25 to 24	hours
Service Level*	3			
Mask****	63			

* See Table 30-XIb for Service Level Descriptions
** See Figure 30-14a for complete bit allocation in Message Type 40
*** Unless otherwise indicated in this column, valid range is the maximum range attainable with indicated bit allocation and scale factor
**** See Table 30-XIb for Mask bit mapping

Object Type : Table

IS200-1775 :

Insertion after object IS200-1770

Section Number :

30.3.3.10.1.1

WAS :

<INSERTED OBJECT>

Redlines :

Object Heading : [GNSS Constellation ID](#)

Object Type : [Header](#)

IS :

Object Heading : **GNSS Constellation ID**

Object Type : Header

IS200-1776 :

Insertion below object IS200-1775

Section Number :

30.3.3.10.1.1.0-1

WAS :

<INSERTED OBJECT>

Redlines :

[Bits 39 through 42 of Message Type 40 shall identify the GNSS service to which the associated ISM parameters apply.](#)

IS :

Bits 39 through 42 of Message Type 40 shall identify the GNSS service to which the associated ISM parameters apply.

IS200-1777 :

Insertion after object IS200-1776

Section Number :

30.3.3.10.1.1.0-2

WAS :

<INSERTED OBJECT>

Redlines :

[The four bits are defined as follows:](#)

[0000 = No Data Available](#)

[0001 = Galileo](#)

[0010 = GLONASS](#)

[0011 = BeiDou](#)

[0100 = GPS](#)

[0101 = SBAS](#)

[0110 = QZSS](#)

[0111 = IRNSS](#)

[1000 through 1111 = Reserved for other systems](#)

IS :

The four bits are defined as follows:

0000 = No Data Available

0001 = Galileo

0010 = GLONASS

0011 = BeiDou

0100 = GPS

0101 = SBAS

0110 = QZSS

0111 = IRNSS

1000 through 1111 = Reserved for other systems

IS200-1814 :

Insertion after object IS200-1777

WAS :

<INSERTED OBJECT>

Section Number :

30.3.3.10.1.1.0-3

Redlines :

[If users see four bits of '0000', users will ignore the entire ISM.](#)

IS :

If users see four bits of '0000', users will ignore the entire ISM.

IS200-1778 :

Insertion after object IS200-1775

Section Number :

30.3.3.10.1.2

WAS :

<INSERTED OBJECT>

Redlines :

Object Heading : [ISM Effectivity Time Stamp Week Number](#)

IS :

Object Heading : **ISM Effectivity Time Stamp Week Number**

IS200-1779 :

Insertion below object IS200-1778

Section Number :

30.3.3.10.1.2.0-1

WAS :

<INSERTED OBJECT>

Redlines :

[Bits 43 through 55 of Message Type 40 shall provide the ISM Week Number \(WN_{ISM}\) applicable to the start of the time of validity for a given ISM data issue.](#)

IS :

Bits 43 through 55 of Message Type 40 shall provide the ISM Week Number (WN_{ISM}) applicable to the start of the time of validity for a given ISM data issue.

IS200-1780 :

Insertion after object IS200-1779

Section Number :

30.3.3.10.1.2.0-2

WAS :

<INSERTED OBJECT>

Redlines :

[This parameter describes the time stamp, in terms of weeks, for the ISM parameters.](#)

IS :

This parameter describes the time stamp, in terms of weeks, for the ISM parameters.

IS200-1781 :

Insertion after object IS200-1778

Section Number :

30.3.3.10.1.3

WAS :

<INSERTED OBJECT>

Redlines :

Object Heading : [ISM Effectivity Time Stamp Time of Week](#)

IS :

Object Heading : **ISM Effectivity Time Stamp Time of Week**

IS200-1782 :

Insertion below object IS200-1781

Section Number :

30.3.3.10.1.3.0-1

WAS :

<INSERTED OBJECT>

Redlines :

[Bits 56 through 61 of Message Type 40 shall provide the ISM Time of Week \(TOW_{ISM}\) applicable to the start of the time of validity for a given ISM data issue.](#)

IS :

Bits 56 through 61 of Message Type 40 shall provide the ISM Time of Week (TOW_{ISM}) applicable to the start of the time of validity for a given ISM data issue.

IS200-1783 :

Insertion after object IS200-1782

Section Number :

30.3.3.10.1.3.0-2

WAS :

<INSERTED OBJECT>

Redlines :

[This parameter describes the time stamp, in terms of hours, for the ISM parameters.](#)

IS :

This parameter describes the time stamp, in terms of hours, for the ISM parameters.

IS200-1790 :

Insertion after object IS200-1781

Section Number :

30.3.3.10.1.4

WAS :

<INSERTED OBJECT>

Redlines :

Object Heading : [Correlation Time Constant](#)

IS :

Object Heading : **Correlation Time Constant**

IS200-1791 :

Insertion below object IS200-1790

Section Number :

30.3.3.10.1.4.0-1

WAS :

<INSERTED OBJECT>

Redlines :

[Bits 62 through 65 of Message Type 40 shall provide the assumed Correlation Time Constant \(\$t_{\text{correl}}\$ \) value for the ARAIM at the current time for the associated GNSS constellation.](#)

IS :

Bits 62 through 65 of Message Type 40 shall provide the assumed Correlation Time Constant (t_{correl}) value for the ARAIM at the current time for the associated GNSS constellation.

IS200-1792 :

Insertion after object IS200-1791

Section Number :

30.3.3.10.1.4.0-2

WAS :

<INSERTED OBJECT>

Redlines :

The four bits are defined as follows:

0000 = 0.25 hours

0001 = 0.33 hours

0010 = 0.50 hours

0011 = 0.67 hours

0100 = 0.83 hours

0101 = 1.00 hour

0110 = 1.17 hours

0111 = 1.33 hours

1000 = 1.50 hours

1001 = 2.10 hours

1010 = 3.00 hours

1011 = 4.20 hours

1100 = 6.00 hours

1101 = 8.50 hours

1110 = 12.00 hours

1111 = RESERVED

IS :

The four bits are defined as follows:

0000 = 0.25 hours

0001 = 0.33 hours

0010 = 0.50 hours

0011 = 0.67 hours

0100 = 0.83 hours

0101 = 1.00 hour

0110 = 1.17 hours

0111 = 1.33 hours

1000 = 1.50 hours

1001 = 2.10 hours

1010 = 3.00 hours

1011 = 4.20 hours

1100 = 6.00 hours

1101 = 8.50 hours

1110 = 12.00 hours

1111 = RESERVED

IS200-1802 :

Insertion after object IS200-1790

Section Number :

30.3.3.10.1.5

WAS :

<INSERTED OBJECT>

Redlines :

Object Heading : [Additive Term for Nominal Pseudorange Error Bias](#)

IS :

Object Heading : **Additive Term for Nominal Pseudorange Error Bias**

IS200-1803 :

Insertion below object IS200-1802

Section Number :

30.3.3.10.1.5.0-1

WAS :

<INSERTED OBJECT>

Redlines :

[Bits 66 through 69 of Message Type 40 shall provide the assumed Additive Term \(\$b_{nom}\$ \) value for ARAIM at the current time for the associated GNSS constellation.](#)

IS :

Bits 66 through 69 of Message Type 40 shall provide the assumed Additive Term (b_{nom}) value for ARAIM at the current time for the associated GNSS constellation.

IS200-1804 :

Insertion after object IS200-1803

Section Number :

30.3.3.10.1.5.0-2

WAS :

<INSERTED OBJECT>

Redlines :

[The four bits are defined as follows:](#)

[0000 = 0.00 meters](#)

[0001 = 0.13 meters](#)

[0010 = 0.25 meters](#)

[0011 = 0.38 meters](#)

[0100 = 0.50 meters](#)

[0101 = 0.63 meters](#)

[0110 = 0.75 meters](#)

[0111 = 0.88 meters](#)

[1000 = 1.00 meter](#)

[1001 = 1.13 meters](#)

[1010 = 1.25 meters](#)

[1011 = 1.38 meters](#)

[1100 = 1.50 meters](#)

[1101 = 1.63 meters](#)

[1110 = 1.75 meters](#)

[1111 = 2.00 meters](#)

IS :

The four bits are defined as follows:

0000 = 0.00 meters

0001 = 0.13 meters

0010 = 0.25 meters

0011 = 0.38 meters

0100 = 0.50 meters

0101 = 0.63 meters

0110 = 0.75 meters

0111 = 0.88 meters

1000 = 1.00 meter

1001 = 1.13 meters

1010 = 1.25 meters

1011 = 1.38 meters

1100 = 1.50 meters

1101 = 1.63 meters

1110 = 1.75 meters

1111 = 2.00 meters

IS200-1805 :

Insertion after object IS200-1802

Section Number :

30.3.3.10.1.6

WAS :

<INSERTED OBJECT>

Redlines :

Object Heading : [Scalar Term for Nominal Pseudorange Error Bias](#)

IS :

Object Heading : **Scalar Term for Nominal Pseudorange Error Bias**

IS200-1806 :

Insertion below object IS200-1805

Section Number :

30.3.3.10.1.6.0-1

WAS :

<INSERTED OBJECT>

Redlines :

[Bits 70 through 73 of Message Type 40 shall provide the assumed Scalar Term \(\$\gamma_{nom}\$ \)value for ARAIM at the current time for the associated GNSS constellation.](#)

IS :

Bits 70 through 73 of Message Type 40 shall provide the assumed Scalar Term (γ_{nom})value for ARAIM at the current time for the associated GNSS constellation.

IS200-1807 :

Insertion after object IS200-1806

Section Number :

30.3.3.10.1.6.0-2

WAS :

<INSERTED OBJECT>

Redlines :

The four bits are defined as follows:

0000 = 0.00

0001 = 0.13

0010 = 0.25

0011 = 0.38

0100 = 0.50

0101 = 0.63

0110 = 0.75

0111 = 0.88

1000 = 1.00

1001 = 1.13

1010 = 1.25

1011 = 1.38

1100 = 1.50

1101 = 1.63

1110 = 1.75

1111 = 2.00

IS :

The four bits are defined as follows:

0000 = 0.00

0001 = 0.13

0010 = 0.25

0011 = 0.38

0100 = 0.50

0101 = 0.63

0110 = 0.75

0111 = 0.88

1000 = 1.00

1001 = 1.13

1010 = 1.25

1011 = 1.38

1100 = 1.50

1101 = 1.63

1110 = 1.75

1111 = 2.00

IS200-1796 :

Insertion after object IS200-1805

Section Number :

30.3.3.10.1.7

WAS :

<INSERTED OBJECT>

Redlines :

Object Heading : [Satellite Fault Probability](#)

IS :

Object Heading : **Satellite Fault Probability**

IS200-1797 :

Insertion below object IS200-1796

Section Number :

30.3.3.10.1.7.0-1

WAS :

<INSERTED OBJECT>

Redlines :

Bits 74 through 77 of Message Type 40 shall provide the assumed Satellite Fault Probability (R_{sat}) value for ARAIM at the current time for the associated GNSS constellation.

IS :

Bits 74 through 77 of Message Type 40 shall provide the assumed Satellite Fault Probability (R_{sat}) value for ARAIM at the current time for the associated GNSS constellation.

IS200-1798 :

Insertion after object IS200-1797

Section Number :

30.3.3.10.1.7.0-2

WAS :

<INSERTED OBJECT>

Redlines :

The four bits are defined as follows:

0000 = 3.16×10^{-3} /hours

0001 = 1×10^{-3} /hours

0010 = 3.16×10^{-4} /hours

0011 = 1×10^{-4} /hours

0100 = 3.16×10^{-5} /hours

0101 = 1×10^{-5} /hours

0110 = 3.16×10^{-6} /hours

0111 = 1×10^{-6} /hours

1000 = 3.16×10^{-7} /hours

1001 = 1×10^{-7} /hours

1010 = 3.16×10^{-8} /hours

1011 = 1×10^{-8} /hours

1100 = 3.16×10^{-9} /hours

1101 = 1×10^{-9} /hours

1110 = 3.16×10^{-10} /hours

1111 = RESERVED

IS :

The four bits are defined as follows:

$$0000 = 3.16 \times 10^{-3} / \text{hours}$$

$$0001 = 1 \times 10^{-3} / \text{hours}$$

$$0010 = 3.16 \times 10^{-4} / \text{hours}$$

$$0011 = 1 \times 10^{-4} / \text{hours}$$

$$0100 = 3.16 \times 10^{-5} / \text{hours}$$

$$0101 = 1 \times 10^{-5} / \text{hours}$$

$$0110 = 3.16 \times 10^{-6} / \text{hours}$$

$$0111 = 1 \times 10^{-6} / \text{hours}$$

$$1000 = 3.16 \times 10^{-7} / \text{hours}$$

$$1001 = 1 \times 10^{-7} / \text{hours}$$

$$1010 = 3.16 \times 10^{-8} / \text{hours}$$

$$1011 = 1 \times 10^{-8} / \text{hours}$$

$$1100 = 3.16 \times 10^{-9} / \text{hours}$$

$$1101 = 1 \times 10^{-9} / \text{hours}$$

$$1110 = 3.16 \times 10^{-10} / \text{hours}$$

$$1111 = \text{RESERVED}$$

IS200-1787 :

Insertion after object IS200-1796

Section Number :

30.3.3.10.1.8

WAS :

<INSERTED OBJECT>

Redlines :

Object Heading : [Constellation Fault Probability](#)

IS :

Object Heading : **Constellation Fault Probability**

IS200-1788 :

Insertion below object IS200-1787

Section Number :

30.3.3.10.1.8.0-1

WAS :

<INSERTED OBJECT>

Redlines :

[Bits 78 through 81 of Message Type 40 shall provide the assumed Constellation Fault Probability \(\$P_{\text{const}}\$ \) value for ARAIM at the current time for the associated GNSS constellation.](#)

IS :

Bits 78 through 81 of Message Type 40 shall provide the assumed Constellation Fault Probability (P_{const}) value for ARAIM at the current time for the associated GNSS constellation.

IS200-1789 :

Insertion after object IS200-1788

Section Number :

30.3.3.10.1.8.0-2

WAS :

<INSERTED OBJECT>

Redlines :

The four bits are defined as follows:

0000 = 3.16×10^{-3}

0001 = 1×10^{-3}

0010 = 3.16×10^{-4}

0011 = 1×10^{-4}

0100 = 3.16×10^{-5}

0101 = 1×10^{-5}

0110 = 3.16×10^{-6}

0111 = 1×10^{-6}

1000 = 3.16×10^{-7}

1001 = 1×10^{-7}

1010 = 3.16×10^{-8}

1011 = 1×10^{-8}

1100 = 3.16×10^{-9}

1101 = 1×10^{-9}

1110 = 3.16×10^{-10}

1111 = RESERVED

IS :

The four bits are defined as follows:

$$0000 = 3.16 \times 10^{-3}$$

$$0001 = 1 \times 10^{-3}$$

$$0010 = 3.16 \times 10^{-4}$$

$$0011 = 1 \times 10^{-4}$$

$$0100 = 3.16 \times 10^{-5}$$

$$0101 = 1 \times 10^{-5}$$

$$0110 = 3.16 \times 10^{-6}$$

$$0111 = 1 \times 10^{-6}$$

$$1000 = 3.16 \times 10^{-7}$$

$$1001 = 1 \times 10^{-7}$$

$$1010 = 3.16 \times 10^{-8}$$

$$1011 = 1 \times 10^{-8}$$

$$1100 = 3.16 \times 10^{-9}$$

$$1101 = 1 \times 10^{-9}$$

$$1110 = 3.16 \times 10^{-10}$$

$$1111 = \text{RESERVED}$$

IS200-1799 :

Insertion after object IS200-1787

Section Number :

30.3.3.10.1.9

WAS :

<INSERTED OBJECT>

Redlines :

Object Heading : [Mean Fault Duration](#)

IS :

Object Heading : **Mean Fault Duration**

IS200-1800 :

Insertion below object IS200-1799

Section Number :

30.3.3.10.1.9.0-1

WAS :

<INSERTED OBJECT>

Redlines :

[Bits 82 through 85 of Message Type 40 shall provide the assumed Mean Fault Duration \(MFD\) value for ARAIM at the current time for the associated GNSS constellation.](#)

IS :

Bits 82 through 85 of Message Type 40 shall provide the assumed Mean Fault Duration (MFD) value for ARAIM at the current time for the associated GNSS constellation.

IS200-1801 :

Insertion after object IS200-1800

Section Number :

30.3.3.10.1.9.0-2

WAS :

<INSERTED OBJECT>

Redlines :

[The four bits are defined as follows:](#)

[0000 = 0.25 hours](#)

[0001 = 0.33 hours](#)

[0010 = 0.50 hours](#)

[0011 = 0.67 hours](#)

[0100 = 0.83 hours](#)

[0101 = 1 hour](#)

[0110 = 1.25 hours](#)

[0111 = 1.50 hours](#)

[1000 = 1.75 hours](#)

[1001 = 2 hours](#)

[1010 = 3 hours](#)

[1011 = 4 hours](#)

[1100 = 7 hours](#)

[1101 = 10 hours](#)

[1110 = 17 hours](#)

[1111 = 24 hours](#)

IS :

The four bits are defined as follows:

0000 = 0.25 hours

0001 = 0.33 hours

0010 = 0.50 hours

0011 = 0.67 hours

0100 = 0.83 hours

0101 = 1 hour

0110 = 1.25 hours

0111 = 1.50 hours

1000 = 1.75 hours

1001 = 2 hours

1010 = 3 hours

1011 = 4 hours

1100 = 7 hours

1101 = 10 hours

1110 = 17 hours

1111 = 24 hours

IS200-1784 :

Insertion after object IS200-1799

Section Number :

30.3.3.10.1.10

WAS :

<INSERTED OBJECT>

Redlines :

Object Heading : [Service Level](#)

IS :

Object Heading : **Service Level**

IS200-1785 :

Insertion below object IS200-1784

Section Number :

30.3.3.10.1.10.0-1

WAS :

<INSERTED OBJECT>

Redlines :

[Bits 86 through 88 of Message Type 40 shall provide the Service Level, as described in Table 30-X1b, applicable to a given page of the ISM data issue.](#)

IS :

Bits 86 through 88 of Message Type 40 shall provide the Service Level, as described in Table 30-X1b, applicable to a given page of the ISM data issue.

IS200-1786 :

Insertion after object IS200-1785

Section Number :

30.3.3.10.1.10.0-2

WAS :

<INSERTED OBJECT>

Redlines :

[Three bits are allocated to the four identified service levels as follows:](#)

[000 = Level 1](#)

[001 = Level 2](#)

[010 = Level 3](#)

[011 = Level 4](#)

[100 to 111 = Reserved for future use](#)

IS :

Three bits are allocated to the four identified service levels as follows:

000 = Level 1

001 = Level 2

010 = Level 3

011 = Level 4

100 to 111 = Reserved for future use

IS200-1773 :

Insertion after object IS200-1786

Section Number :

30.3.3.10.1.10.0-3

WAS :

<INSERTED OBJECT>

Redlines :

[Table 30-XIb - Service Level](#)

IS :

Table 30-XIb - Service Level

IS200-1774 :

Insertion after object IS200-1773

Section Number :

30.3.3.10.1.10.0-4

WAS :

<INSERTED OBJECT>

Redlines :

Object Type : [Table](#)

IS :

Service Level	Severity	Description
Level 1	No Data Available	Service Level indicates that users may resort to the Performance Values for integrity solutions instead of this ISM. Users should not use this ISM
Level 2	Non-Safety of Life Use	Service Level indicates that users may only use these parameters for non-safety of life (i.e., uncertified ARAIM) applications.
Level 3	Safety of Life Use (Horizontal)	Service Level indicates that the user should only use these parameters for the applications requiring integrity less than or equivalent to H-ARAIM solutions.
Level 4	Safety of Life Use (Vertical)	Service Level indicates that the user should only use these parameters for the applications requiring integrity less than or equivalent to V-ARAIM solutions.

Object Type : Table

IS200-1793 :

Insertion after object IS200-1784

Section Number :

30.3.3.10.1.11

WAS :

<INSERTED OBJECT>

Redlines :

Object Heading : [Satellite Mask](#)

IS :

Object Heading : **Satellite Mask**

IS200-1794 :

Insertion below object IS200-1793

Section Number :
30.3.3.10.1.11.0-1

WAS :
<INSERTED OBJECT>

Redlines :
[Bits 89 through 151 of Message Type 40 shall provide the PRN inclusion mask. Refer to Table 30-X1c for complete GNSS PRN mapping.](#)

IS :
Bits 89 through 151 of Message Type 40 shall provide the PRN inclusion mask. Refer to Table 30-X1c for complete GNSS PRN mapping.

IS200-1795 :
Insertion after object IS200-1794

Section Number :
30.3.3.10.1.11.0-2

WAS :
<INSERTED OBJECT>

Redlines :
[The applicability of each PRN is indicated by:](#)
[0 = Information in the current ISM does not apply to this PRN](#)
[1 = Information in the current ISM does apply to this PRN](#)

IS :
The applicability of each PRN is indicated by:
0 = Information in the current ISM does not apply to this PRN
1 = Information in the current ISM does apply to this PRN

IS200-1815 :

Insertion after object IS200-1795

Section Number :

30.3.3.10.1.11.0-3

WAS :

<INSERTED OBJECT>

Redlines :[Table 30-XIc PRN Mapping](#)**IS :**

Table 30-XIc PRN Mapping

IS200-1816 :

Insertion after object IS200-1815

Section Number :

30.3.3.10.1.11.0-4

WAS :

<INSERTED OBJECT>

Redlines :

<INSERTED OBJECT>

IS :

Bits	Galileo	GLONASS	BeiDou	GPS	SBAS	QZSS	IRNSS
89	SVID 1	Freq. 1	RCN 1	PRN 1	PRN 120	PRN 183	PRN ID-1
90	SVID 2	Freq. 2	RCN 2	PRN 2	PRN 121	PRN 184	PRN ID-2
91	SVID 3	Freq. 3	RCN 3	PRN 3	PRN 122	PRN 185	PRN ID-3
92	SVID 4	Freq. 4	RCN 4	PRN 4	PRN 123	PRN 186	PRN ID-4
93	SVID 5	Freq. 5	RCN 5	PRN 5	PRN 124	PRN 187	PRN ID-5
94	SVID 6	Freq. 6	RCN 6	PRN 6	PRN 125	PRN 188	PRN ID-6
95	SVID 7	Freq. 7	RCN 7	PRN 7	PRN 126	PRN 189	PRN ID-7
96	SVID 8	Freq. 8	RCN 8	PRN 8	PRN 127	PRN 190	Reserved
97	SVID 9	Freq. 9	RCN 9	PRN 9	PRN 128	PRN 191	Reserved
98	SVID 10	Freq. 10	RCN 10	PRN 10	PRN 129	PRN 192	Reserved
99	SVID 11	Freq. 11	RCN 11	PRN 11	PRN 130	PRN 193	Reserved
100	SVID 12	Freq. 12	RCN 12	PRN 12	PRN 131	PRN 194	Reserved
101	SVID 13	Freq. 13	RCN 13	PRN 13	PRN 132	PRN 195	Reserved
102	SVID 14	Freq. 14	RCN 14	PRN 14	PRN 133	PRN 196	Reserved
103	SVID 15	Freq. 15	RCN 15	PRN 15	PRN 134	PRN 197	Reserved
104	SVID 16	Freq. 16	RCN 16	PRN 16	PRN 135	PRN 198	Reserved
105	SVID 17	Freq. 17	RCN 17	PRN 17	PRN 136	PRN 199	Reserved
106	SVID 18	Freq. 18	RCN 18	PRN 18	PRN 137	PRN 200	Reserved
107	SVID 19	Freq. 19	RCN 19	PRN 19	PRN 138	PRN 201	Reserved
108	SVID 20	Freq. 20	RCN 20	PRN 20	PRN 139	PRN 202	Reserved
109	SVID 21	Freq. 21	RCN 21	PRN 21	PRN 140	Reserved	Reserved
110	SVID 22	Freq. 22	RCN 22	PRN 22	PRN 141	Reserved	Reserved
111	SVID 23	Freq. 23	RCN 23	PRN 23	PRN 142	Reserved	Reserved
112	SVID 24	Freq. 24	RCN 24	PRN 24	PRN 143	Reserved	Reserved
113	SVID 25	Freq. 25	RCN 25	PRN 25	PRN 144	Reserved	Reserved

114	SVID 26	Freq. 26	RCN 26	PRN 26	PRN 145	Reserved	Reserved
115	SVID 27	Freq. 27	RCN 27	PRN 27	PRN 146	Reserved	Reserved
116	SVID 28	Freq. 28	RCN 28	PRN 28	PRN 147	Reserved	Reserved
117	SVID 29	Freq. 29	RCN 29	PRN 29	PRN 148	Reserved	Reserved
118	SVID 30	Freq. 30	RCN 30	PRN 30	PRN 149	Reserved	Reserved
119	SVID 31	Freq. 31	RCN 31	PRN 31	PRN 150	Reserved	Reserved
120	SVID 32	Freq. 32	RCN 32	PRN 32	PRN 151	Reserved	Reserved
121	SVID 33	Reserved	RCN 33	PRN 33	PRN 152	Reserved	Reserved
122	SVID 34	Reserved	RCN 34	PRN 34	PRN 153	Reserved	Reserved
123	SVID 35	Reserved	RCN 35	PRN 35	PRN 154	Reserved	Reserved
124	SVID 36	Reserved	RCN 36	PRN 36	PRN 155	Reserved	Reserved
125	Reserved	Reserved	RCN 37	PRN 37	PRN 156	Reserved	Reserved
126	Reserved	Reserved	Reserved	PRN 38	PRN 157	Reserved	Reserved
127	Reserved	Reserved	Reserved	PRN 39	PRN 158	Reserved	Reserved
128	Reserved	Reserved	Reserved	PRN 40	Reserved	Reserved	Reserved
129	Reserved	Reserved	Reserved	PRN 41	Reserved	Reserved	Reserved
130	Reserved	Reserved	Reserved	PRN 42	Reserved	Reserved	Reserved
131	Reserved	Reserved	Reserved	PRN 43	Reserved	Reserved	Reserved
132	Reserved	Reserved	Reserved	PRN 44	Reserved	Reserved	Reserved
133	Reserved	Reserved	Reserved	PRN 45	Reserved	Reserved	Reserved
134	Reserved	Reserved	Reserved	PRN 46	Reserved	Reserved	Reserved
135	Reserved	Reserved	Reserved	PRN 47	Reserved	Reserved	Reserved
136	Reserved	Reserved	Reserved	PRN 48	Reserved	Reserved	Reserved
137	Reserved	Reserved	Reserved	PRN 49	Reserved	Reserved	Reserved
138	Reserved	Reserved	Reserved	PRN 50	Reserved	Reserved	Reserved
139	Reserved	Reserved	Reserved	PRN 51	Reserved	Reserved	Reserved
140	Reserved	Reserved	Reserved	PRN 52	Reserved	Reserved	Reserved
141	Reserved	Reserved	Reserved	PRN 53	Reserved	Reserved	Reserved
142	Reserved	Reserved	Reserved	PRN 54	Reserved	Reserved	Reserved
143	Reserved	Reserved	Reserved	PRN 55	Reserved	Reserved	Reserved
144	Reserved	Reserved	Reserved	PRN 56	Reserved	Reserved	Reserved
145	Reserved	Reserved	Reserved	PRN 57	Reserved	Reserved	Reserved
146	Reserved	Reserved	Reserved	PRN 58	Reserved	Reserved	Reserved
147	Reserved	Reserved	Reserved	PRN 59	Reserved	Reserved	Reserved
148	Reserved	Reserved	Reserved	PRN 60	Reserved	Reserved	Reserved
149	Reserved	Reserved	Reserved	PRN 61	Reserved	Reserved	Reserved
150	Reserved	Reserved	Reserved	PRN 62	Reserved	Reserved	Reserved
151	Reserved	Reserved	Reserved	PRN 63	Reserved	Reserved	Reserved
SVID = Space Vehicle ID Freq. = Carrier Frequency Number RCN = Ranging Code Number PRN = Pseudorandom Noise Number							

IS200-1817 :

Insertion after object IS200-1793

Section Number :

30.3.3.10.1.12

WAS :

<INSERTED OBJECT>

Redlines :

Object Heading : [Integrity Support Message Cyclic Redundancy Check](#)

IS :

Object Heading : **Integrity Support Message Cyclic Redundancy Check**

IS200-1818 :

Insertion below object IS200-1817

Section Number :

30.3.3.10.1.12.0-1

WAS :

<INSERTED OBJECT>

Redlines :

[Bits 245 through 276 of MT-40 are a 32-bit Cyclic Redundancy Check \(CRC\) specific to the ISM parameters. The ISM CRC will cover only the ISM parameters in Message Type 40, \(Bits 39 to 244\). Refer to DO-246E-Change 1 document for more details on the ISM CRC.](#)

IS :

Bits 245 through 276 of MT-40 are a 32-bit Cyclic Redundancy Check (CRC) specific to the ISM parameters. The ISM CRC will cover only the ISM parameters in Message Type 40, (Bits 39 to 244). Refer to DO-246E-Change 1 document for more details on the ISM CRC.

IS200-670 :

Section Number :

30.3.4.1.0-4

WAS :

Message Data	Message Type Number	Maximum Broadcast Intervals †
Ephemeris	10 & 11	48 sec
Clock	Type 30's	48 sec
ISC, IONO	30*	288 sec
Reduced Almanac	31* or 12	20 min**,****
Midi Almanac	37*	120 min**,****
EOP	32*	30 min****
UTC	33*	288 sec
Diff Correction	34* or 13 & 14	30 min****,****
GGTO	35*	288 sec****
Text	36* or 15	As needed****
<p>* Also contains SV clock correction parameters. ** Complete set of SVs in the constellation. *** When Differential Corrections are available. **** Optional (interval applies if/when broadcast).</p> <p>† The intervals specified are maximum. As such, the broadcast intervals may be shorter than the specified value.</p>		

Redlines :

Message Data	Message Type Number	Maximum Broadcast Intervals †
Ephemeris	10 & 11	48 sec
Clock	Type 30's	48 sec
ISC, IONO	30*	288 sec
Reduced Almanac	31* or 12	20 min**,****
Midi Almanac	37*	120 min**,****
EOP	32*	30 min****
UTC	33*	288 sec
Diff Correction	34* or 13 & 14	30 min****,****
GGTO	35*	288 sec****
Text	36* or 15	As needed****
Integrity Support Message+	40	288 sec ****
<p>* Also contains SV clock correction parameters. ** Complete set of SVs in the constellation. *** When Differential Corrections are available. **** Optional (interval applies if/when broadcast). + One ISM per maximum broadcast interval; However, users are not required but can accept multiple ISMs from any SVs. Users can refer to the future TSO and MSO for further details. † The intervals specified are maximum. As such, the broadcast intervals may be shorter than the specified value.</p>		

IS :

Message Data	Message Type Number	Maximum Broadcast Intervals †
Ephemeris	10 & 11	48 sec
Clock	Type 30's	48 sec
ISC, IONO	30*	288 sec
Reduced Almanac	31* or 12	20 min**,****
Midi Almanac	37*	120 min**,****
EOP	32*	30 min****
UTC	33*	288 sec
Diff Correction	34* or 13 & 14	30 min****,****
GGTO	35*	288 sec****
Text	36* or 15	As needed****
Integrity Support Message ⁺	40	288 sec ****
<p>* Also contains SV clock correction parameters. ** Complete set of SVs in the constellation. *** When Differential Corrections are available. **** Optional (interval applies if/when broadcast). ⁺ One ISM per maximum broadcast interval; However, users are not required but can accept multiple ISMs from any SVs. Users can refer to the future TSO and MSO for further details. [†] The intervals specified are maximum. As such, the broadcast intervals may be shorter than the specified value.</p>		