

IS-GPS-705
DRAFT

~~-DRAFT FOR ICWG DISCUSSION ONLY-~~

GLOBAL POSITIONING SYSTEM WING (GPSW)
SYSTEMS ENGINEERING & INTEGRATION

INTERFACE SPECIFICATION

IS-GPS-705

Revision A

Navstar GPS Space Segment / User Segment L5 Interfaces



AUTHENTICATED BY: _____
Technical Director
Global Positioning Systems Wing

DISTRIBUTION STATEMENT A. Approved for Public Release; Distribution is Unlimited

REVISIONS				
DESCRIPTION				DATE
IS-GPS-705, Initial Release				24 November 2003
IRN-705-001				05 January 2005
IRN-705-002				20 April 2005
IRN-705-003				22 September 2005
<u>IS-GPS-705, Rev A</u>				<u>TBD</u>
DISTRIBUTION STATEMENT A APPROVED FOR PUBLIC RELEASE; DISTRIBUTION IS UNLIMITED.				
APPROVALS				
AUTHORIZED SIGNATURES		REPRESENTING		DATE
Signature on file		GPS NAVSTAR JPO GPS Wing SMC/GP		31 Jan 2005
<u>Signature on file</u>		<u>GPS NAVSTAR GPS Wing</u> <u>SMC/GP</u>		<u>28 Jan 2010</u>
INTERFACE SPECIFICATION				
UNLESS OTHERWISE SPECIFIED: DIMENSIONS ARE IN INCHES. TOLERANCES ON: DECIMALS ANGLES XX = ±0.03 ±0° 30' XXX = ±0.01	DR			<u>Prepared by :</u> Science Applications International Corporation ARINC Engineering Services, LLC 2250300 N. Sepulveda E. Imperial Highway Blvd
	BY			
	CH			IS TITLE Navstar GPS Space Segment / User Segment L5 Interfaces
APPROVALS				
THIS DOCUMENT SPECIFIES TECHNICAL REQUIREMENTS AND NOTHING HEREIN CONTAINED SHALL BE DEEMED TO ALTER THE TERMS OF ANY CONTRACT OR PURCHASE ORDER BETWEEN ALL PARTIES AFFECTED.				SIZE A
				CODE IDENT NO. <u>4WNC10VXX</u> 4
				DRAWING NO. IS-GPS-705
				SCALE: N/A
				REV: <u>-N/A</u>
				SHEET <u>-1i</u>

(This page is intentionally left blank.)

(This page intentionally left blank)

Page Revision Record

<u>Pages</u>	<u>Revision</u>	<u>Pages</u>	<u>Revision</u>
i	IRN 705 003		
ii-iv	IS GPS 705		
v	IRN 705 003		
vi-vii	IS GPS 705		
viii	IRN 705 002		
ix-xii	IRN 705 001		
xiii	IRN 705 002		
xiv	IS GPS 705		
1-5	IRN 705 001		
6	IRN 705 002		
7	IRN 705 001		
8-12	IS GPS 705		
13	IRN 705 001		
14	IRN 705 002		
15-16	IS GPS 705		
17	IRN 705 002		
18-19	IS GPS 705		
20-23	IRN 705 001		
24-30	IS GPS 705		
31-33	IRN 705 001		
34	IRN 705 003		
35	IRN 705 001		
35a-35f	IRN 705 002		
36	IS GPS 705		
37	IRN 705 001		
38	IS GPS 705		
38a-70	IRN 705 001		
71-72	IRN 705 002		
73-95	IRN 705 001		

TABLE OF CONTENTS

1. SCOPE.....	16
1.1 SCOPE	16
1.2 IS APPROVAL AND CHANGES.....	16
2. APPLICABLE DOCUMENTS.....	18
2.1 GOVERNMENT DOCUMENTS.....	18
2.2 NON-GOVERNMENT DOCUMENTS.....	18
3. REQUIREMENTS	20
3.1 INTERFACE DEFINITION.....	20
3.2 INTERFACE IDENTIFICATION	21
3.2.1 Ranging Codes.....	21
3.2.1.1 L5-Codes	21
3.2.1.2 Non-Standard Codes.....	21
3.2.2 NAV Data.....	21
3.2.3 L5 Signal Structure.....	25
3.3 INTERFACE CRITERIA.....	25
3.3.1 Composite Signal.....	25
3.3.1.1 Frequency Plan	25
3.3.1.2 Correlation Loss.....	25
3.3.1.3 Carrier Phase Noise	25
3.3.1.4 Spurious Transmissions	27
3.3.1.5 Phase Quadrature	27
3.3.1.6 Signal Power Levels	27
3.3.1.6.1 Space Service Volume (SSV) Received Signal Power Levels.....	29
3.3.1.7 Equipment Group Delay	29
3.3.1.7.1 Group Delay Uncertainty	29
3.3.1.7.2 Group Delay Differential	29
3.3.1.7.3 Space Service Volume Group Delay Differential.....	30
3.3.1.8 Signal Coherence	30
3.3.1.9 Signal Polarization.....	30
3.3.2 PRN Code Characteristics.....	30
3.3.2.1 Code Structure	30
3.3.2.2 Code Generation	32
3.3.2.3 Q5 Synchronization Sequence	36
3.3.3 Navigation Data.....	36
3.3.3.1 Navigation Data Modulation.....	36
3.3.3.1.1 Forward Error Correction	37

3.3.3.1.2 Neuman-Hofman Code	39
3.3.4 GPS Time and SV Z-Count	39
4. NOT APPLICABLE.....	42
5. NOT APPLICABLE.....	43
6. NOTES.....	44
6.1 ACRONYMS	44
6.2 DEFINITIONS	47
6.2.1 User Range Accuracy	47
6.2.2 SV Block Definitions.....	47
6.2.2.1 Developmental SVs	47
6.2.2.2 Operational SVs.....	47
6.2.2.2.1 Block IIA SVs.....	47
6.2.2.2.2 Block IIR SVs.....	47
6.2.2.2.4 Block IIF SVs	47
6.2.2.2.5 Block III SVs	47
6.2.3 Operational Interval Definitions.....	47
6.2.4 GPS Week Number	47
6.3 SUPPORTING MATERIAL	48
6.3.1 L5 Received Signals.....	48
6.3.2 Integrated Phase Noise Characteristics	48
6.3.3 Ellipticity Characteristics	48
6.3.4 Additional PRN Sequences	49
10. APPENDIX I. LETTERS OF EXCEPTION.....	57
10.1 SCOPE	57
10.2 APPLICABLE DOCUMENTS.....	57
10.3 LETTERS OF EXCEPTION.....	57
20 APPENDIX II. GPS NAVIGATION DATA STRUCTURE FOR L5 CNAV DATA, D5(T).....	61
20.1 SCOPE	61
20.2 APPLICABLE DOCUMENTS.....	61
20.2.1 GOVERNMENT DOCUMENTS.....	61
20.2.2 Non-Government Documents.....	61
20.3 REQUIREMENTS	62
20.3.1 Data Characteristics.....	62
20.3.2 Message Structure	62
20.3.3 Message Content.....	62

20.3.3.1	Message Types 10 and 11 Ephemeris and Health Parameters	78
20.3.3.1.1	Message Types 10 and 11 Ephemeris and Health Parameter Content	78
20.3.3.1.2	Message Types 10 and 11 Ephemeris Parameter Characteristics	82
20.3.3.1.3	User Algorithm for Determination of SV Position	82
20.3.3.2	Message Types 30 through 37 SV Clock Correction Parameters	87
20.3.3.2.1	Message Types 30 through 37 SV Clock Correction Parameter Content	87
20.3.3.2.2	Clock Parameter Characteristics	87
20.3.3.2.3	User Algorithms for SV Clock Correction Data	87
20.3.3.2.4	SV Clock Accuracy Estimates	88
20.3.3.3	Message Type 30 Ionospheric and Group Delay Correction Parameters.....	92
20.3.3.3.1	Message Type 30 Ionospheric and Group Delay Correction Parameter Content.....	92
20.3.3.4	Message Types 31, 12 and 37 Almanac Parameters	98
20.3.3.4.1	Almanac Reference Week.....	98
20.3.3.4.2	Almanac Reference Time	98
20.3.3.4.3	SV PRN Number	98
20.3.3.4.4	Signal Health (L1/L2/L5)	98
20.3.3.4.5	Midi Almanac Parameter Content.....	98
20.3.3.4.6	Reduced Almanac Parameter Content	100
20.3.3.5	Message Type 32 Earth Orientation Parameters (EOP).....	101
20.3.3.5.1	EOP Content	101
20.3.3.6	Message Type 33 Coordinated Universal Time (UTC) Parameters.....	106
20.3.3.6.1	UTC Parameter Content.....	106
20.3.3.6.2	UTC and GPS Time.....	106
20.3.3.7	Message Types 34, 13, and 14 Differential Correction Parameters.....	108
20.3.3.7.1	Differential Correction Parameters Content.....	108
20.3.3.7.2	DC Data Packet.....	108
20.3.3.7.3	Application of Clock-Related Differential Correction Data	111
20.3.3.7.4	Application of Orbit-Related Differential Correction Data	111
20.3.3.7.5	SV Differential Range Accuracy Estimates.....	113
20.3.3.8	Message Type 35 GPS/GNSS Time Offset	114
20.3.3.8.1	GPS/GNSS Time Offset Parameter Content.....	114
20.3.3.8.2	GPS and GNSS Time.....	114
20.3.3.9	Message Types 36 and 15 Text Messages	115
20.3.4	<i>Timing Relationships</i>	115
20.3.4.1	Paging and Cutovers	115
20.3.4.2	SV Time vs. GPS Time.....	117
20.3.5	<i>Data Frame Parity</i>	118

20.3.5.1 Parity Algorithm	118
---------------------------------	-----

LIST OF FIGURES

Figure 3-1. GPS Space Segment to User Segment Interfaces..... 20

Figure 3-2. Generation of Codes 31

Figure 3-3. Modulation of Signals..... 32

Figure 3-4. XA Shift Register Generator Configuration..... 34

Figure 3-5. XB Shift Register Generator Configuration..... 35

Figure 3-6. Relative Phases between the XA and XB Sequences..... 36

Figure 3-7. Convolution Encoder 38

Figure 3-8. Convolution Transmit/Decoding Timing Relationships 38

Figure 3-9. Time Line Relationship of a Six-Second Message 41

Figure 6-1. Carrier Phase Noise Spectral Density 48

Figure 10-1. Letters of Exception 59

Figure 10-1. Letters of Exception 60

Figure 20-1. Message type 10 - Ephemeris 1 64

Figure 20-2. Message type 11 - Ephemeris 2 65

Figure 20-3. Message type 30 - Clock, IONO & Group Delay 66

Figure 20-4. Message type 31 - Clock & Reduced Almanac..... 67

Figure 20-5. Message type 32 - Clock & EOP 68

Figure 20-6. Message type 33 - Clock & UTC..... 69

Figure 20-7. Message type 34 - Clock & Differential Correction 70

Figure 20-8. Message type 35 - Clock & GGTO..... 71

Figure 20-9. Message type 36 - Clock & Text..... 72

Figure 20-10. Message Type 37 - Clock & Midi Almanac 73

Figure 20-11. Message type 12 -Reduced Almanac 74

Figure 20-12. Message type 13 - Clock Differential Correction 75

Figure 20-13. Message type 14 - Ephemeris Differential Correction 76

Figure 20-14. Message type 15 - Text 77

Figure 20-15. Sample Application of Correction Parameters..... 97

Figure 20-16. Reduced Almanac Packet Content 101

Figure 20-17. Differential Correction Data Packet..... 109

LIST OF TABLES

Table 3-I. Code Phase Assignments (sheet 2 of 2)	24
Table 3-II. Composite L5 Transmitted Signal Phase**	28
Table 3-III. Received Minimum RF Signal Strength.....	28
Table 3-IV. Space Service Volume (SSV) Received Minimum RF Signal Strength for GPS III and Subsequent Satellites over the Bandwidth Specified in 3.3.1.1	29
Table 6-I. Typical Ellipticity vs Angular Range.....	49
Table 6-II. Additional Code Phase Assignments (sheet 1 of 6).....	49
Table 6-II. Additional Code Phase Assignments (sheet 2 of 6).....	51
Table 6-II. Additional Code Phase Assignments (sheet 3 of 6).....	52
Table 6-II. Additional Code Phase Assignments (sheet 4 of 6).....	53
Table 6-II. Additional Code Phase Assignments (sheet 5 of 6).....	54
Table 6-II. Additional Code Phase Assignments (sheet 6 of 6).....	55
Table 20-I. Message Types 10 and 11 Parameters (1 of 2).....	83
Table 20-I. Message Types 10 and 11 Parameters (2 of 2)	84
Table 20-II. Elements of Coordinate System (part 1 of 2).....	85
Table 20-II. Elements of Coordinate System (part 2 of 2).....	86
Table 20-III. Clock Correction and Accuracy Parameters	88
Table 20-IV. Group Delay Differential Parameters ****	93
Table 20-V. Midi Almanac Parameters.....	99
Table 20-VI. Reduced Almanac Parameters.....	101
Table 20-VII. Earth Orientation Parameters.....	103
Table 20-VIII. Application of EOP Parameters (Part 1 of 2)	104
Table 20-VIII. Application of EOP Parameters (Part 2 of 2)	105
Table 20-IX. UTC Parameters.....	107
Table 20-X. Differential Correction Parameters.....	110
Table 20-XI. GPS/GNSS Time Offset Parameters.....	115
Table 20-XII. Message Broadcast Intervals.....	116

|

|

~~(This page intentionally left blank.)~~

1. SCOPE

1.1 Scope. This Interface Specification (IS) defines the requirements related to the interface between the Space Segment (SS) of the Global Positioning System (GPS) and the navigation User Segment (US) of the GPS for radio frequency (RF) link 5 (L5).

1.2 IS Approval and Changes. ~~Applications International Corporation (SAIC) ARINC Engineering Services, LLC has been designated~~ the Interface Control Contractor (ICC) ~~designated by the government is, and is~~ responsible for the basic preparation, obtaining approval coordination, distribution, retention, and Interface Control Working Group (ICWG) coordination of the IS in accordance with GP-03-001. The Navstar GPS Wing (GPSW) Joint Program Office is the necessary authority to make this IS effective. The Joint Program Office (JPO)GPSW administers approvals under the auspices of the Configuration Control Board (CCB), which is governed by the appropriate JPO GPSW Operating Instruction (OI). Military organizations and contractors are represented at the CCB by their respective segment member. All civil organizations and public interest are represented by the Department of Transportation representative of the GPS-JPOGPSW.

A proposal to change the approved version of this IS can be submitted by any ICWG participating organization to the GPS-JPOGPSW and/or the ICC. The ICC is responsible for the preparation of the change paper and change coordination, in accordance with GP-03-001. The ICC prepares the change paper as a Proposed Interface Revision Notice (PIRN) and is responsible for coordination of PIRNs with the ICWG. The ICWG coordinated PIRN must be submitted to the GPS-JPOGPSW CCB for review and approval.

The ICWG review period for all Proposed Interface Revision Notices (PIRNs) is 45 days after receipt by individual addressees. A written request to extend the review period may be submitted to the ICC for consideration.

(This page intentionally left blank.)

2. APPLICABLE DOCUMENTS

2.1 Government Documents. The following documents of the issue specified contribute to the definition of the interfaces between the GPS Space Segment and the GPS navigation User Segment (US), and form a part of this IS to the extent specified herein.

Specifications

Federal

None

Military

None

Other Government Activity

None

Standards

Federal

None

Military

None

Other Publications

IS-GPS-200
current issue

Navstar GPS Space Segment / Navigation
User Interfaces

GP-03-001
~~14 Nov 2003~~ [current issue](#)

GPS Interface Control Working Group
(ICWG) Charter

2.2 Non-Government Documents. The following documents of the issue specified contribute to the definition of the interfaces between the GPS SS and the GPS Navigation US and form a part of this IS to the extent specified herein.

Specifications

None

Other Publications

None

~~(This page intentionally left blank.)~~

3. REQUIREMENTS

3.1 Interface Definition. The signal interface between the GPS SS and the GPS Navigation US includes three radio frequency (RF) links: L1, L2 and L5. Figure 3-1 illustrates the interface between the SS and the users. The L5 link is only available on Block IIF and the ~~planned future subsequent~~ Blocks of III SVs. Utilizing these links, the space vehicles (SVs) of the SS shall provide continuous earth coverage signals that provide to the users the ranging codes and the system data needed to accomplish the GPS Navigation (NAV) mission. These signals shall be available to a suitably equipped user with RF visibility to an SV, including users in terrestrial and near-terrestrial applications as well as users in orbital applications up to geostationary altitude. The civil functions of the L1 and L2 RF links are specified in IS-GPS-200. Only the L5 link and its relationship with the L1 and L2 links are specified herein.

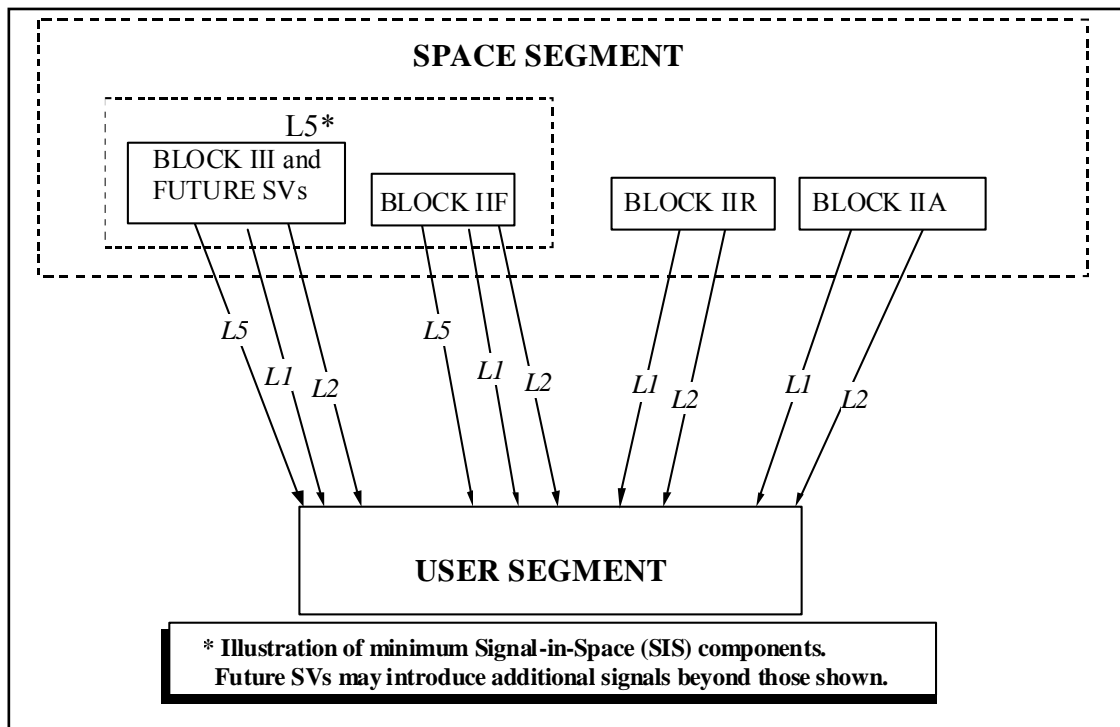

Figure 3-1. GPS Space Segment to User Segment Interfaces

3.2 Interface Identification. The carriers of the L5 are typically modulated by two bit trains in phase quadrature. One is a composite bit train generated by the modulo-2 addition of a pseudo-random noise (PRN) ranging code, a synchronization sequence (see paragraph 3.3.3.1.2), and the downlink system data (referred to as L5 CNAV (civil navigation) data), and the second is modulated with a PRN ranging code and synchronization sequence (see paragraph 3.3.2.3) that differ from those used with the L5 CNAV data.

3.2.1 Ranging Codes. Two PRN ranging codes are transmitted on L5: the in-phase code (denoted as the I5-code); and the quadrature code (denoted as the Q5-code). Code-division-multiple-access techniques allow differentiating between the SVs even though they may transmit at the same L5 frequency. The SVs shall transmit intentionally "incorrect" versions of the I5 and the Q5-codes when needed to protect the users from receiving and utilizing anomalous NAV signals. These two "incorrect" codes are termed non-standard I5 (NSI5) and non-standard Q5 (NSQ5) codes.

3.2.1.1 L5-Codes. The PRN ranging codes $I5_i(t)$ and $Q5_i(t)$ for SV ID number i are independent, but time synchronized, 1 millisecond in length, with a chipping rate of 10.23 Mbps. For each code, the 1-millisecond sequences are the modulo-2 sum of two sub-sequences referred to as XA and XB_i ; their lengths are 8,190 chips and 8,191 chips, respectively that restart to generate the 10,230 chip code. The XB_i sequence is selectively advanced, thereby allowing the basic code generation technique to produce different code sequences of 1-millisecond in length. Of these, 32 pairs are currently designated for use by SVs and 5 pairs are currently reserved. Assignment of these code phase segments by SV ID number (or other use) is given in Table 3-I. SV ID and PRN numbers are identical to those for the L1 and L2 signals as specified in IS-GPS-200.

The 74 codes (37 I5-codes and 37 Q5-codes) are a selected subset of over 4,000 possible codes that could be generated using the selective advance. The remaining codes are available for future use of additional SVs and/or other L5 signal applications such as Satellite-Based Augmentation System (SBAS) satellite signals. Of the remaining codes, Section 6.3.4 provides a selected subset of codes with assigned PRN numbers.

3.2.1.2 Non-Standard Codes. The NSI5 and NSQ5 codes, used to protect the user from ~~receiving tracking anomalous NAV navigation signals~~ ~~a malfunction in the SV's reference frequency generation system (reference paragraph 3.2.1)~~, are not for utilization by the user and, therefore, are not defined in this document. The SVs shall also be capable of initiating and terminating the broadcast of NSI5 and/or NSQ5 code(s) independently of each other, in response to Control Segment (CS) command.

3.2.2 NAV Data. The L5 CNAV data, $D_5(t)$, includes SV ephemerides, system time, SV clock behavior data, status messages and time information, etc. The 50 bps data is encoded in a rate 1/2 convolution encoder. The resulting 100 symbols per second (sps) symbol stream is modulo-2 added to the I5-code only; the resultant bit-train is used to

modulate the L5 in-phase (I) carrier. The content and characteristics of the L5 CNAV data, $D_5(t)$, are given in Appendix II of this document. In general, the data content is very similar to that modulated on the L2 C channel of the SV.

The L5 quadrature (Q) carrier has no data.

Table 3-I. Code Phase Assignments (sheet 1 of 2)

GPS PRN Signal No.*	XB Code Advance – Chips**		Initial XB Code State***	
	I5	Q5	I5	Q5
1	266	1701	0101011100100	1001011001100
2	365	323	1100000110101	0100011110110
3	804	5292	0100000001000	1111000100011
4	1138	2020	1011000100110	0011101101010
5	1509	5429	1110111010111	0011110110010
6	1559	7136	0110011111010	0101010101001
7	1756	1041	1010010011111	1111110000001
8	2084	5947	1011110100100	0110101101000
9	2170	4315	1111100101011	1011101000011
10	2303	148	0111111011110	0010010000110
11	2527	535	0000100111010	0001000000101
12	2687	1939	1110011111001	0101011000101
13	2930	5206	0001110011100	0100110100101
14	3471	5910	0100000100111	1010000111111
15	3940	3595	0110101011010	1011110001111
16	4132	5135	0001111001001	1101001011111
17	4332	6082	0100110001111	1110011001000
18	4924	6990	1111000011110	1011011100100
19	5343	3546	1100100011111	0011001011011

* PRN sequences 33 through 37 are reserved for other uses (e.g. ground transmitters).
 ** XB Code Advance is the number of XB clock cycles beyond an initial state of all 1s.
 *** In the binary notation for the first 13 chips of the I5 and Q5 XB codes as shown in these columns. The rightmost bit is the first bit out. Since the initial state of the XA Code is all 1s, these first 13 chips are also the complement of the initial states of the I5 or Q5-codes.

NOTE: The code phase assignments constitute inseparable pairs, each consisting of a specific I5 and a specific Q5-code phase, as shown above.

Table 3-I. Code Phase Assignments (sheet 2 of 2)

GPS PRN Signal No.*	XB Code Advance – Chips**		Initial XB Code State***	
	I5	Q5	I5	Q5
20	5443	1523	0110101101101	1100001110001
21	5641	4548	0010000001000	0110110010000
22	5816	4484	1110111101111	0010110001110
23	5898	1893	1000011111110	1000101111101
24	5918	3961	1100010110100	0110111110011
25	5955	7106	1101001101101	0100010011011
26	6243	5299	1010110010110	0101010111100
27	6345	4660	0101011011110	1000011111010
28	6477	276	0111101010110	1111101000010
29	6518	4389	0101111100001	0101000100100
30	6875	3783	1000010110111	1000001111001
31	7168	1591	0001010011110	0101111100101
32	7187	1601	0000010111001	1001000101010
33	7329	749	1101010000001	1011001000100
34	7577	1387	1101111111001	1111001000100
35	7720	1661	1111011011100	0110010110011
36	7777	3210	1001011001000	0011110101111
37	8057	708	0011010010000	0010011010001

* PRN sequences 33 through 37 are reserved for other uses (e.g. ground transmitters).
 ** XB Code Advance is the number of XB clock cycles beyond an initial state of all 1s.
 *** In the binary notation for the first 13 chips of the I5 and Q5 XB codes as shown in these columns. The rightmost bit is the first bit out. Since the initial state of the XA Code is all 1s, these first 13 chips are also the complement of the initial states of the I5 or Q5-codes.

NOTE: The code phase assignments constitute inseparable pairs, each consisting of a specific I5 and a specific Q5-code phase, as shown above.

3.2.3 L5 Signal Structure. The L5 consists of two carrier components that are in phase quadrature with each other. Each carrier component is bi-phase shift key (BPSK) modulated by a separate bit train. One bit train is the modulo-2 sum of the I5-code, NAV data, and synchronization sequence while the other is the Q5-code with no NAV data, but with another synchronization sequence. For a particular SV, all transmitted signal elements (carriers, codes, synchronization sequences, and data) are coherently derived from the same on-board frequency source.

3.3 Interface Criteria. The criteria specified in the following define the requisite characteristics of the L5 interface.

3.3.1 Composite Signal. The following criteria define the characteristics of the composite L5 signal.

3.3.1.1 Frequency Plan. ~~The requirements specified in this document shall pertain to the signal contained within 24 MHz band centered about the L5 nominal frequency. The L5 signal is contained within a 24 MHz band centered about the L5 nominal frequency.~~ The carrier frequencies for the L1, L2 and L5 signals shall be coherently derived from a common frequency source within the SV. The nominal frequency of this source -- as it appears to an observer on the ground -- is 10.23 MHz. The SV carrier frequency and clock rates -- as they would appear to an observer located in the SV -- are offset to compensate for relativistic effects. The clock rates are offset by $\Delta f/f = -4.4647E-10$, equivalent to a change in the I5 and Q5-code chipping rate of 10.23 MHz offset by a $\Delta f = -4.5674E-3$ Hz. This is equal to 10.2299999954326 MHz. The nominal carrier frequency (f_0) -- as it appears to an observer on the ground -- shall be 1176.45 MHz, or 115 times 10.23 MHz.

3.3.1.2 Correlation Loss.

~~Correlation loss is defined as the difference between the SV power received in the bandwidth defined in 3.3.1.1 (excluding signal combining loss) and the signal power recovered in an ideal correlation receiver of the same bandwidth using an exact replica of the waveform within an ideal sharp-cutoff filter bandwidth centered at L5, whose bandwidth corresponds to that specified in 3.3.1.1 and whose phase is linear over that bandwidth. The correlation loss apportionment due to SV modulation and filtering imperfections shall be 0.6 dB maximum.~~

~~Correlation loss is defined as the difference between the SV power received in a 24 MHz bandwidth and the signal power recovered in an ideal correlation receiver. The worst case correlation loss occurs when the I5 carrier is modulated by the sum of the I5 code and the NAV data stream. For this case, the correlation loss apportionment shall be as follows:~~

- ~~1. ——— SV modulation and filter imperfections: 0.6 dB~~
- ~~2. ——— Ideal UE receiver waveform distortion (due to 24 MHz filter): 0.4 dB~~

3.3.1.3 Carrier Phase Noise.

The phase noise spectral density of the un-modulated carrier shall be such that a phase locked loop of 10 Hz one-sided noise bandwidth shall be able to track the carrier to an accuracy of 0.1 radians root mean square (RMS). See additional supporting material for phase noise characteristics in section 6.3.2.

3.3.1.4 Spurious Transmissions. In-band spurious transmissions, from the SV, shall be at or below least -40 dBc below the unmodulated L5 carrier over the band specified in 3.3.1.1. In-band spurious transmissions are defined as transmissions within the band specified in 3.3.1.1 which are not expressly components of the L5 signals. ~~In-band spurious transmissions, from the SV, shall be at least 40 dB below the un-modulated L5 carrier over the allocated 24 MHz channel bandwidth.~~

3.3.1.5 Phase Quadrature. The two L5 carrier components modulated by the two separate bit trains (I5-code plus data and Q5-code with no data) shall be in phase quadrature (within ± 100 milliradians) with the Q5 signal carrier lagging the I5 signal by 90 degrees. Referring to the phase of the I5 carrier when $I5_i(t)$ equals zero as the "zero phase angle₂"; the I5 and Q5-code generator output shall control the respective signal phases in the following manner: when $I5_i(t)$ equals one, a 180-degree phase reversal of the I5-carrier occurs; when $Q5_i(t)$ equals one, the Q5 carrier advances 90 degrees; when the $Q5_i(t)$ equals zero, the Q5 carrier shall be retarded 90 degrees (such that when $Q5_i(t)$ changes state, a 180-degree phase reversal of the Q5 carrier occurs). The resultant nominal composite transmitted signal phases as a function of the binary state of the modulating signals are as shown in Table 3-II.

3.3.1.6 Signal Power Levels. The SV shall provide, at a minimum, worst-case I5 and Q5 navigation signal strength at end-of-life (EOL), ~~worst-case~~ in order to meet the ~~minimum~~ levels specified in Table 3-III. The minimum received power is measured at the output of a 3 dBi linearly polarized user receiving antenna (located near ground) at worst normal orientation, when the SV is above a 5-degree elevation angle. The received signal levels are observed within the in-band allocation defined in paragraph 3.3.1.1. Additional related data is provided as supporting material in paragraph 6.3.1.

The Block III SV shall provide L5 signals with the following characteristic: the L5 off-axis power gain relative power (referenced to peak transmitted power)- shall not decrease by more than 2 dB from the Edge-of-Earth (EOE) to nadir, and no more than 18 dB from EOE to 26 degrees off nadir; the power drop off between EOE and ± 26 degrees shall be in a monotonically decreasing fashion.

Table 3-II. Composite L5 Transmitted Signal Phase**		
Nominal Composite L5 Signal Phase*	Code State	
	I5	Q5
0°	0	0
-90°	1	0
+90°	0	1
180°	1	1

* Relative to 0, 0 code state with positive angles leading and negative angles lagging.
 ** Based on the composite of two L5 carrier components at the same power.

Table 3-III. Received Minimum RF Signal Strength		
SV Blocks	Signal	
	I5	Q5
IIF	-157.9 dBW	-157.9 dBW
<u>III A</u>	<u>-157.0 dBW</u>	<u>-157.0 dBW</u>

Table 3-IV. Space Service Volume (SSV) Received Minimum RF Signal Strength for GPS III A and Subsequent Satellites over the Bandwidth Specified in 3.3.1.1 (GEO Based Antennas)

<u>SV Blocks</u>	<u>Signal</u>	
	<u>I5</u>	<u>Q5</u>
<u>III and Subsequent</u>	<u>-182.0 dBW</u>	<u>-182.0 dBW</u>

3.3.1.6.1 Space Service Volume (SSV) Received Signal Power Levels. The SV shall provide, at a minimum, worst-case I5 and Q5 navigation signal strength at end-of-life (EOL), ~~worst case~~ in order to meet the SSV ~~minimum~~ levels specified in Table 3-IV. The minimum received power is measured at the output of a 0 dBi right-hand circularly polarized (i.e. 0 dB axial ratio) user receiving antenna at ~~worst polarization~~ normal orientation at the off-nadir angle of 26.0 degrees. The received signal levels are observed within the in-band allocation defined in paragraph 3.3.1.1.

<u>Table 3-IV. Space Service Volume (SSV) Received Minimum RF Signal Strength for GPS III and Subsequent Satellites over the Bandwidth Specified in 3.3.1.1 – GEO Based Antennas</u>		
<u>SV Blocks</u>	<u>Signal</u>	
	<u>I5</u>	<u>Q5</u>
<u>III and Subsequent</u>	<u>-182.0 dBW</u>	<u>-182.0 dBW</u>

3.3.1.7 Equipment Group Delay. Equipment group delay is defined as the delay between the signal radiated output of a specific SV (measured at the antenna phase center) and the output of that SV's on-board frequency source; the delay consists of a bias term and an uncertainty. The bias term on L1/L2 P(Y) is of no concern to the users since it is included in the clock correction parameters relayed in the NAV data, and is therefore accounted for by ~~the~~ user computations of system time (reference paragraphs 20.3.3.2.3, 20.3.3.3.2.3 and 20.3.3.3.2.4). The uncertainty (variation) of these delays as well as the group delay differential between the signals of L1, L2, and L5 are defined in the following.

3.3.1.7.1 Group Delay Uncertainty. The effective uncertainty of the group delays shall not exceed 3.0 nanoseconds (~~two sigma~~95% probability).

3.3.1.7.2 Group Delay Differential. The group delay differential between the radiated L1 and L5 signals (i.e. L1 P(Y) and L5 I5; and L1 P(Y) and L5 Q5) is specified as consisting of random plus bias components. The mean differential is defined as the bias component and will be either positive or negative. For a given navigation payload redundancy configuration, the absolute value of the mean differential delay shall not exceed 30.0 nanoseconds. The random ~~plus non-random~~ variations about the mean shall not exceed 3.0 nanoseconds (~~two sigma~~95% probability), when including consideration of the temperature and antenna effects during a vehicle orbital revolution. L1 and L2 group delay differential is described in 3.3.1.7.2 of IS-GPS-200. Corrections for the bias components of the group delay differential are provided to the users in the NAV message using parameters designated as T_{GD} (reference paragraph 20.3.3.3.3.2 of IS-GPS-200) and Inter-Signal Correction (ISC) (reference paragraph 20.3.3.3.1.2).

3.3.1.7.3 Space Service Volume Group Delay Differential. The group delay differential between the radiated L5 signal, with respect to the Earth Coverage signal, for users of the Space Service Volume are provided in TBD.

3.3.1.8 Signal Coherence. All transmitted signals on the same carrier for a particular SV shall be coherently derived from the same on-board frequency standard. On the L5 channel, the chip transitions of the two modulating signals, L5I and L5Q, shall be such that the average time difference between them, and between each and the transitions of L1P(Y), do not exceed 10 nanoseconds. The variable time difference shall not exceed 1 nanosecond (95% probability), when including consideration of the temperature and antenna effect changes during a vehicle orbital revolution. Corrections for the bias components of the group delay differential are provided to the users using parameters designated as ISCs (reference paragraph 20.3.3.3.1.2).

~~L5 transmitted signals for a particular SV shall be coherently derived from the same on-board frequency standard. All PRN signals shall be clocked coherently with the P(Y) code signal transitions. On the L5 channel the chip transitions of the two modulating signals (i.e., that containing the I5-code and that containing the Q5-code) shall be such that the average time difference between the transitions does not exceed 10.0 nanoseconds (two-sigma).~~

3.3.1.9 Signal Polarization. The transmitted signal shall be right-hand circularly polarized (RHCP). For ~~the angular range of ± 14.3 degrees from boresight, L5 ellipticity shall be no worse than 2.4 dB. For Block IIIA the angular range of ± 13.8 degrees from nadir, L5 ellipticity shall be no worse than 2.4 dB.~~ Nominal values are listed in section 6.3.3.

3.3.2 PRN Code Characteristics. The characteristics of the I5-codes and the Q5-codes are defined below in terms of their structure and the basic method used for generating them. Figures 3-2 and 3-3 depict simplified block diagrams of the scheme for generating the 10.23 Mbps $I5_i(t)$ and $Q5_i(t)$ patterns, and for modulo-2 summing the I5 patterns with the NAV bit train, $D_5(t)$, which is rate 1/2 encoded and clocked at 100 sps. In addition, the 100 sps ~~symbols~~ are modulated with a 10-bit Neuman-Hofman code that is clocked at 1 kHz. The resultant composite bit trains are then used to modulate the L5 in-phase carrier. The Q5-code is modulated with a 20-bit Neuman-Hofman code that is also clocked at 1 kHz.

3.3.2.1 Code Structure. The $I5_i(t)$ pattern (I5-code) and the $Q5_i(t)$ pattern (Q5-code) are both generated by the modulo-2 summation of two PRN codes, $XA(t)$ and $XBI_i(n_{Ii}, t)$ or $XBQ_i(n_{Qi}, t)$, where n_{Ii} and n_{Qi} are initial states of XBI_i and XBQ_i for satellite i . There are over 4000 unique L5 codes generated using different initial states of which 74 are currently assigned and identified in Table 3-I using the same basic code generator. Section 6.3.4 provides a

selected subset of additional L5-code sequences with assigned PRN numbers.

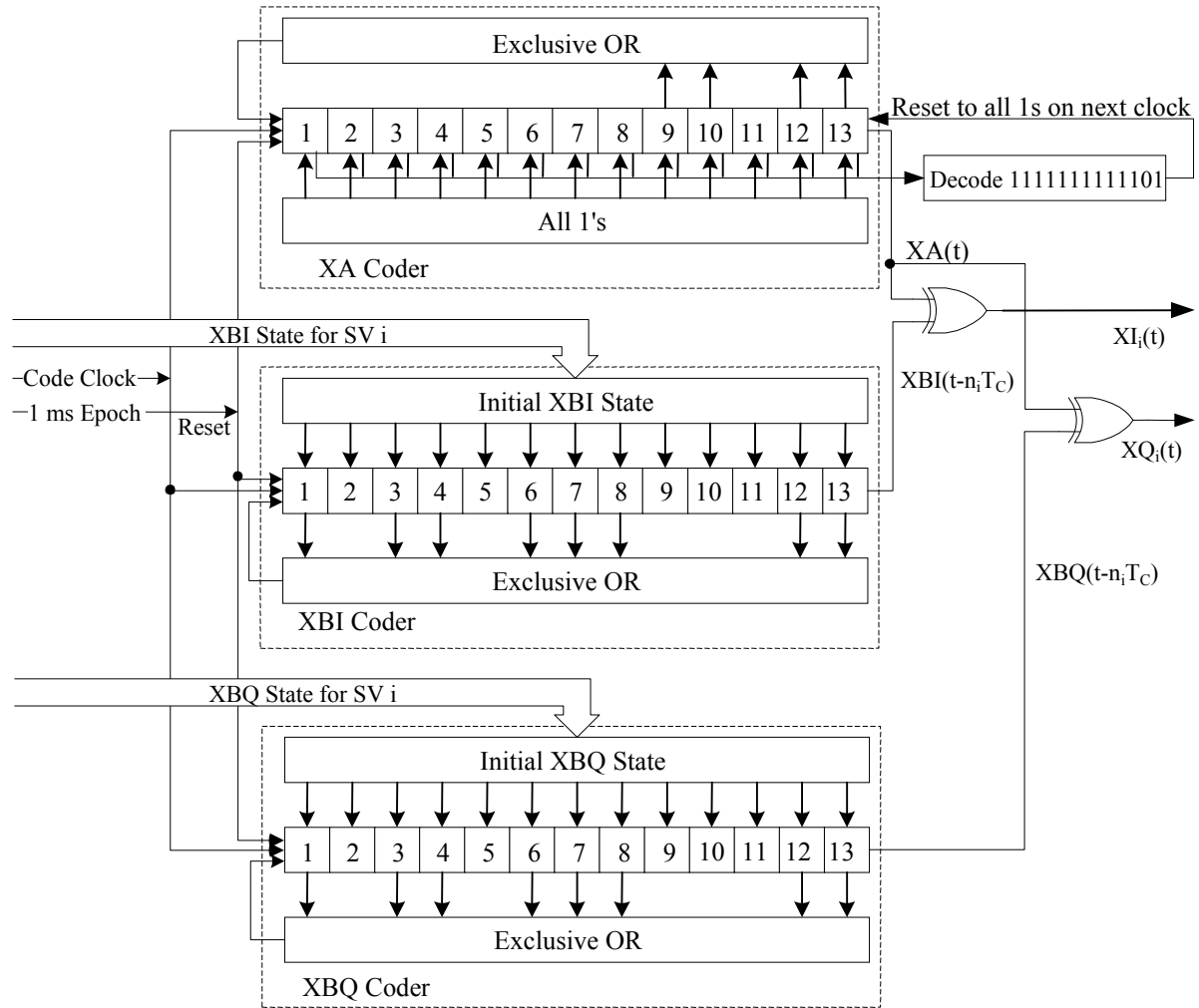

Figure 3-2. Generation of Codes

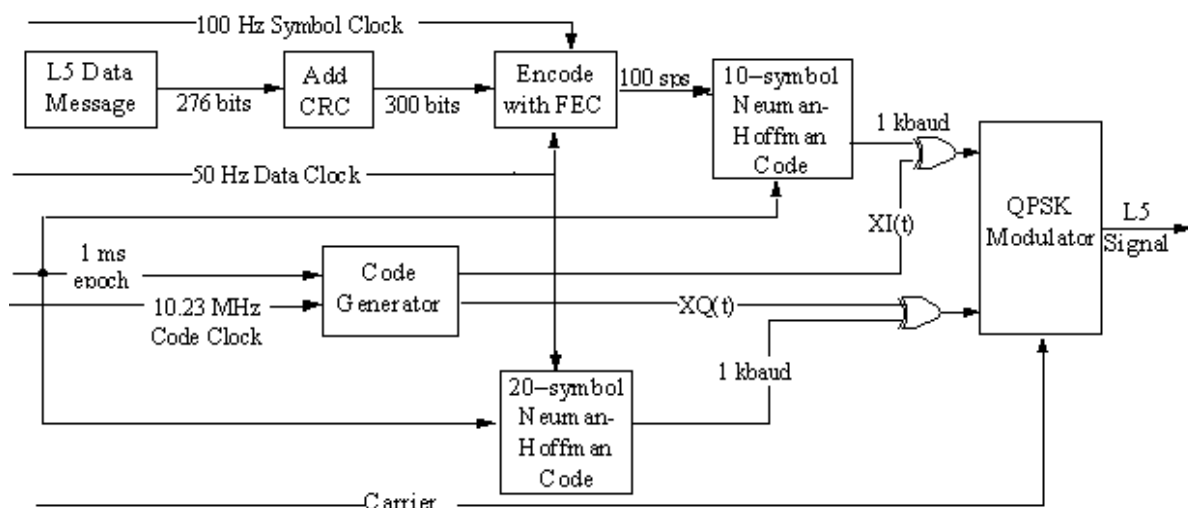

Figure 3-3. Modulation of Signals

3.3.2.2 Code Generation. Each $I5_i(t)$ pattern (I5-code) and $Q5_i(t)$ pattern (Q5-code) are the modulo-2 sum of two extended patterns clocked at 10.23 Mbps (XA and XBI_i or XBQ_i). XA is an 8190 length code, with an initial condition of all 1s, that is short cycled 1-chip before its natural conclusion and restarted to run over a period of 1 millisecond (synchronized with the L1 frequency C/A-code) for a total of 10,230 chips. The XBI_i and XBQ_i , with initial conditions indicated in Table 3-I, are 8191 length codes that are not short cycled. They are restarted at their natural completion and run over a period of 1 millisecond (synchronized with the XA code) for a total of 10,230 chips. The polynomials for XA and XBI_i or XBQ_i codes, as referenced to the shift register input, are:

$$\text{XA: } 1 + x^9 + x^{10} + x^{12} + x^{13}, \text{ and}$$

$$\text{XBI}_i \text{ or } \text{XBQ}_i: 1 + x + x^3 + x^4 + x^6 + x^7 + x^8 + x^{12} + x^{13}.$$

Samples of the relationship between shift register taps and the exponents of the corresponding polynomial, referenced to the shift register input, are as shown in Figures 3-4 (XA code) and 3-5 (XB code). In the case of the XB codes, the shift register can either be initialized with all 1s and advanced n_i states as specified in Table 3-I, or initialized with the state indicated in Table 3-I.

The state of each generator can be expressed as a code vector word which specifies the binary sequence constant of each register as follows: (a) the vector consists of the binary state of each stage of the register, (b) the stage 13 value appears at the right followed by the values of the remaining states in order of descending stage numbers, and (c) the shift direction is from lower to higher stage number with stage 13 providing the current output. This code vector convention represents the present output and 12 future outputs in sequence. Using this convention, at each XA epoch (state 8190), the XA shift register is initialized to the code vector 111111111111, while at each XB epoch (state 8191), the XB shift register is initialized to a code vector peculiar to the PRN number and phase. The XB code vectors are as indicated in Table 3-I. Alternatively, the XB shift register is initialized to the code vector 111111111111 and advanced n_i states as indicated in Table 3-I.

The natural 8191 chips of the XA sequence is shortened to 8190 chips to cause precession of the second XA sequence with respect to the natural 8191 chip XB sequence, as shown in Figure 3-6. Re-initialization of the XA shift register produces a 10230-chip sequence by omitting the last 6151 chips of the second natural XA sequence, or reinitializing to all 1s at the 1 ms epoch. The XB shift register is simply allowed to run its natural course until the next 1 ms epoch when it is reinitialized at its initial state, B0, based upon PRN number and phase. This results in the phase of the XB sequence leading by one chip during the second XA sequence in the 1-millisecond period. Depending upon the initial state of the XB sequence, a third 8191-chip sequence may be started before the 10230-chip sequence is completed. Two different scenarios that may result are shown in Figure 3-6.

In scenario a, the initial state of the XB sequence, B0, is less than State 6152. Thus, the second natural XB sequence does not run to completion prior to the next 1 ms epoch. In scenario b, the initial state of the XB sequence, B0, is greater than State 6151. Thus, the second natural XB sequence runs to completion and a third natural sequence starts (except when B0 is State 6152) prior to the next 1 ms epoch.

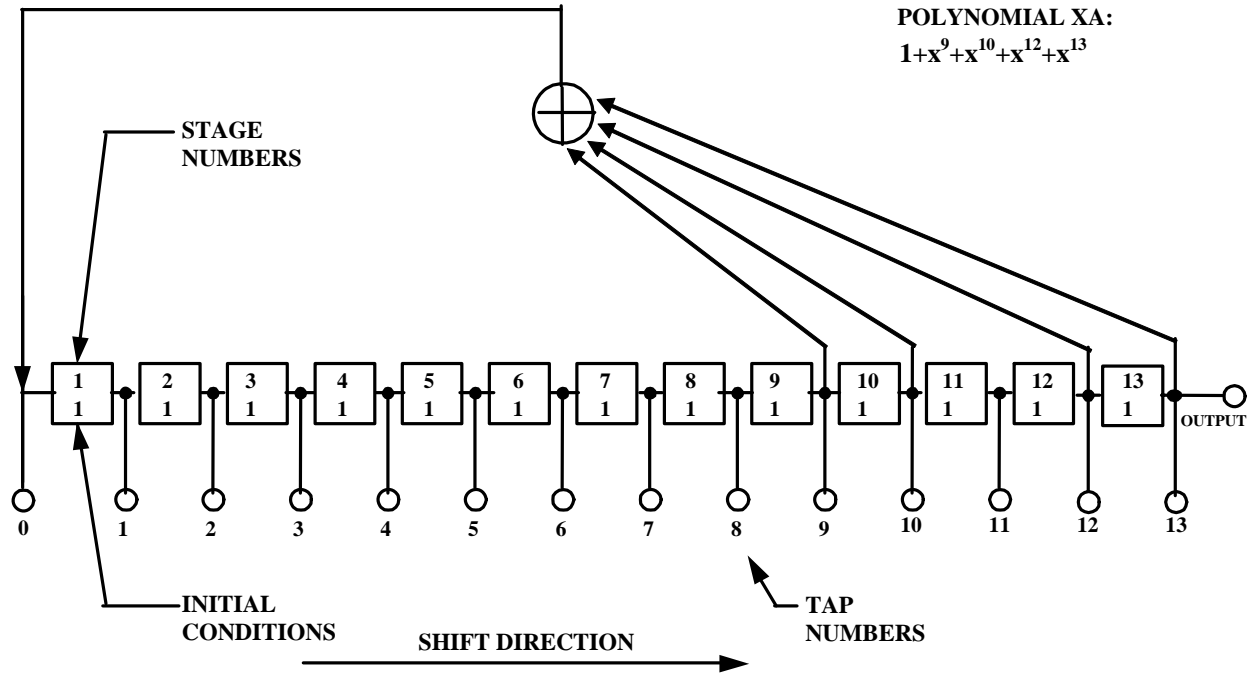

Figure 3-4. XA Shift Register Generator Configuration.

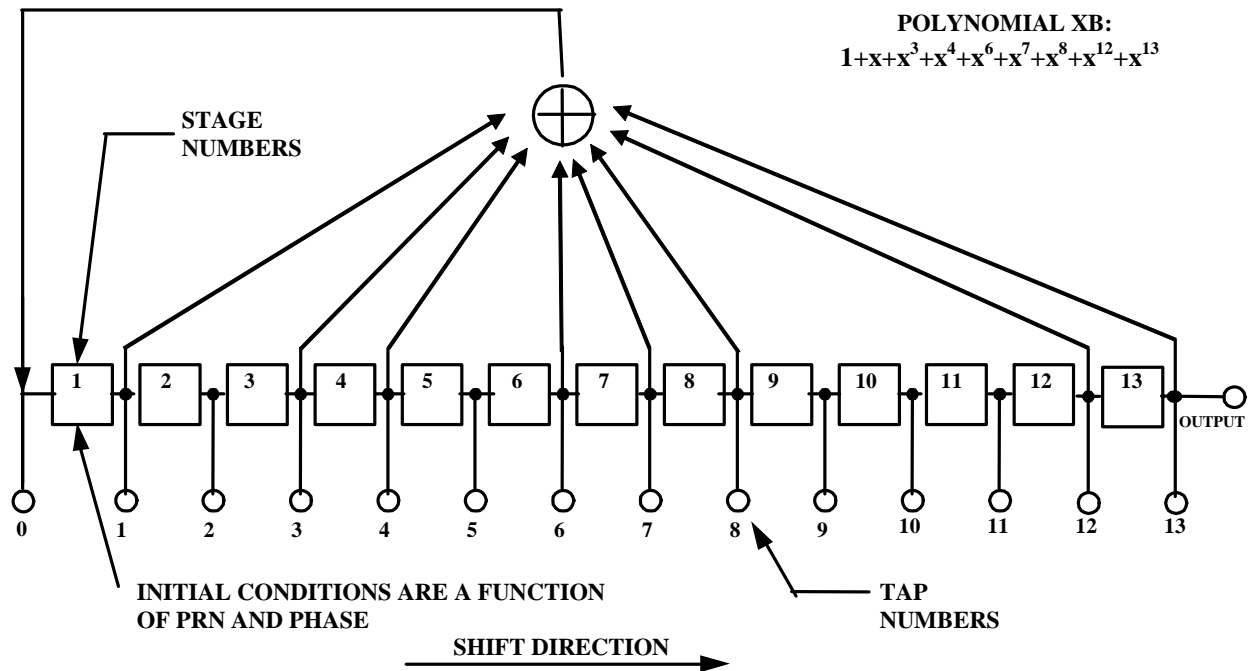

Figure 3-5. XB Shift Register Generator Configuration.

3.3.3.1.1 Forward Error Correction. The L5 CNAV bit train, $D_5(t)$, will always be rate 1/2 convolution encoded with a Forward Error Correction (FEC) code. Therefore, the symbol rate is 100 sps. The convolution coding will be constraint length 7, with a convolution encoder logic arrangement as illustrated in Figure 3-7. The G1 symbol is selected on the output as the first half of a 20-millisecond data bit period coincident with the first bit of the 20-bit Q5 Neuman-Hofman code.

Six-second navigation messages broadcast by the SV are synchronized with every fourth of the SV's P(Y)-code X1 epochs. Although these epochs are not necessarily accessible to the L5 user, they are used within the SV to define GPS time. However, message synchronization does provide the L5 user an access to the time of every 4th P(Y)-code X1 epoch. The navigation message is FEC encoded in a continuous process independent of message boundaries (i.e. at the beginning of each new message, the encoder registers illustrated in Figure 3-7 contains the last six bits of the previous message). Thus, herein, reference will continue to be made to these X1 epochs. See IS-GPS-200 for details.

The FEC encoding convolves successive messages. It is necessary to define which transmitted symbol is synchronized to SV time as follows. The beginning of the first symbol that contains any information about the first bit of a message will be synchronized to every fourth X1 epoch (referenced to end/start of week). The users' convolution decoders will introduce a fixed delay that depends on their respective algorithms (usually 5 constraint lengths, or 35 bits), for which they must compensate to determine system time from the received signal. This convolution decoding delay and the various relationships with the start of the data block transmission and SV timing are illustrated in Figure 3-8 for the L5 signal.

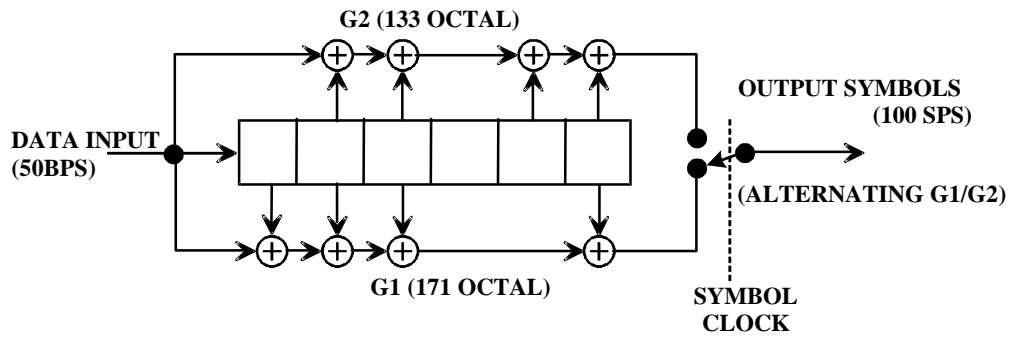

Figure 3-7. Convolution Encoder

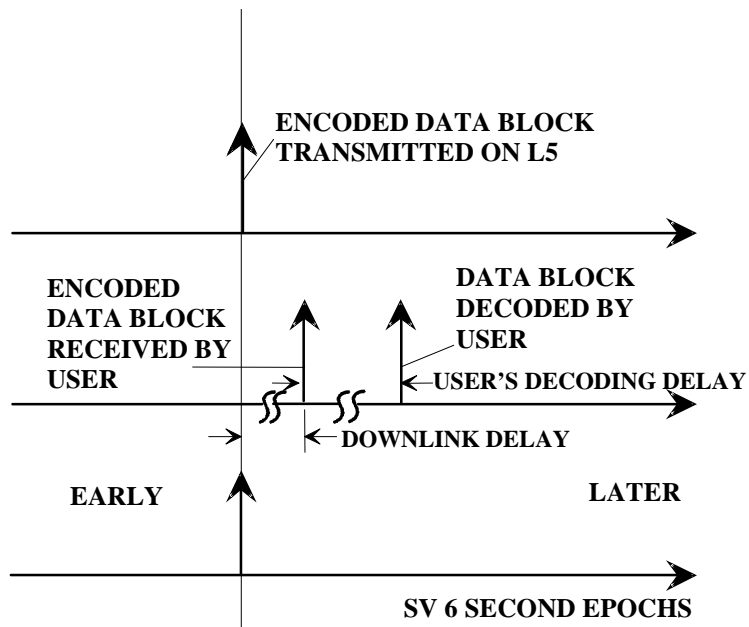

Figure 3-8. Convolution Transmit/Decoding Timing Relationships

3.3.3.1.2 Neuman-Hofman Code. Each of the 100 sps symbols are further encoded with a 10-bit Neuman-Hofman code. The 10-bit Neuman-Hofman code is defined to be 0000110101. The 10 bits are modulo-2 added to the symbols at the PRN code epoch rate of 1 kHz starting at the 100 sps symbol transitions. The result is that a "1" data symbol is replaced by 1111001010, and a "0" data symbol is replaced by 0000110101.

3.3.4 GPS Time and SV Z-Count. GPS time is established by the Operational Control System (OCS) and is referenced to Coordinated Universal Time (UTC) as maintained by the U.S. Naval Observatory (UTC(USNO)) zero time-point defined as midnight on the night of January 5, 1980/morning of January 6, 1980. GPS time is the ensemble of corrected composite L1/L2 P(Y) SV times, corrected via the clock corrections in the L1 and L2 NAV data and the relativity correction. The largest unit used in stating GPS time is one week defined as 604,800 seconds, concatenated with the GPS week number. GPS time may differ from UTC because GPS time is a continuous time scale, while UTC is corrected periodically with an integer number of leap seconds. There also is an inherent but bounded drift rate between the UTC and GPS time scales. The OCS controls the GPS time scale to be within one microsecond of UTC (modulo one second).

The L5 CNAV data contains the requisite data for relating GPS time to UTC. The accuracy of this data during the transmission interval will be such that it relates GPS time to UTC (USNO) to within 90.0 nanoseconds (one sigma). This data is generated by the CS (or provided to the CS); therefore, the accuracy of these relationships may degrade if for some reason the CS is unable to upload data to an SV.

In each SV the X1 epochs of the P-code ~~of the L1 and L2~~ offer a convenient unit for precisely counting and communicating time. Time stated in this manner is referred to as Z-count, which is given as a ~~29-bit~~ binary number consisting of two parts as follows:

- a. The binary number represented by the 19 least significant bits of the Z-count is referred to as the time of week (TOW) count and is defined as being equal to the number of X1 epochs that have occurred since the transition from the previous week. The count is short-cycled such that the range of the TOW-count is from 0 to 403,199 X1 epochs (equaling one week) and is reset to zero at the end of each week. The TOW-count's zero state is defined as that X1 epoch which is coincident with the start of the present week. This epoch occurs at (approximately) midnight Saturday night-Sunday morning, where midnight is defined as 0000 hours on the UTC scale, which is nominally referenced to the Greenwich Meridian. Over the years the occurrence of the "zero state epoch" may differ by a few seconds from 0000 hours on the UTC scale since UTC is periodically corrected with leap seconds while the TOW-count is continuous without such correction. A truncated version of the TOW-count, consisting of its 17 most significant bits, is contained in each of the six-second messages of the L5 downlink data stream; the relationship between the actual TOW-count and its truncated message version is illustrated by Figure 3-9.
- b. ~~The most significant bits of the Z-count are a binary representation of the sequential number assigned to the current GPS week (see paragraph 6.2.4). The ten most significant bits of the Z count are a modulo 1024 binary representation of the sequential number assigned to the current GPS week (see paragraph 6.2.4). The range of this count is from 0 to 1023 with its zero state being defined as the GPS week number zero and every integer multiple of 1024 weeks, thereafter (i.e. 0, 1024, 2048, etc.).~~

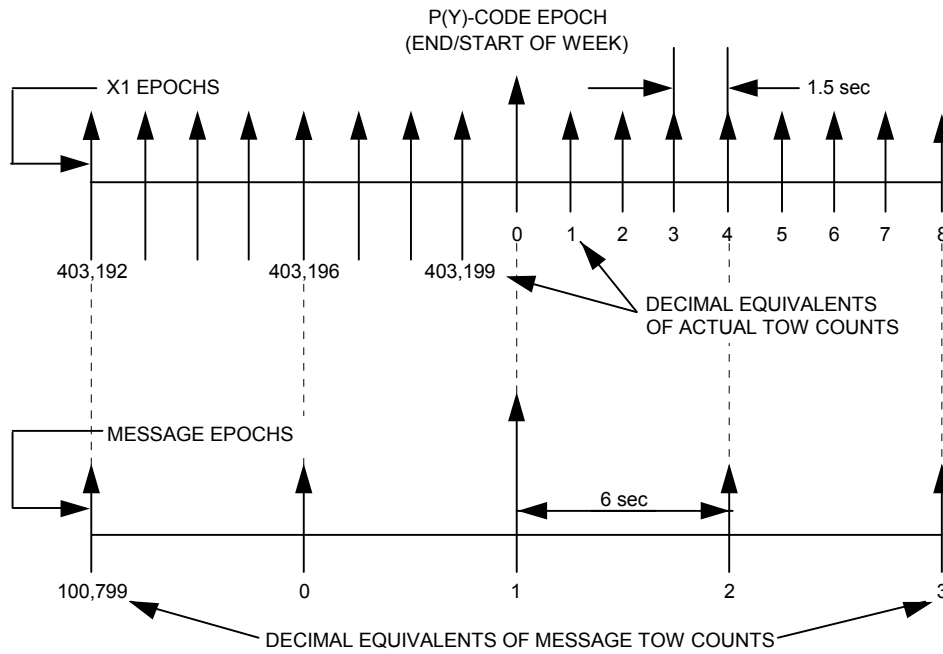

NOTES:

1. THE TOW COUNT APPEARS IN EACH 6-SECOND MESSAGE
2. THE 6-SECOND MESSAGE TOW COUNT CONSISTS OF THE 17 MSBs OF THE ACTUAL TOW COUNT AT THE START OF THE NEXT MESSAGE.
3. TO CONVERT FROM THE MESSAGE TOW COUNT TO THE ACTUAL TOW COUNT AT THE START OF THE NEXT MESSAGE, MULTIPLY BY FOUR.

Figure 3-9. Time Line Relationship of a Six-Second Message

4. NOT APPLICABLE

5. NOT APPLICABLE

6. NOTES

6.1 Acronyms

AFMC	-	Air Force Materiel Command
AFSPC	-	Air Force Space Command
ASCII	-	American Standard Code for Information Interchange
A-S		Anti-Spoof
bps	-	bits per second
BPSK	-	Bi-Phase Shift Key
C/A	-	Course/Acquisition
CDC	-	Clock Differential Correction
CNAV	-	Civil Navigation
CRC	-	Cyclic Redundancy Check
CS	-	Control Segment
dB	-	Decibel
<u>dBi</u>		<u>Decibels with respect to isotropic antenna</u>
dBW	-	Decibels with respect to 1 Watt
DC	-	Differential Correction
DoD	-	Department of Defense
ECEF	-	Earth-Centered, Earth-Fixed
ECI	-	Earth Centered Inertial
EDC	-	Ephemeris Differential Correction
EOL	-	End of Life
FEC	-	Forward Error Correction
GGTO	-	GPS/GNSS Time Offset
GNSS	-	Global Navigation Satellite System
GPS	-	Global Positioning System
<u>GPSW</u>		<u>Global Positioning System Wing</u>
Hz	-	Hertz
I5	-	Inphase Code on L5 Signal
ICC	-	Interface Control Contractor
ID	-	Identification
IODC	-	Issue of Data, Clock
IS	-	Interface Specification
ISC	-	Inter-Signal Correction
LSB	-	Least Significant Bit

MSB - Most Significant Bit
NAV - Navigation

NSI5	-	Non-Standard I-Code
NSQ5	-	Non-Standard Q-Code
OCS	-	Operational Control System
PIRN	-	Proposed Interface Revision Notice
PRN	-	Pseudo-Random Noise
P(Y)	-	Precise (Anti-Spoof) Code
Q5	-	Quadrature code on L5 Signal
RF	-	Radio Frequency
RHCP	-	Right Hand Circular Polarization
RMS	-	Root Mean Square
SBAS	-	Satellite Based Augmentation System
sps	-	Symbols per Second.
SIS	-	Signal In Space
SS	-	Space Segment
<u>SSV</u>		<u>Space Service Volume</u>
SV	-	Space Vehicle
TBD	-	To Be Determined
TBS	-	To Be Supplied
TOW	-	Time Of Week
URA	-	User Range Accuracy
US	-	User Segment
USNO	-	US Naval Observatory
UTC	-	Coordinated Universal Time
<u>WGS 84</u>	-	<u>World Geodetic System 1984</u>
WN	-	Week Number
WN _e	-	Extended Week Number

6.2 Definitions.

6.2.1 User Range Accuracy. See ~~paragraph~~ Section 6.2.1 of IS-GPS-200.

6.2.2 SV Block Definitions. The following block definitions are given to facilitate discussion regarding the capability of the various blocks of GPS satellites to support the SV-to-user interface.

6.2.2.1 Developmental SVs. See paragraph 6.2.2.1 of IS-GPS-200.

6.2.2.2 Operational SVs. The operational satellites are designated ~~Block II,~~ Block IIA, Block IIR, Block IIRM, Block IIF and Block III SVs. Characteristics of these SVs are provided below. These SVs transmit configuration codes as specified in paragraph 20.3.3.5.1.4 of IS-GPS-200. The navigation signal provides no direct indication of the type of the transmitting SV.

~~6.2.2.2.1 Block II SVs. See paragraph 6.2.2.2.1 of ISGPS 200. These satellites do not broadcast the L5 signal.~~

6.2.2.2.~~1~~² Block IIA SVs.- See paragraph 6.2.2.2.2 of IS-GPS-200. These satellites do not broadcast the L5 signal.

~~6.2.2.2.3~~ 6.2.2.2.2 Block IIR SVs. See paragraph 6.2.2.2.3 of IS-GPS-200. These satellites do not broadcast the L5 signal.

6.2.2.2.~~3~~⁴ Block IIR-M SVs. See paragraph 6.2.2.2.4 of IS-GPS-200. These satellites do not broadcast the L5 signal.

6.2.2.2.~~4~~⁵ Block IIF SVs. See paragraph 6.2.2.2.5 of IS-GPS-200. The IIF operational SVs do broadcast the L5 signal.

6.2.2.2.~~5~~⁶ Block III SVs. See paragraph 6.2.2.2.6 of IS-GPS-200. The III operational SVs do broadcast the L5 signal.

~~The block of operational planned SVs will be termed "Block III" SVs. The Block III operational SVs will broadcast the L5 signal.~~

6.2.3 Operational Interval Definitions. See paragraph 6.2.3 of IS-GPS-200. There is no requirement for extended operations on L5.

6.2.4 GPS Week Number. See paragraph 6.2.4 of IS-GPS-200 and paragraph 20.3.3.1.1.1.

6.3 Supporting Material.

6.3.1 L5 Received Signals. The guaranteed minimum user-received signal levels are defined in paragraph 3.3.1.6. Higher received signal levels can be caused by such factors as SV attitude errors, mechanical antenna alignment errors, transmitter power output variations resultant of temperature variations, voltage variations and power amplifier variations, and a variability in link atmospheric path loss. In addition and for the purpose of establishing GPS user receiver dynamic range, the maximum received signal level, as measured at the output of a 3 dBi linearly polarized receiver antenna, is not expected to exceed -150.0 dBW in each L5 signal channel.

6.3.2 Integrated Phase Noise Characteristics. As an aid to user equipment receiver designers, a plot is provided (Figure 6-1) of a typical GPS Block IIF phase noise spectral density for the un-modulated L5 carrier. [A plot of a typical GPS Block III phase noise spectral density will be added TBD.](#)

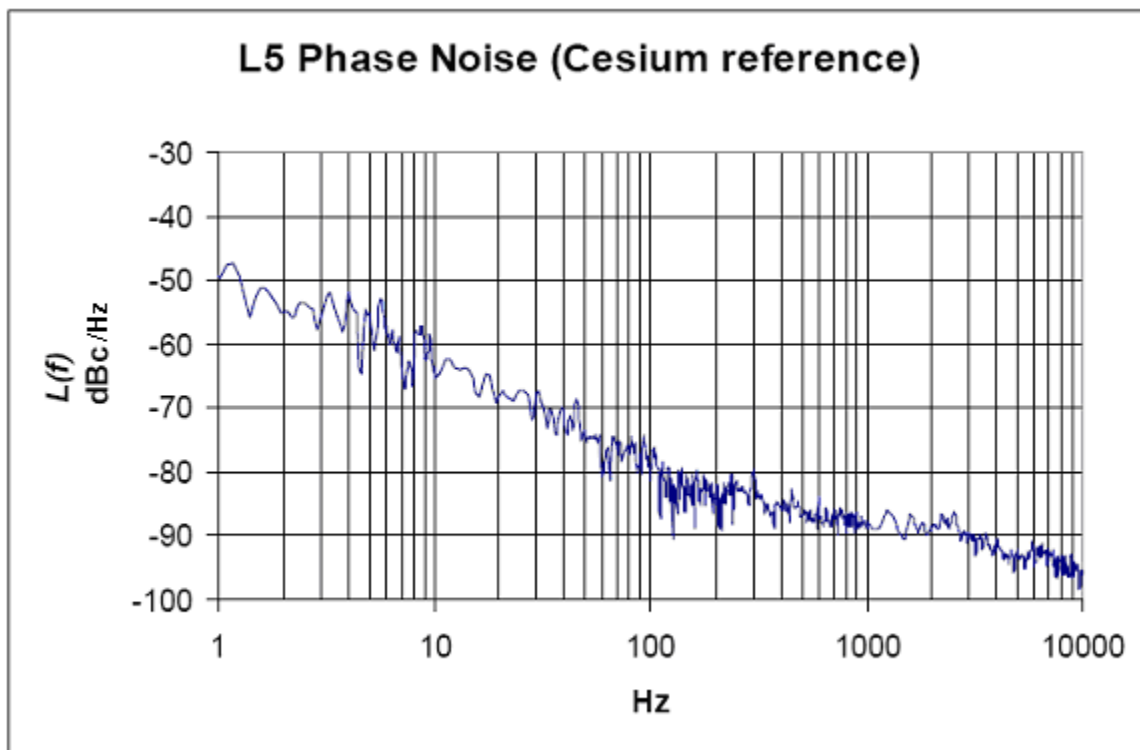

Figure 6-1. Carrier Phase Noise Spectral Density

6.3.3 Ellipticity Characteristics. As an aid to user equipment receiver designers, a table is provided (Table 6-I) of a typical GPS Block IIF ellipticity as a function of angular range. [A table of a typical GPS Block III ellipticity will be added TBD.](#)

Table 6-I. Typical Ellipticity vs Angular Range

Angle (deg)	±0	±2	±4	±6	±8	±10	±12	±14.3
Ellipticity (dB)	1.5	1.5	1.5	1.5	1.5	1.5	1.5	2.0

6.3.4 Additional PRN Sequences. Among all unique L5-code sequences that could be generated using different initial states as described in Section 3.2.1.1, 74 sequences (37 I5 and 37 Q5) are selected and assigned in Table 3-I. An additional 346 sequences (173 I5 and 173 Q5) are selected and assigned with PRN numbers in the below Table 6-II. Any assignment of an L5 PRN number and its code sequence for any additional SV and/or other L5 signal applications, such as Satellite Based Augmentation System (SBAS) satellite signals, will be selected from the sequences of Table 6-II.

Table 6-II. Additional Code Phase Assignments (sheet 1 of 6)				
PRN Signal No.*	XB Code Advance – Chips**		Initial XB Code State***	
	I5	Q5	I5	Q5
38	5358	4226	0101100000110	1111110011101
39	3550	5604	1001001100101	0101010011111
40	3412	6375	1100111001010	1000110101010
41	819	3056	0111011011001	0010111100100
42	4608	1772	0011101101100	1011000100000
43	3698	3662	0011011111010	0011001011001
44	962	4401	1001011010001	1000100101000
45	3001	5218	1001010111111	0000001111110
46	4441	2838	0111000111101	0000000010011
47	4937	6913	0000001000100	0101110011110
48	3717	1685	1000101010001	0001001000111
49	4730	1194	0011010001001	0011110000100
50	7291	6963	1000111110001	0100101011100
51	2279	5001	1011100101001	0010100011111
52	7613	6694	0100101011010	1101110011001
53	5723	991	0000001000010	0011111101111
54	7030	7489	0110001101110	1100100110111
55	1475	2441	0000011001110	1001001100110
56	2593	639	1110111011110	0100010011001
57	2904	2097	0001000010011	0000000001011
58	2056	2498	0000010100001	0000001101111
59	2757	6470	0100001100001	0101101101111
60	3756	2399	0100101001001	0100100001101
61	6205	242	0011110011110	1101100101011
62	5053	3768	1011000110001	1010111000100
63	6437	1186	0101111001011	0010001101001

- * PRN sequences 38 through 63 are reserved for GPS.
- ** XB Code Advance is the number of XB clock cycles beyond an initial state of all 1s.
- *** In the binary notation for the first 13 chips of the I5 and Q5 XB codes as shown in these columns. The rightmost bit is the first bit out. Since the initial state of the XA Code is all 1s, these first 13 chips are also the complement of the initial states of the I5 or Q5-codes.

NOTE: The code phase assignments constitute inseparable pairs, each consisting of a specific I5 and a specific Q5-code phase, as shown above.

Table 6-II. Additional Code Phase Assignments (sheet 2 of 6)

PRN Signal No.	XB Code Advance – Chips**		Initial XB Code State***	
	I5	Q5	I5	Q5
64	7789	5246	1000100010001	1001101001111
65	2311	4259	0001000101111	0001100100010
66	7432	5907	0001100111111	0000111111000
67	5155	3870	1010101100001	0011100100111
68	1593	3262	0101011111001	0000001010010
69	5841	7387	0101101100001	1100111111001
70	5014	3069	1000101111011	0111111110010
71	1545	2999	0111011001111	0101011111111
72	3016	7993	0001011011000	1100001111011
73	4875	7849	1110000111000	1110100110101
74	2119	4157	0111010010001	1010010110101
75	229	5031	0001101111000	0101111101111
76	7634	5986	1111001010100	1010110110010
77	1406	4833	1011101110100	1101110110001
78	4506	5739	0000100110000	1010000100100
79	1819	7846	1100010000111	0100110101010
80	7580	898	0001101111111	1000011100011
81	5446	2022	1100110101101	1100111011010
82	6053	7446	1101011001011	0010110001111
83	7958	6404	1100001101100	1101101110110
84	5267	155	1011110110001	1101111001001
85	2956	7862	0111010110101	1100100000000
86	3544	7795	1100101101101	1001101000100
87	1277	6121	1100111011111	1111011010001
88	2996	4840	1011111111011	0110101110111
89	1758	6585	1110100100111	0000100111111
90	3360	429	1111110010100	1101101001110
91	2718	6020	0101001111110	1100111001011
92	3754	200	0010100100101	1010111000011
93	7440	1664	0001111000011	1110110010110
94	2781	1499	1100111000000	1110100011111
95	6756	7298	1110010101000	0001101100011
96	7314	1305	0111000101001	0001011010110
97	208	7323	1111101010101	0000001000111
98	5252	7544	1010111001101	1010011000000
99	696	4438	1100101001011	1000111101101

** XB Code Advance is the number of XB clock cycles beyond an initial state of all 1s.

*** In the binary notation for the first 13 chips of the I5 and Q5 XB codes as shown in these columns. The rightmost bit is the first bit out. Since the initial state of the XA Code is all 1s, these first 13 chips are also the complement of the initial states of the I5 or Q5-codes.

NOTE: The code phase assignments constitute inseparable pairs, each consisting of a specific I5 and a specific Q5-code phase, as shown above.

Table 6-II. Additional Code Phase Assignments (sheet 3 of 6)

PRN Signal No.	XB Code Advance – Chips**		Initial XB Code State***	
	I5	Q5	I5	Q5
100	527	2485	0010100000110	1101101011100
101	1399	3387	1101000010001	1000010110011
102	5879	7319	0111011010011	0010001110001
103	6868	1853	1101110101111	0010100100110
104	217	5781	0111011011111	0100000111111
105	7681	1874	1010101001100	1000001111101
106	3788	7555	1011010000011	1010101111010
107	1337	2132	0101100000000	1111010101010
108	2424	6441	0000111101000	1101010111100
109	4243	6722	0110000111011	1111100001010
110	5686	1192	1101100100000	1111000010001
111	1955	2588	0011011101111	1101111011101
112	4791	2188	1001111101100	0010000100001
113	492	297	0100011000110	1100100111100
114	1518	1540	0111000101110	1100111100011
115	6566	4138	0100010110000	1001100001111
116	5349	5231	0110111100100	1110011001001
117	506	4789	0001110010010	0111110110011
118	113	659	1110110110101	1111011010110
119	1953	871	1101110111100	1000111011110
120	2797	6837	1101001100010	1101001011001
121	934	1393	1100011001100	0010001111001
122	3023	7383	1000011000101	1111110011111
123	3632	611	1111011011011	1000110000001
124	1330	4920	0000001100100	0000111100011
125	4909	5416	1101110000101	0111011011100
126	4867	1611	1100001000010	0101101010100
127	1183	2474	0001101001101	0000101010111
128	3990	118	1010100101011	1010111101101
129	6217	1382	1111011110100	0100010000010

** XB Code Advance is the number of XB clock cycles beyond an initial state of all 1s.

*** In the binary notation for the first 13 chips of the I5 and Q5 XB codes as shown in these columns. The rightmost bit is the first bit out. Since the initial state of the XA Code is all 1s, these first 13 chips are also the complement of the initial states of the I5 or Q5-codes.

NOTE: The code phase assignments constitute inseparable pairs, each consisting of a specific I5 and a specific Q5-code phase, as shown above.

Table 6-II. Additional Code Phase Assignments (sheet 4 of 6)

PRN Signal No.	XB Code Advance – Chips**		Initial XB Code State***	
	I5	Q5	I5	Q5
130	1224	1092	111111101100	101011101111
131	1733	7950	0000010000111	0110001000010
132	2319	7223	1111110000010	1011000011010
133	3928	1769	0011100111011	1000100000111
134	2380	4721	1101100010101	1001011110110
135	841	1252	0101011111011	1000001011000
136	5049	5147	0001100011011	0000110010111
137	7027	2165	0001101110111	0010101101011
138	1197	7897	1110011110000	0011100001100
139	7208	4054	0111100011111	0100011001011
140	8000	3498	0011101110000	1010101001111
141	152	6571	1111001001000	0100001000101
142	6762	2858	0001101110010	0000001111100
143	3745	8126	0101100111100	1101001110111
144	4723	7017	0010010111101	1110111110001
145	5502	1901	1101110110011	1110111010001
146	4796	181	0011110011111	0001010110011
147	123	1114	1001010101111	0111111000101
148	8142	5195	0111111101111	0100010011100
149	5091	7479	0000100100001	1110000010011
150	7875	4186	1110001101011	0110010101000
151	330	3904	1111010010001	0000100000100
152	5272	7128	1011010111101	0100100101011
153	47912	1396	0001101110000	1000010001111
154	374	4513	0000010111100	1110101000010
155	2045	5967	0100101111100	1110000111011
156	6616	2580	1110110111010	1110110010010
157	6321	2575	1101110101011	1001001001000
158	7605	7961	1101000110001	0011100001101
159	2570	2598	0100100010100	0000111101110

** XB Code Advance is the number of XB clock cycles beyond an initial state of all 1s.

*** In the binary notation for the first 13 chips of the I5 and Q5 XB codes as shown in these columns. The rightmost bit is the first bit out. Since the initial state of the XA Code is all 1s, these first 13 chips are also the complement of the initial states of the I5 or Q5-codes.

NOTE: The code phase assignments constitute inseparable pairs, each consisting of a specific I5 and a specific Q5-code phase, as shown above.

Table 6-II. Additional Code Phase Assignments (sheet 5 of 6)

PRN Signal No.	XB Code Advance – Chips**		Initial XB Code State***	
	I5	Q5	I5	Q5
160	2419	4508	1110100011001	0100001001100
161	1234	2090	1101000100111	0010111011110
162	1922	3685	0101101110111	0110011011010
163	4317	7748	0010111010000	1101011000010
164	5110	684	0000111011000	1100010001101
165	825	913	1001110111011	1010111011001
166	958	5558	0110100011111	0100001001010
167	1089	2894	0111011111100	0111000111010
168	7813	5858	1010010011010	0000000110000
169	6058	6432	0010011010110	1100101111100
170	7703	3813	0111100110011	0001100100111
171	6702	3573	0000011011011	0011010111001
172	1714	7523	1001010011010	0001000011100
173	6371	5280	1101010101111	1100101010110
174	2281	3376	1110111001010	1101110010010
175	1986	7424	0010011110110	1111111111001
176	6282	2918	0011110101001	0110000001010
177	3201	5793	1111010000111	0100101001010
178	3760	1747	0010010010100	1111110100100
179	1056	7079	0100101110010	1100010101011
180	6233	2921	1101110110000	1100110000001
181	1150	2490	1000111111011	0111111011010
182	2823	4119	0101101110000	0111000011101
183	6250	3373	0001110101011	1110010010110
184	645	977	1111000100010	0011111111000
185	2401	681	0101001000011	0010001101101
186	1639	4273	0011101111100	0001100110011
187	2946	5419	1011010111010	0100111011011
188	7091	5626	0000001010011	0110111000101
189	923	1266	0010011111101	1101011100011

** XB Code Advance is the number of XB clock cycles beyond an initial state of all 1s.

*** In the binary notation for the first 13 chips of the I5 and Q5 XB codes as shown in these columns. The rightmost bit is the first bit out. Since the initial state of the XA Code is all 1s, these first 13 chips are also the complement of the initial states of the I5 or Q5-codes.

NOTE: The code phase assignments constitute inseparable pairs, each consisting of a specific I5 and a specific Q5-code phase, as shown above.

Table 6-II. Additional Code Phase Assignments (sheet 6 of 6)

PRN Signal No.	XB Code Advance – Chips**		Initial XB Code State***	
	I5	Q5	I5	Q5
190	7045	5804	1111100011000	1001110110001
191	6493	2414	1101101101100	0001100110110
192	1706	6444	1101010010110	1101101010111
193	5836	4757	0110000101110	1001110000111
194	926	427	0110010011111	0110100111010
195	6086	5452	1000111001100	0110001100110
196	950	5182	1111101110001	0000100001100
197	5905	6606	0011111100001	0101000101101
198	3240	6531	0000001110001	1000001010111
199	6675	4268	1010110100100	0011001110001
200	3197	3115	0100001110110	0100011100110
201	1555	6835	0111110100011	0100101100101
202	3589	862	0001111001011	1110001010111
203	4555	4856	1010100011011	1010110110100
204	5671	2765	1001101110011	1111101101000
205	6948	37	0010111000001	1000001110100
206	4664	1943	1101100001111	1000010101100
207	2086	7977	1110111101001	1100001001101
208	5950	2512	0110110101101	1111111000011
209	5521	4451	0111110110010	0001011110011
210	1515	4071	1000101110111	1001000100001

** XB Code Advance is the number of XB clock cycles beyond an initial state of all 1s.
 *** In the binary notation for the first 13 chips of the I5 and Q5 XB codes as shown in these columns. The rightmost bit is the first bit out. Since the initial state of the XA Code is all 1s, these first 13 chips are also the complement of the initial states of the I5 or Q5-codes.

NOTE: The code phase assignments constitute inseparable pairs, each consisting of a specific I5 and a specific Q5-code phase, as shown above.

~~(This page intentionally left blank.)~~

10. APPENDIX I. LETTERS OF EXCEPTION

10.1 Scope. Approval of this document, as well as approval of any subsequent changes to the document, can be contingent upon a "letter of exception." This appendix depicts such "letters of exception" when authorized by the [GPS-JPOGPSW](#).

10.2 Applicable Documents. The documents listed in Section 2.0 shall be applicable to this appendix.

10.3 Letters of Exception. Any letter of exception which is in force for the revision of the IS is depicted in Figure 10-1.

(This page intentionally left blank.)

The Boeing Company
 5301 Bolsa Avenue
 Huntington Beach, CA 92647

December 6, 2004
 AFSS-GPSIIF-K211-JMH-04-0717

Headquarters, Space and Missile (SMC)
 SMC/GPK
 2420 Vela Way, Suite 1467
 El Segundo, CA 90245-4659



Dear Ms. Brown:

Subject: F04701-96-C-0025; Global Positioning System (GPS)
 Block III-Disposition of IRN-705-001

Reference: (a) Email from S. Colatti/Boeing to Felicia Brown and Lt. Kevin
 Reyes/AF on November 22, 2004
 (b) PCOL 04-085 letter dated November 02, 2004

Per the Referenced (a) email, Boeing provided its assessment of both cost and schedule impact to the latest IRN version (November 11, 2004). Boeing has reviewed the IRN-705-001 per the Referenced (b) letter. Please note that our review was based upon the receipt of the IRN versus the PIRN. The content of this document that has been determined out of scope of the Boeing contractual baseline is listed below:

Boeing has reviewed IRN-705-001 per the original direction of the Referenced (b) letter. The content of this document that has been determined out of scope of the Boeing contractual baseline is listed below:

IRN-705-001

Location	Exception	Rationale for Exception	Cost Impact	Schedule Impact
20.3.3 Page 44	New L5 CNAV	L5 CNAV Message 31 requires change to UG, Pred, UCD and possible generation of raw data.	High	High
20.3.3 Page 45	New L5 CNAV Messages	L5 CNAV Message 32 requires change to UG, Pred, UCD and possible generation of raw data.	High	High
20.3.3 Page 47	New L5 CNAV Messages	L5 CNAV Message 34 requires change to UG, Pred, UCD and possible generation of raw data.	High	High

Figure 10-1. Letters of Exception

ARSS-GPSIIF-K211-JMH-04-0717
 Headquarters, Space and Missile (SMC)
 Page 2 of 2



20.3.3 Page 48	New L5 CNAV Messages	L5 CNAV Message 35 requires change to UG, Pred, UCD and possible generation of raw data.	High	High
20.3.3 Page 49	New L5 CNAV Messages	L5 CNAV Message 36 requires change to UG, Pred, UCD and possible generation of raw data.	High	High
20.3.3 Page 50	New L5 CNAV Messages	L5 CNAV Message 37 requires change to UG, Pred, UCD and possible generation of raw data.	High	High
20.3.3 Page 52	New L5 CNAV Messages	L5 CNAV Message 13 requires change to UG, Pred, UCD and possible generation of raw data.	High	High
20.3.3 Page 53	New L5 CNAV Messages	L5 CNAV Message 14 requires change to UG, Pred, UCD and possible generation of raw data.	High	High
20.3.3 Page 54	New L5 CNAV Messages	L5 CNAV Message 15 requires change to UG, Pred, UCD and possible generation of raw data.	High	High

For purposes of this assessment, a High Impact to cost is defined as greater than \$250,000.

Should you require any additional information please contact the undersigned at telephone (714) 896-2561.

Sincerely,

J. M. Hughes
 Sr. Manager - Contracts & Pricing
 GPS IIF Program
 Air Force Space Systems
 M/C: H011-B145

JMH:jmh

Figure 10-1. Letters of Exception

20 APPENDIX II. GPS NAVIGATION DATA STRUCTURE FOR L5 CNAV DATA, D5(t)

20.1 Scope. This appendix describes the specific GPS L5 civil navigation (CNAV) data structure denoted by, D5(t).

20.2 Applicable Documents.

~~20.2.1~~ 20.2.1 Government Documents.

In addition to the documents listed in paragraph 2.1, the following documents of the issue specified contribute to the definition of the CNAV data related interfaces and form a part of this Appendix to the extent specified herein.

Specifications

None

Standards

None

Other Publications

None

20.2.2 Non-Government Documents.

In addition to the documents listed in paragraph 2.2, the following documents of the issue specified contribute to the definition of the CNAV data related interfaces and form a part of this Appendix to the extent specified herein.

Specifications

None

Other Publications

None

20.3 Requirements.

20.3.1 Data Characteristics. The L5 channel data stream mostly contains the same data as the L2 C channel. The data stream shall be transmitted by the SV on the L5 channel at the rate of 50 bps with rate 1/2 FEC resulting in 100 sps.

20.3.2 Message Structure. As shown in Figures 20-1 through 20-14, the L5 CNAV message structure utilizes a basic format of six-second 300-bit long messages. Each message contains a Cyclic Redundancy Check (CRC) parity block consisting of 24 bits covering the entire six-second message (300 bits) (reference Section 20.3.5).

Message type 0 (zero) is defined to be the default message. In the event of message generation failure, the SV shall replace each affected message type with the default message type. In the event that a particular message is not assigned (by the CS) a particular message type for broadcast, the SV shall generate and broadcast the default message type in that message slot.

Currently undefined and unused message types are reserved for future use.

20.3.3 Message Content. Each message starts with an 8-bit preamble – 10001011, followed by a 6-bit PRN number of the transmitting SV, a 6-bit message type ID, with a range of 0 (000000) to 63 (111111), and the 17-bit message Time of Week (TOW) count. When the value of the message TOW count is multiplied by 6, it represents SV time in seconds at the start of the next 6-second message. An “alert” flag, when raised (bit 38 = “1”), indicates to the user that the SV User Range Accuracy (URA) and/or the SV User Differential Range Accuracy (UDRA) may be worse than indicated in the respective message types, ~~and the SV should be used at the user’s own risk~~. For each default message (Message Type 0), bits 39 through 276 shall be alternating ones and zeros and the message shall contain a proper CRC parity block.

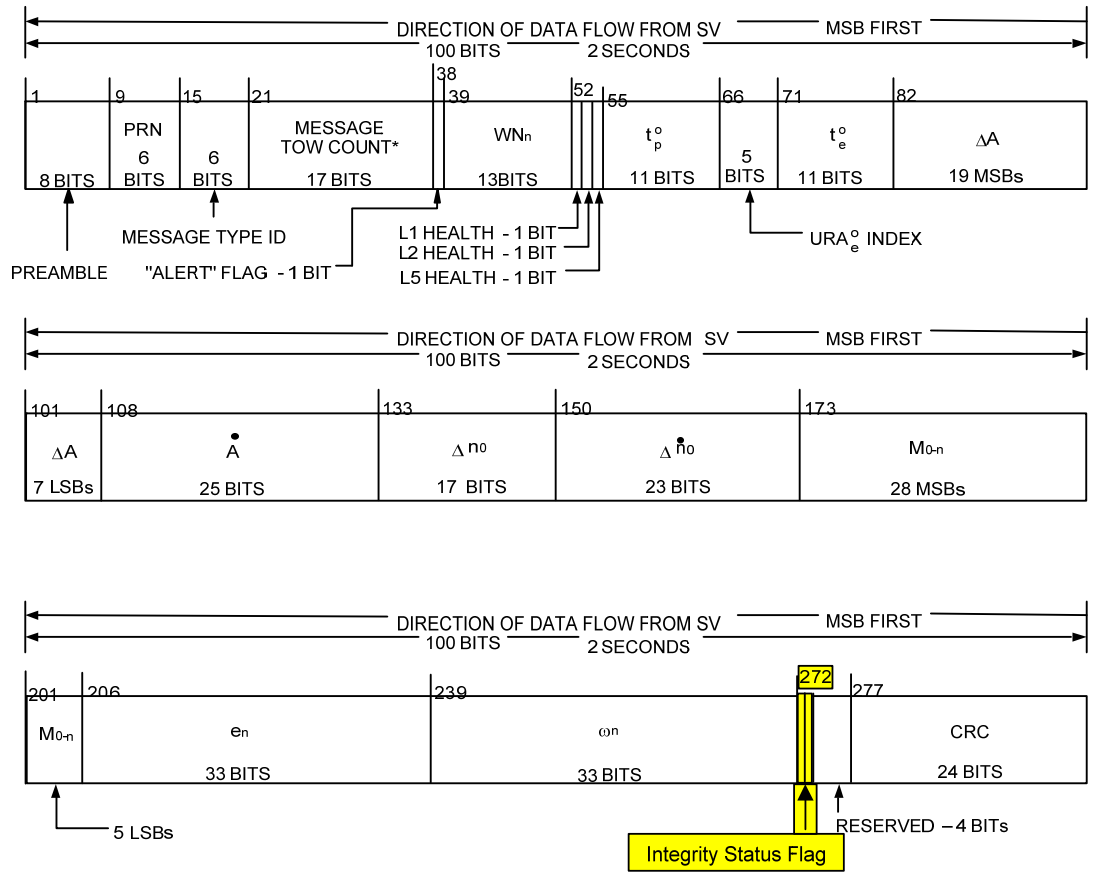

* MESSAGE TOW COUNT = 17 MSB OF ACTUAL TOW COUNT AT START OF NEXT 6-SECOND MESSAGE

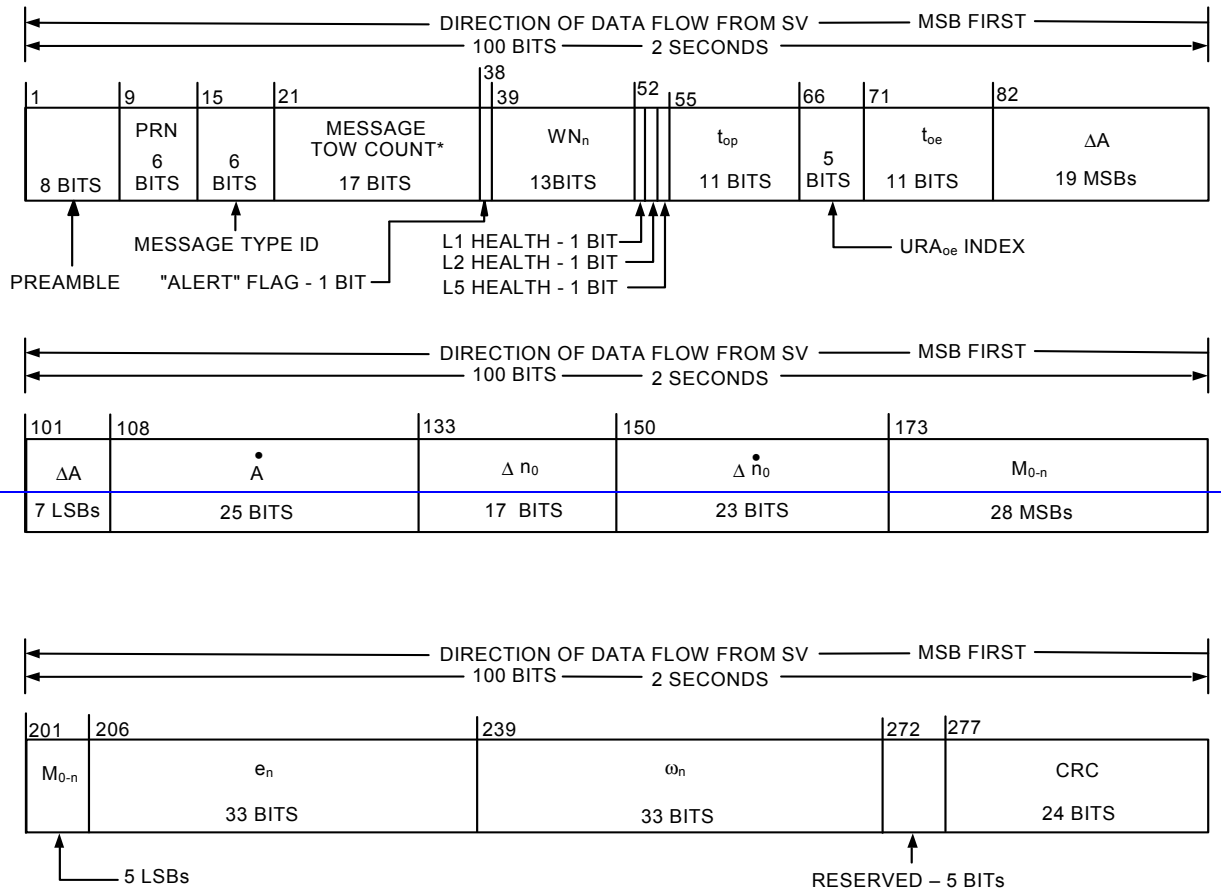

* MESSAGE TOW COUNT = 17 MSB OF ACTUAL TOW COUNT AT START OF NEXT 6-SECOND MESSAGE

Figure 20-1. Message type 10 - Ephemeris 1

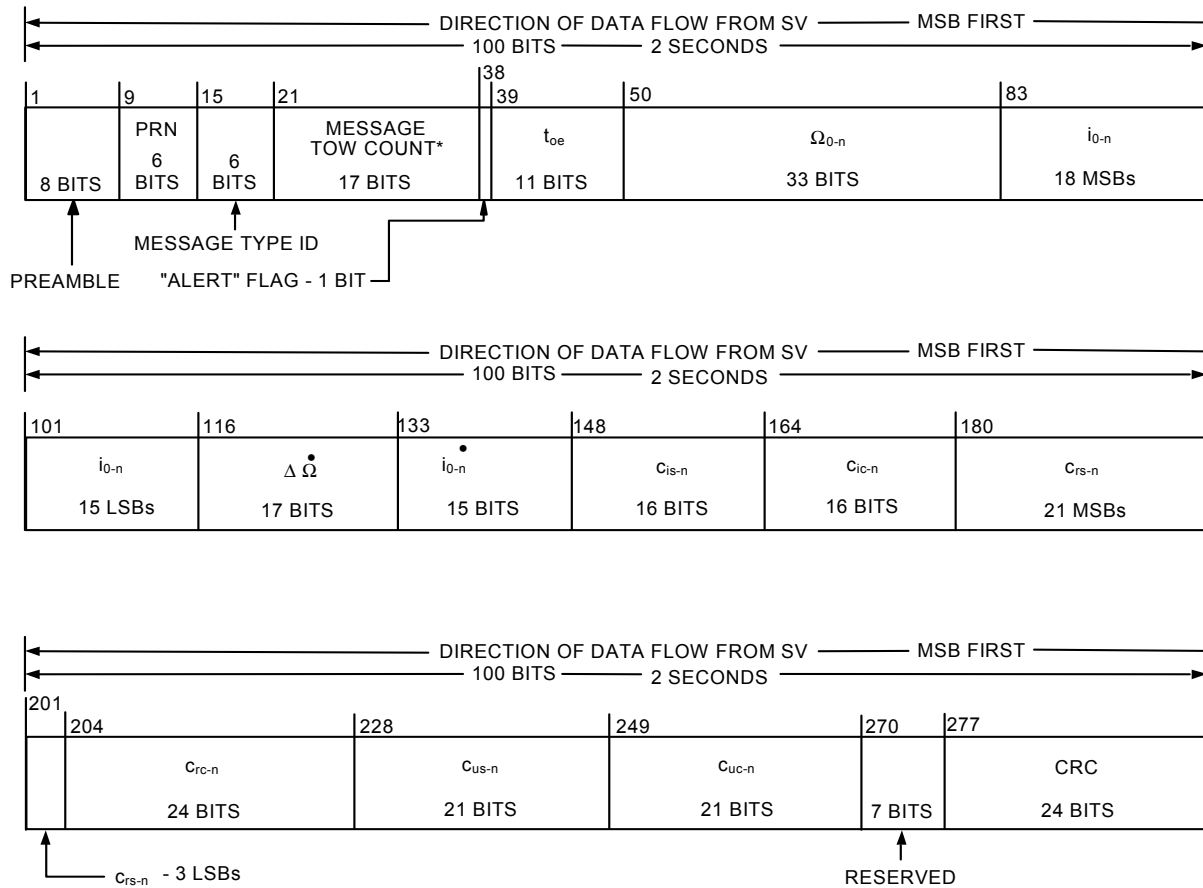

* MESSAGE TOW COUNT = 17 MSB OF ACTUAL TOW COUNT AT START OF NEXT 6-SECOND MESSAGE

Figure 20-2. Message type 11 - Ephemeris 2

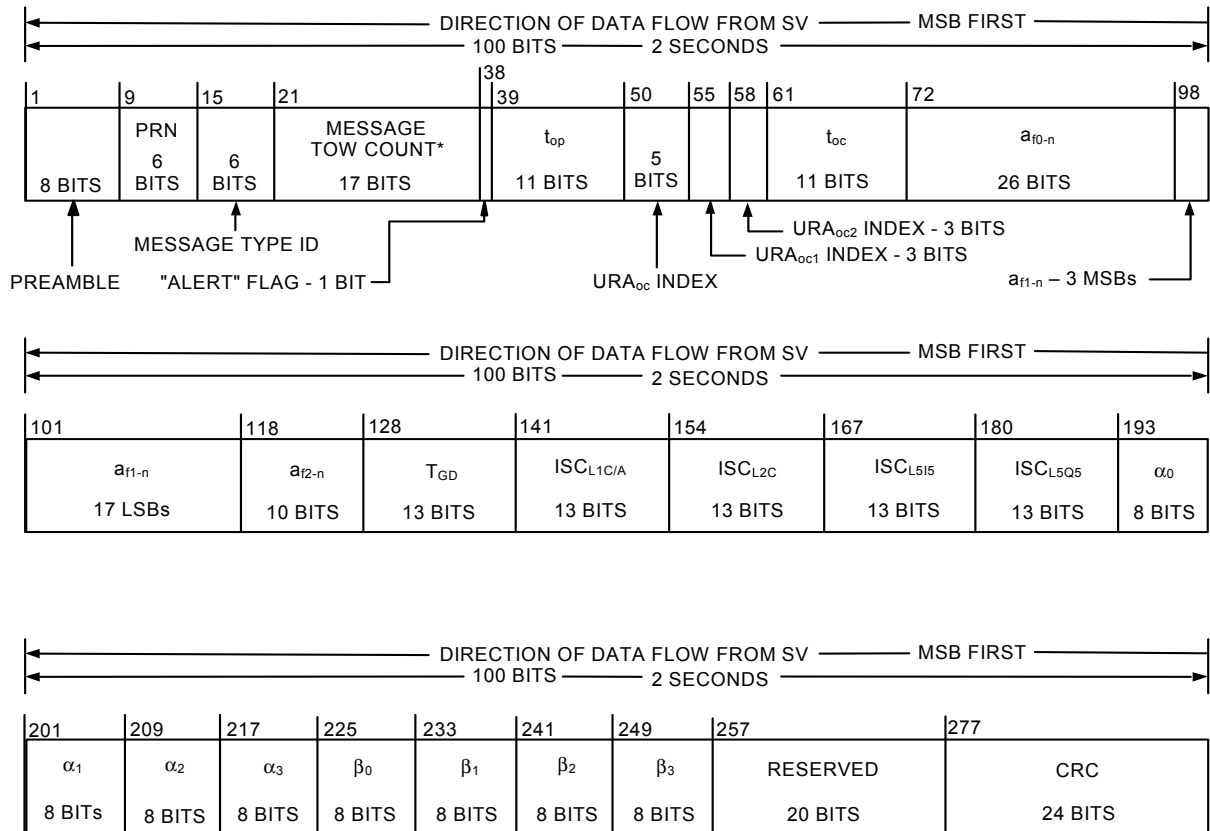

* MESSAGE TOW COUNT = 17 MSB OF ACTUAL TOW COUNT AT START OF NEXT 6-SECOND MESSAGE

Figure 20-3. Message type 30 - Clock, IONO & Group Delay

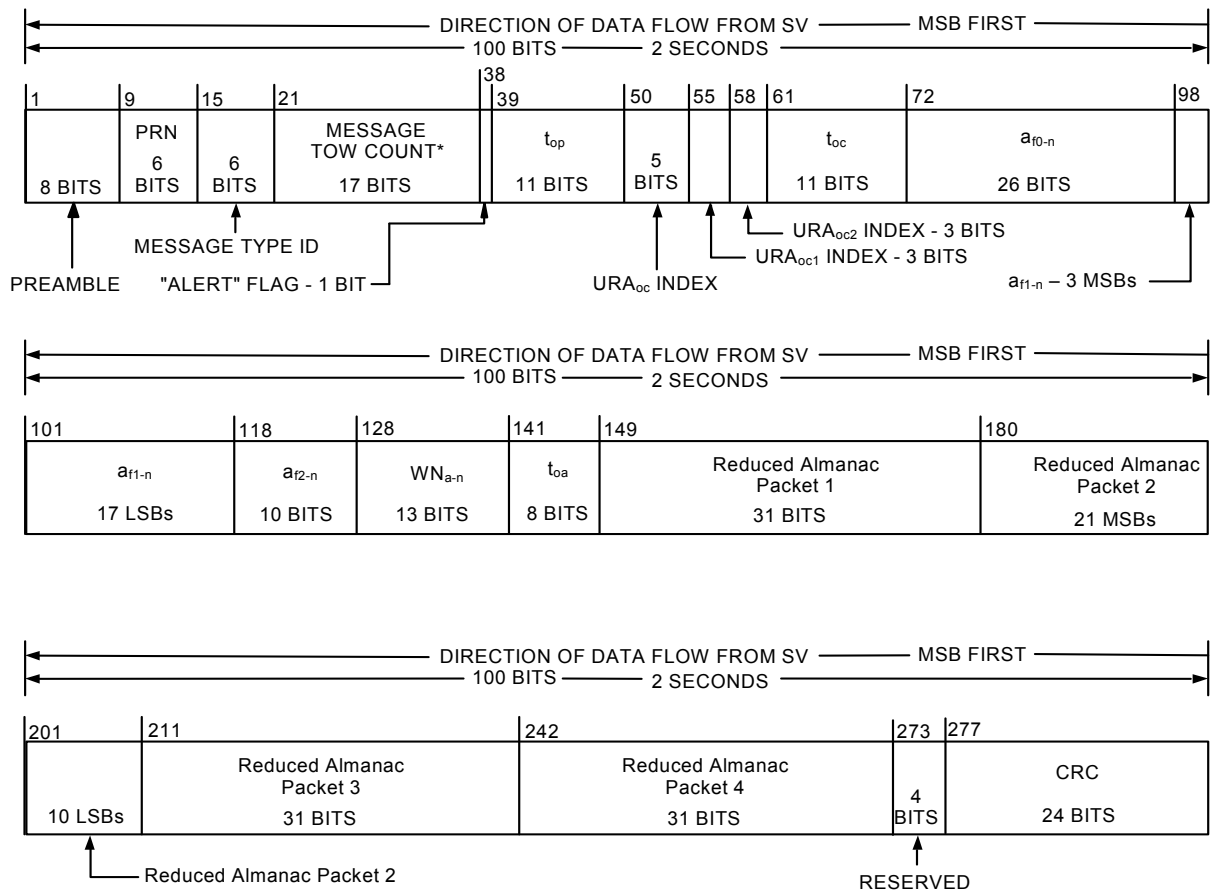

* MESSAGE TOW COUNT = 17 MSB OF ACTUAL TOW COUNT AT START OF NEXT 6-SECOND MESSAGE

Figure 20-4. Message type 31 - Clock & Reduced Almanac

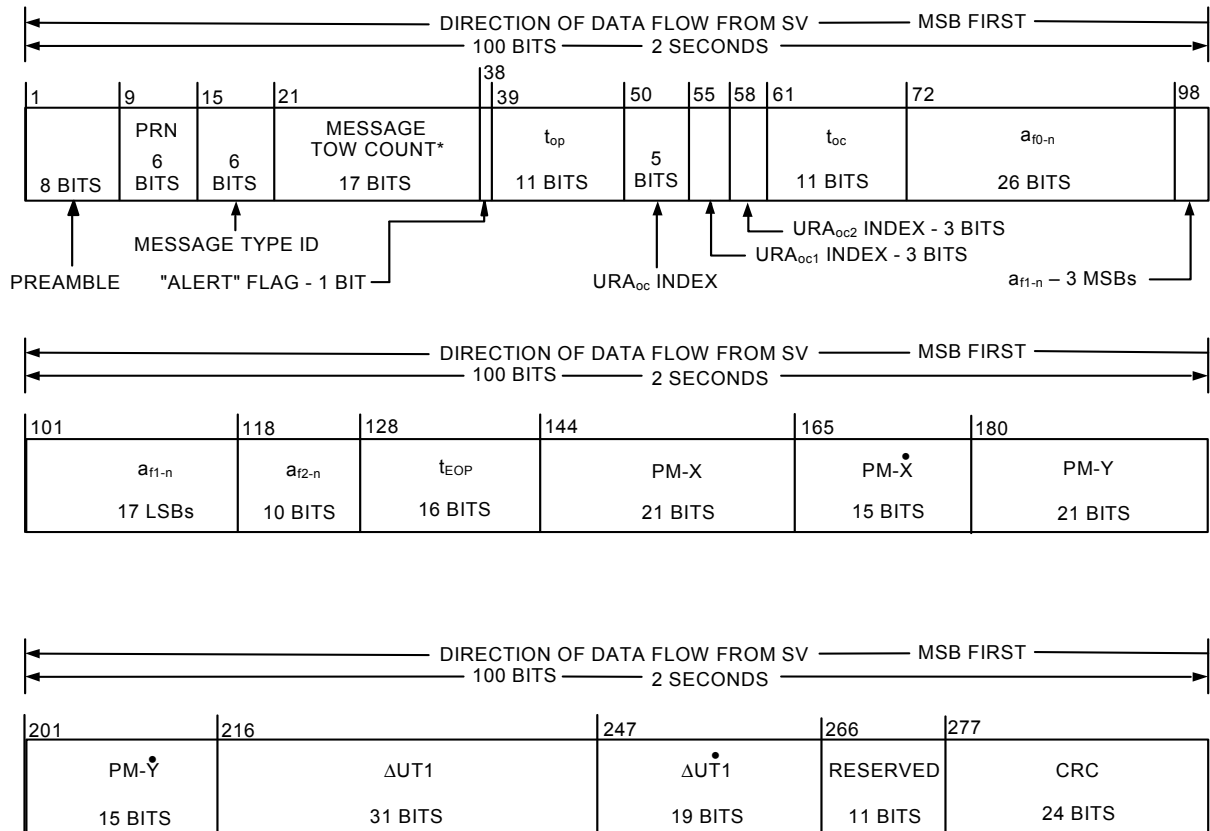

* MESSAGE TOW COUNT = 17 MSB OF ACTUAL TOW COUNT AT START OF NEXT 6-SECOND MESSAGE

Figure 20-5. Message type 32 - Clock & EOP

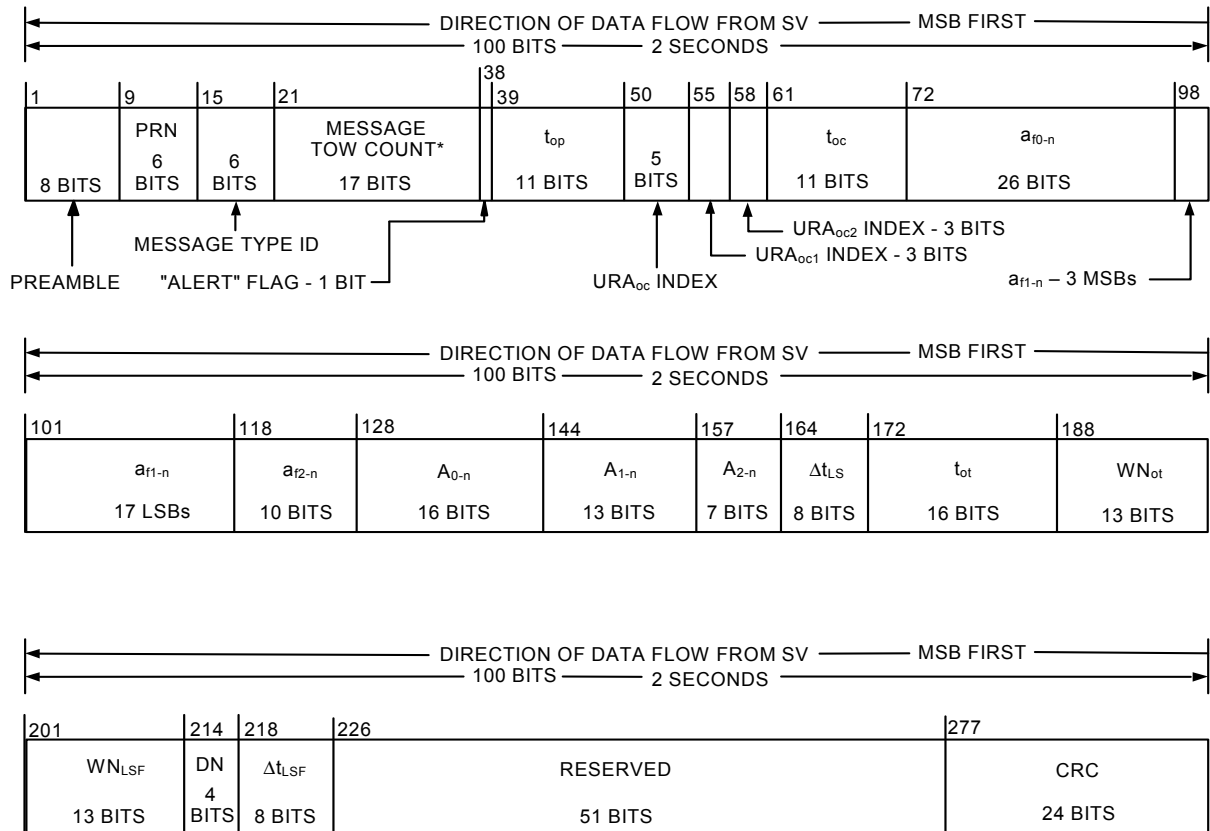

* MESSAGE TOW COUNT = 17 MSB OF ACTUAL TOW COUNT AT START OF NEXT 6-SECOND MESSAGE

Figure 20-6. Message type 33 - Clock & UTC

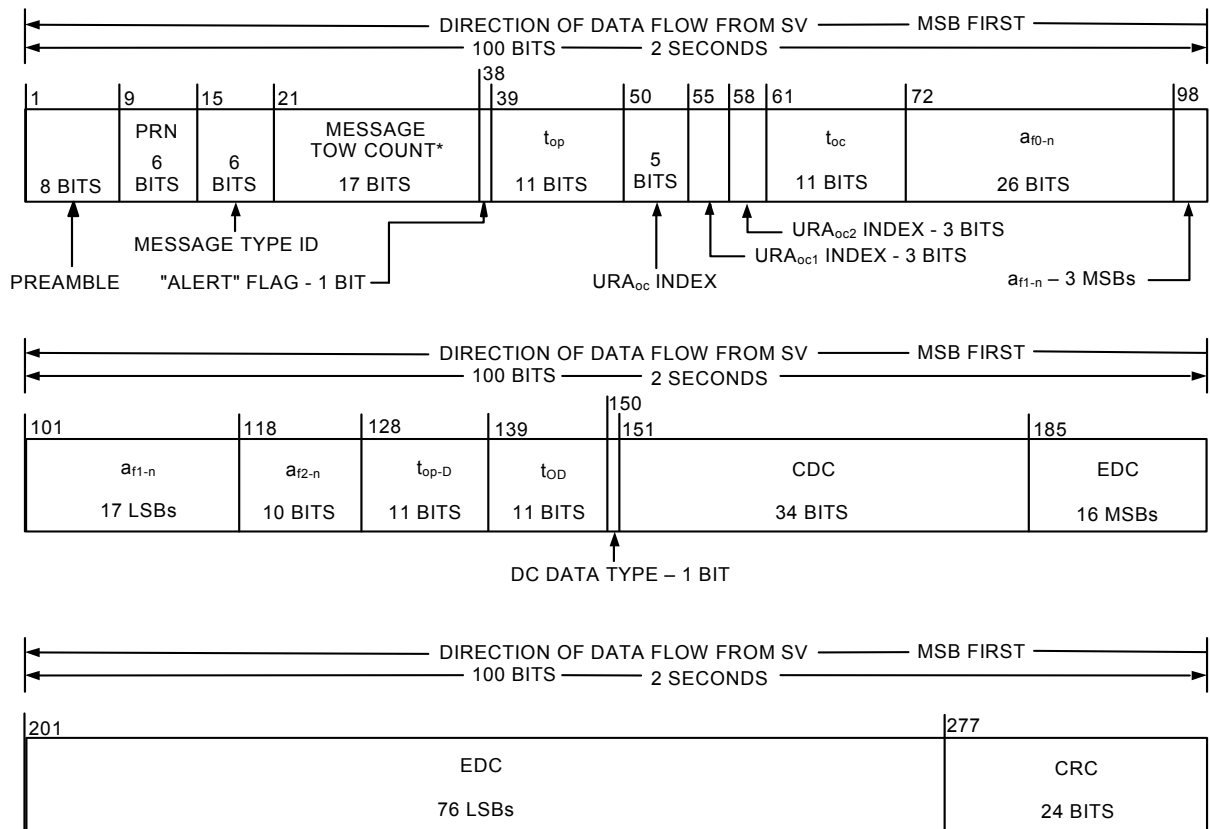

* MESSAGE TOW COUNT = 17 MSB OF ACTUAL TOW COUNT AT START OF NEXT 6-SECOND MESSAGE

CDC = Clock Differential Correction
 EDC = Ephemeris Differential Correction

Figure 20-7. Message type 34 - Clock & Differential Correction

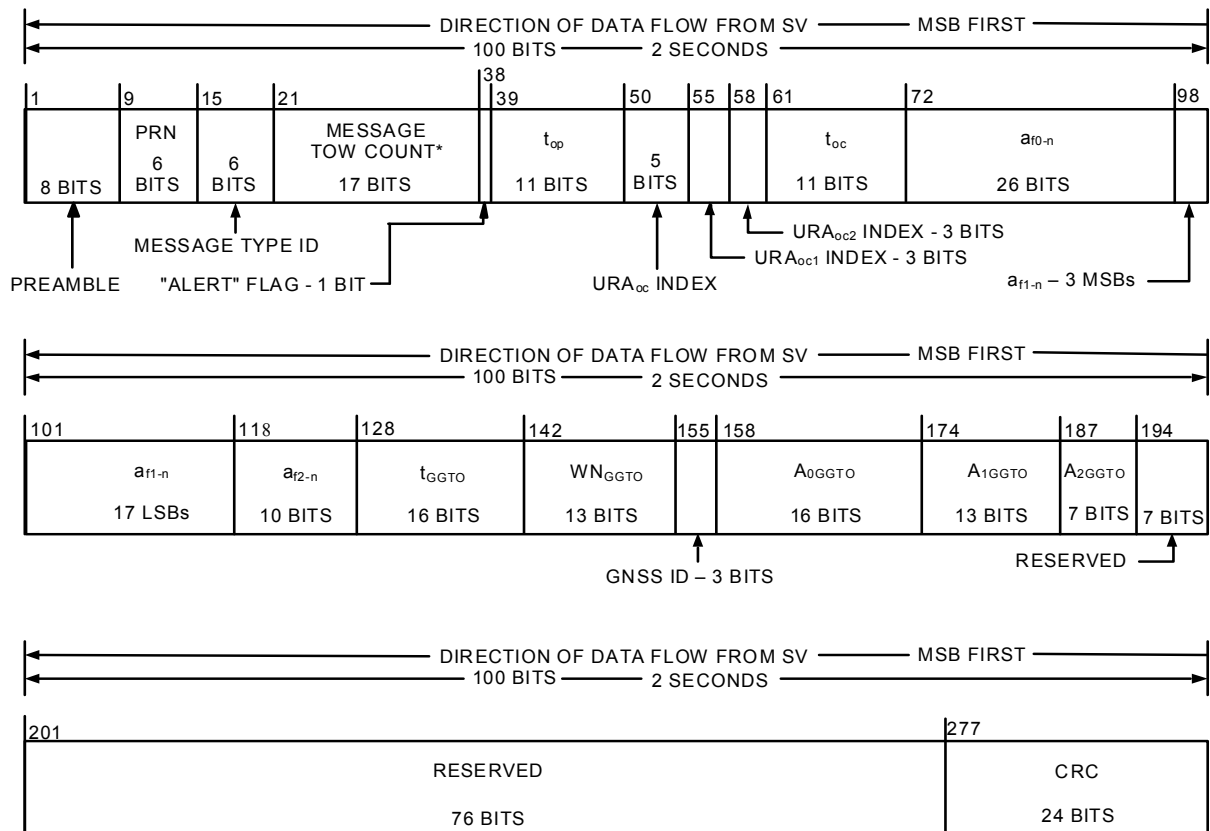

* MESSAGE TOW COUNT = 17 MSB OF ACTUAL TOW COUNT AT START OF NEXT 6-SECOND MESSAGE

Figure 20-8. Message type 35 - Clock & GGTO

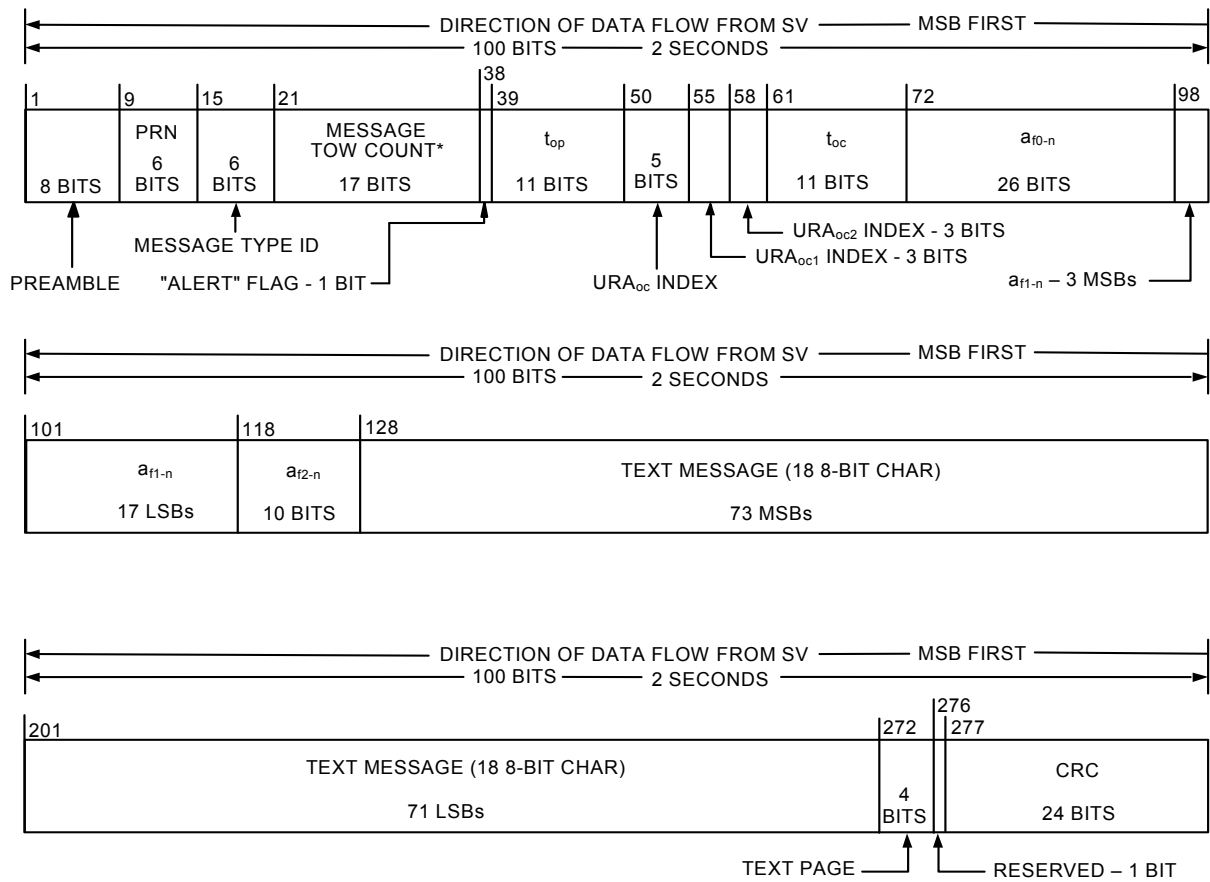

* MESSAGE TOW COUNT = 17 MSBs OF ACTUAL TOW COUNT AT START OF NEXT 6-SECOND MESSAGE

Figure 20-9. Message type 36 - Clock & Text

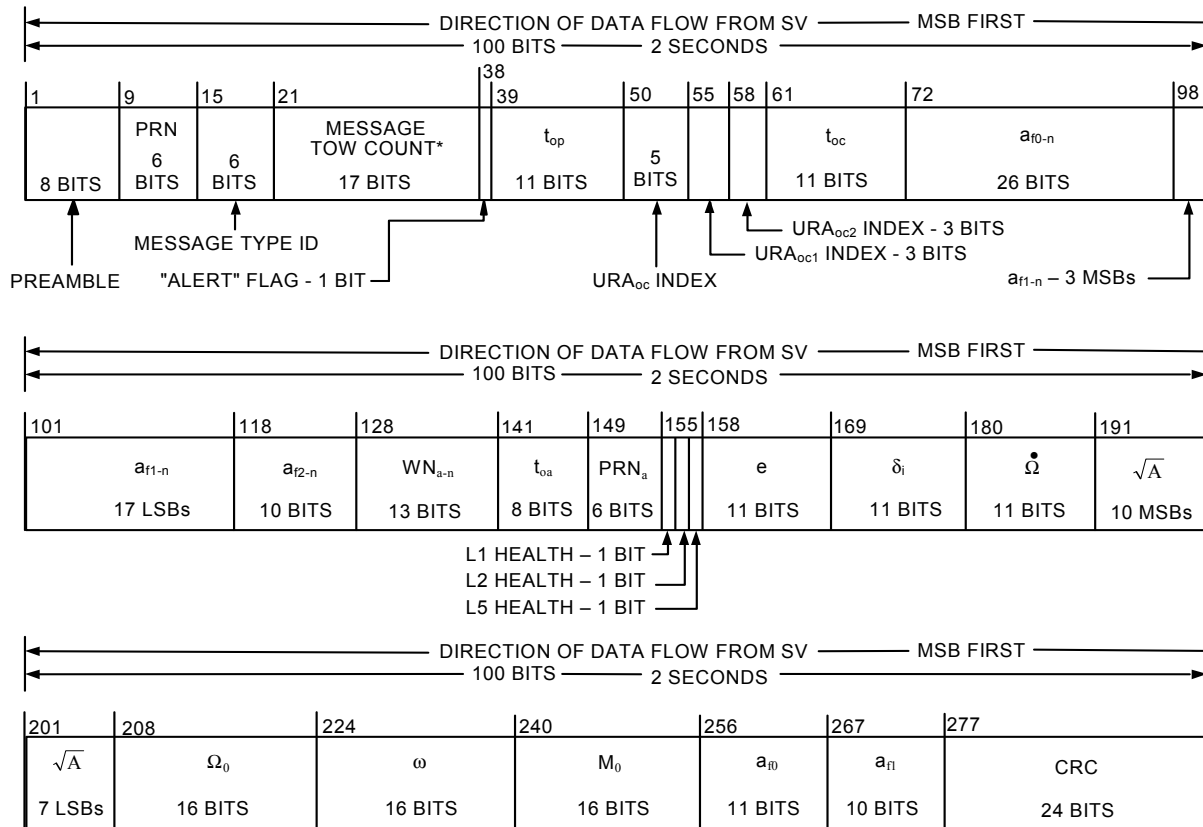

* MESSAGE TOW COUNT = 17 MSBs OF ACTUAL TOW COUNT AT START OF NEXT 6-SECOND MESSAGE

Figure 20-10. Message Type 37 - Clock & Midi Almanac

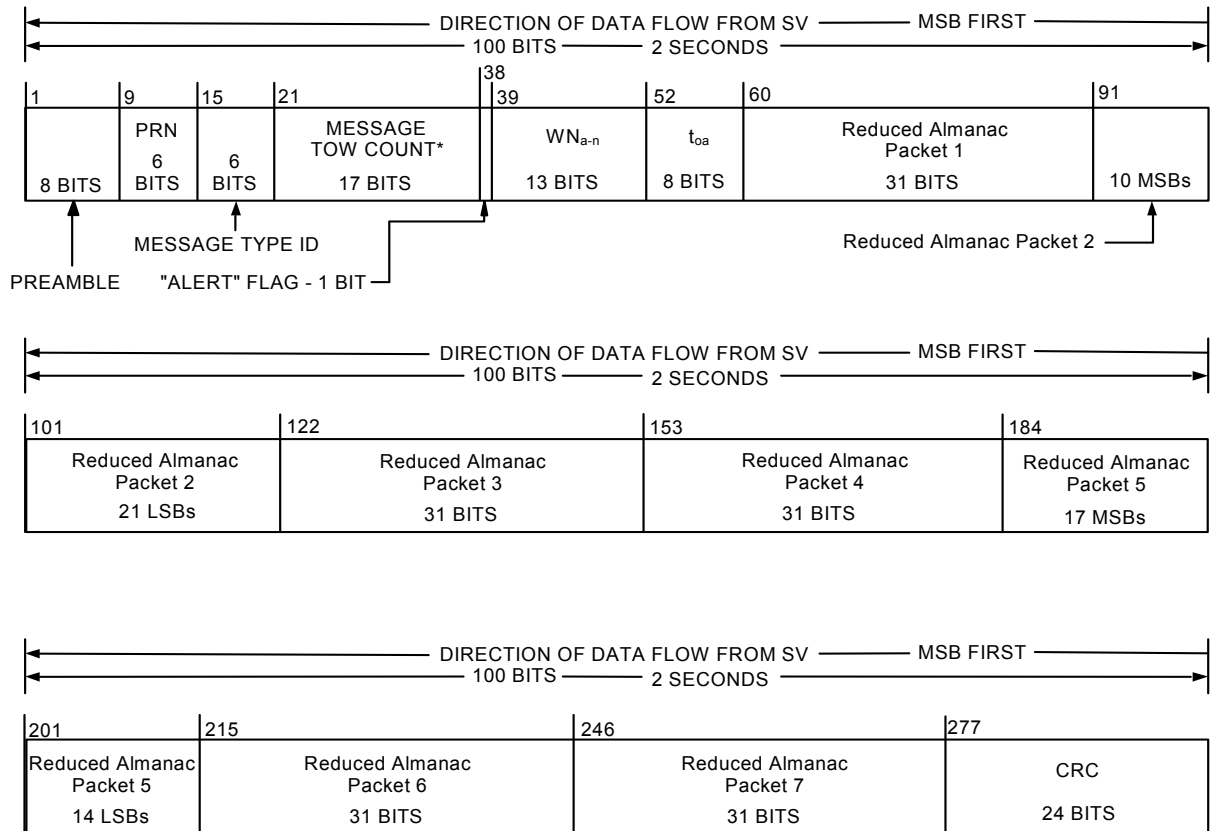

* MESSAGE TOW COUNT = 17 MSBs OF ACTUAL TOW COUNT AT START OF NEXT 6-SECOND MESSAGE

Figure 20-11. Message type 12 -Reduced Almanac

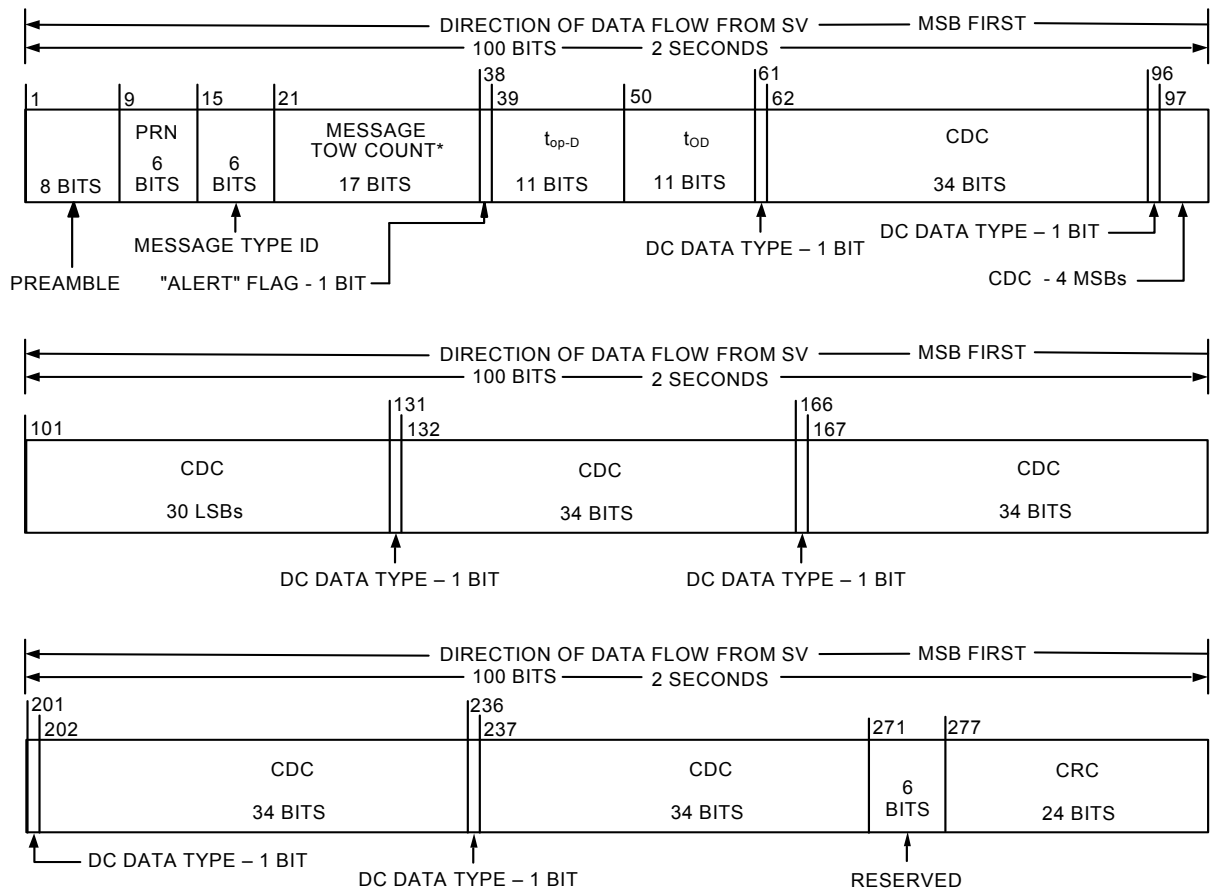

* MESSAGE TOW COUNT = 17 MSBs OF ACTUAL TOW COUNT AT START OF NEXT 6-SECOND MESSAGE

CDC = Clock Differential Correction

Figure 20-12. Message type 13 - Clock Differential Correction

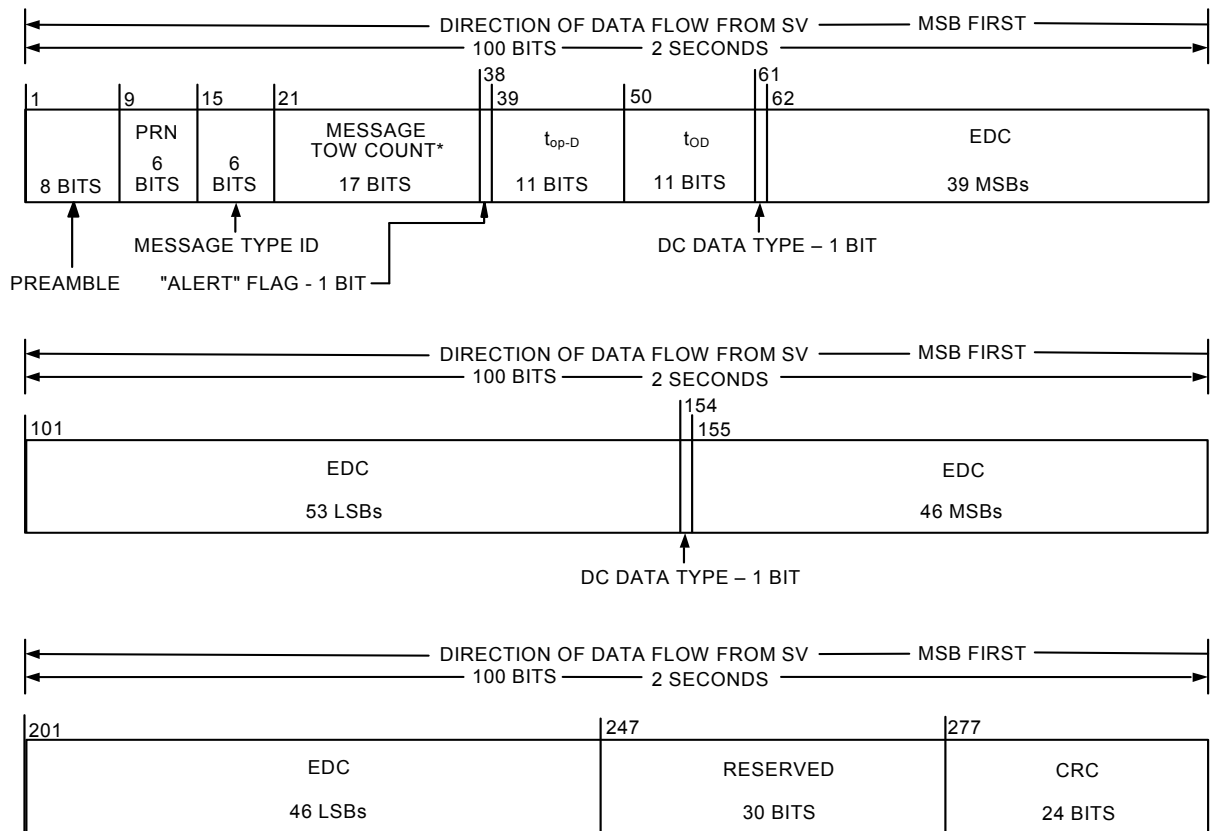

* MESSAGE TOW COUNT = 17 MSBs OF ACTUAL TOW COUNT AT START OF NEXT 6-SECOND MESSAGE

EDC = Ephemeris Differential Correction

Figure 20-13. Message type 14 - Ephemeris Differential Correction

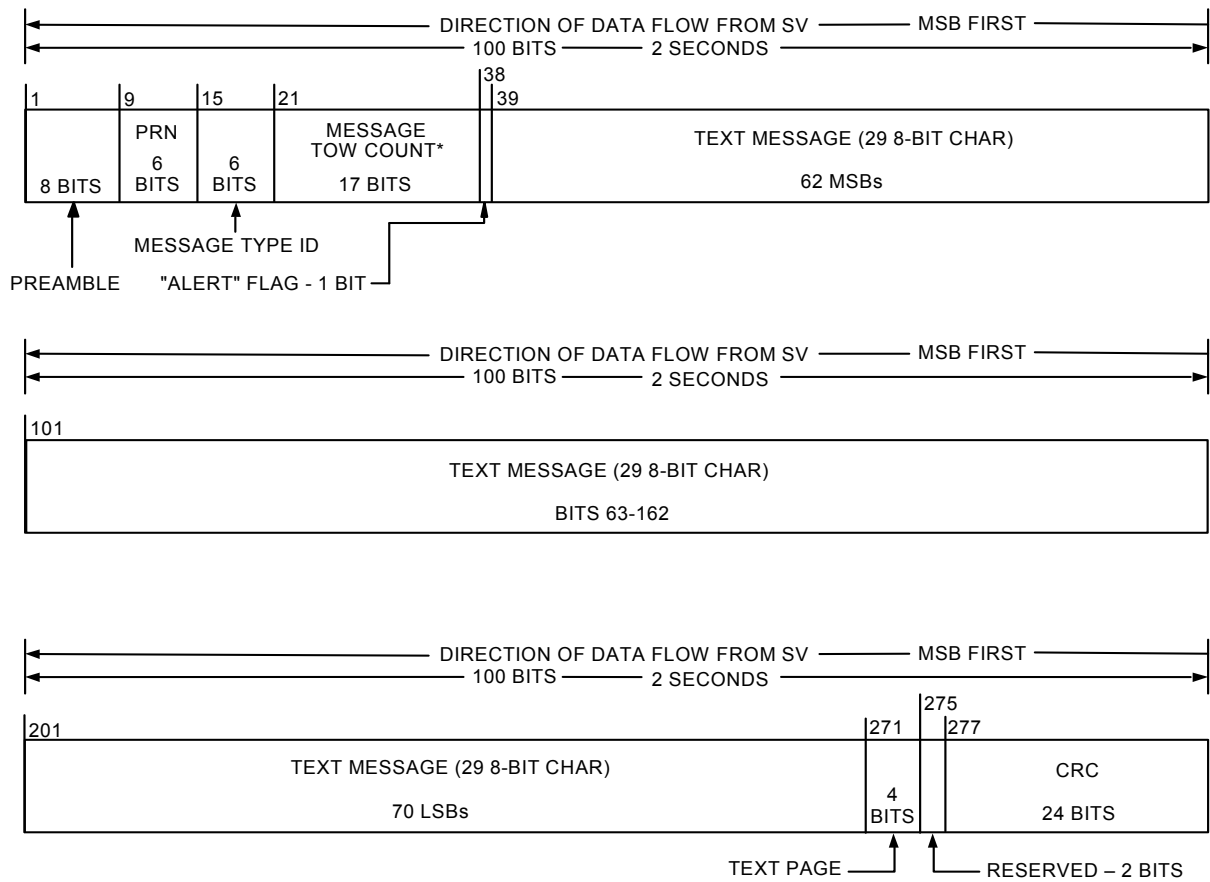

* MESSAGE TOW COUNT = 17 MSB OF ACTUAL TOW COUNT AT START OF NEXT 6-SECOND MESSAGE

Figure 20-14. Message type 15 - Text

20.3.3.1 Message Types 10 and 11 Ephemeris and Health Parameters.

20.3.3.1.1 Message Types 10 and 11 Ephemeris and Health Parameter Content. The contents of the SV health, ephemeris representation and accuracy parameters in message types 10 and 11 are defined below, followed by material pertinent to the use of the data. Message type 10, in conjunction with message type 11, provides users with the requisite data to calculate SV position. The general format of message types 10 and 11 consists of data fields for reference time tags, a set of gravitational harmonic correction terms, rates and rate corrections to quasi-Keplerian elements, and an accuracy indicator for ephemeris-related data.

The ephemeris parameters in the message type 10 and type 11 describe the orbit of the transmitting SV during the curve fit intervals of three hours. The nominal transmission interval is two hours, and shall coincide with the first two hours of the curve fit interval. The period of applicability for ephemeris data coincides with the entire three-hour curve fit interval. Table 20-I gives the definition of the orbital parameters using terminology typical of Keplerian orbital parameters; it is noted, however, that the transmitted parameter values are expressed such that they provide the best trajectory fit in Earth-Centered, Earth-Fixed (ECEF) coordinates for each specific fit interval. The user shall not interpret intermediate coordinate values as pertaining to any conventional coordinate system.

Any change in the message type 10 and 11 ephemeris data will be accomplished with a simultaneous change in the t_{oe} value (t_{oe} = Ephemeris data reference time of week). The CS (Block IIF) or SV (Block IIIA) will ensure that the t_{oe} value, for at least the first data set transmitted by an SV after an upload, is different from that transmitted prior to the cutover. See Section 20.3.4.5 of IS-GPS-200 for additional information regarding t_{oe} .

The CNAV message will contain information that allows users to operate when integrity is assured. This is accomplished using an integrity assured URA value in conjunction with an integrity status flag. The URA value is the RSS of URA_{oe} and URA_{oc}; URA is integrity assured to the enhanced level only when the integrity status flag is "1".

Bit 272 of Message Type 10 is the Integrity Status Flag (ISF). A "0" in bit position 272 indicates that the conveying signal is provided with the legacy level of integrity assurance. That is, the probability that the instantaneous URE of the conveying signal exceeds 4.42 times the upper bound value of the current broadcast URA index value, for more than 5.2 seconds, without an accompanying alert, is less than 1×10^{-5} per hour. A "1" in bit-position 272 indicates that the conveying signal is provided with an enhanced level of integrity assurance. That is, the probability that the instantaneous URE of the conveying signal exceeds 5.73 times the upper bound value of the current broadcast URA index value, for more than 5.2 seconds, without an accompanying alert, is less than 1×10^{-8} per hour. The probabilities associated with the nominal and lower bound values of the current broadcast URA index are not defined.

In this context, an "alert" is defined as any indication or characteristic in the conveying signal, as specified elsewhere in this document, which signifies that the conveying signal may be invalid and should not be used, such as, not Operational-Healthy, Non-Standard Code, parity error, etc. In this context, the term URA refers to the composite URA, calculated as the root-sum-squared of the individual URA components in the conveying signal.

20.3.3.1.1.1 Transmission Week Number. Bits 39 through 51 of message type 10 shall contain 13 bits which are a modulo-8192 binary representation of the current GPS week number at the start of the data set transmission interval (see paragraph 6.2.4 of IS-GPS-200). ~~These 13 bits are comprised of 10 LSBs (WN) that represent the 10 MSBs of the 29-bit Z count as qualified in paragraph 20.3.3.1.1 of IS-GPS-200, and 3 MSBs (WN_e) which are three extra bits to extend the range of transmission week number from 10 bits to 13 bits.~~

20.3.3.1.1.2 Signal Health (L1/L2/L5). The three, one-bit, health indication in bits 52 through 54 of message type 10 refers to the L1, L2, and L5 signals of the transmitting SV. The health of each signal is indicated by,

0 = Signal OK,

1 = Signal bad or unavailable.

The predicted health data will be updated at the time of upload when a new data set has been built by the CS. The transmitted health data may not correspond to the actual health of the transmitting SV.

Additional SV health data are given in the almanac in message types 12, 31, and 37. The data given in message type 10 may differ from that shown in the other messages of the transmitting SV and/or other SVs since the latter may be updated at a different time.

20.3.3.1.1.3 Data Predict Time of Week. Bits 55 through 65 of message type 10 shall contain the data predict time of week (t_{op}). The t_{op} term provides the epoch time of week of the state estimate utilized for the prediction of satellite quasi-Keplerian ephemeris parameters.

20.3.3.1.1.4 SV Accuracy. Bits 66 through 70 of message type 10 shall contain the ephemeris User Range Accuracy (URA_{oe}) index of the SV for the unauthorized (non-Precise Positioning Service) user. The URA_{oe} index shall provide the ephemeris-related user range accuracy index of the SV as a function of the current ephemeris message curve fit interval. While the ephemeris-related URA may vary over the ephemeris message curve fit interval, the URA_{oe} index (N) in message type 10 shall correspond to the maximum URA_{oe} expected over the entire curve fit interval.

The URA_{oe} index is a signed, two's complement integer in the range of +15 to -16 and has the following relationship to the ephemeris URA:

<u>URA_{oe} Index</u>	<u>URA_{oe} (meters)</u>
15	6144.00 < URA _{oe}
14	3072.00 < URA _{oe} ≤ 6144.00
13	1536.00 < URA _{oe} ≤ 3072.00
12	768.00 < URA _{oe} ≤ 1536.00
11	384.00 < URA _{oe} ≤ 768.00
10	192.00 < URA _{oe} ≤ 384.00
9	96.00 < URA _{oe} ≤ 192.00
8	48.00 < URA _{oe} ≤ 96.00
7	24.00 < URA _{oe} ≤ 48.00
6	13.65 < URA _{oe} ≤ 24.00
5	9.65 < URA _{oe} ≤ 13.65
4	6.85 < URA _{oe} ≤ 9.65
3	4.85 < URA _{oe} ≤ 6.85
2	3.40 < URA _{oe} ≤ 4.85
1	2.40 < URA _{oe} ≤ 3.40
0	1.70 < URA _{oe} ≤ 2.40
-1	1.20 < URA _{oe} ≤ 1.70
-2	0.85 < URA _{oe} ≤ 1.20
-3	0.60 < URA _{oe} ≤ 0.85
-4	0.43 < URA _{oe} ≤ 0.60
-5	0.30 < URA _{oe} ≤ 0.43
-6	0.21 < URA _{oe} ≤ 0.30
-7	0.15 < URA _{oe} ≤ 0.21
-8	0.11 < URA _{oe} ≤ 0.15
-9	0.08 < URA _{oe} ≤ 0.11
-10	0.06 < URA _{oe} ≤ 0.08
-11	0.04 < URA _{oe} ≤ 0.06
-12	0.03 < URA _{oe} ≤ 0.04
-13	0.02 < URA _{oe} ≤ 0.03
-14	0.01 < URA _{oe} ≤ 0.02
-15	URA _{oe} ≤ 0.01
-16	No accuracy prediction available—use at own risk

[Integrity properties of the URA are specified with respect to the upper bound values of the URA index \(see 20.3.3.1.1\)](#)

20.3.3.1.2 Message Types 10 and 11 Ephemeris Parameter Characteristics. For each ephemeris parameter contained in message types 10 and 11, the number of bits, the scale factor of the least significant bit (LSB) (which is the last bit received), the range, and the units are as specified in Table 20-I. See Figures 20-1 and 20-2 for complete bit allocation in message types 10 and 11.

20.3.3.1.3 User Algorithm for Determination of SV Position. The user shall compute the ECEF coordinates of position for the SV's antenna phase center (APC) utilizing a variation of the equations shown in Table 20-II. The ephemeris parameters are Keplerian in appearance; the values of these parameters, however, are produced by the CS [\(Block IIF\) or the SV \(Block IIIA\)](#) via a least squares curve fit of the predicted ephemeris of the SV APC (time-position quadruples; t, x, y, z expressed in ECEF coordinates). Particulars concerning the applicable coordinate system are given in Sections 20.3.3.4.3.3 and 20.3.3.4.3.4 of IS-GPS-200.

The sensitivity of the SV's position to small perturbations in most ephemeris parameters is extreme. The sensitivity of position to the parameters A , C_{rc-n} , and C_{rs-n} is about one meter/meter. The sensitivity of position to the angular parameters is on the order of 10^8 meters/semi-circle, and to the angular rate parameters is on the order of 10^{12} meters/semi-circle/second. Because of this extreme sensitivity to angular perturbations, the value of π used in the curve fit is given here. π is a mathematical constant, the ratio of a circle's circumference to its diameter. Here π is taken as 3.1415926535898.

Table 20-I. Message Types 10 and 11 Parameters (1 of 2)

Parameter		No. of Bits**	Scale Factor (LSB)	Effective Range***	Units
Parameter Symbol	Parameter Description	No. of Bits**	Scale Factor (LSB)	Effective Range***	Units
<u>WN Week No.</u>	<u>Week No.</u>	13	1		weeks
<u>URA_{oc} INDEX</u> <u>SV accuracy</u>	<u>SV accuracy</u>	5*			(see text)
Signal health (L1/L2/L5)		3	1		(see text)
t_{op}	Data predict time of week	11	300	604,500	seconds
ΔA ****	Semi-major axis difference at reference time	26*	2^{-9}		meters
\dot{A}	Change rate in semi-major axis	25*	2^{-21}		meters/sec
Δn_0	Mean Motion difference from computed value at reference time	17*	2^{-44}		semi-circles/sec
$\dot{\Delta n}_0$	Rate of mean motion difference from computed value	23*	2^{-57}		semi-circles/sec ²
M_{0-n}	Mean anomaly at reference time	33*	2^{-32}		semi-circles
e_n	Eccentricity	33	2^{-34}	0.03	dimensionless
ω_n	Argument of perigee	33*	2^{-32}		semi-circles

- * Parameters so indicated are two's complement, with the sign bit (+ or -) occupying the MSB;
- ** See Figure 20-1 for complete bit allocation in message type 10;
- *** Unless otherwise indicated in this column, effective range is the maximum range attainable with indicated bit allocation and scale factor.
- **** Relative to $A_{REF} = 26,559,710$ meters.

Table 20-I. Message Types 10 and 11 Parameters (2 of 2)

Table 20-I. Message Types 10 and 11 Parameters (2 of 2)					
Parameter		No. of Bits**	Scale Factor (LSB)	Effective Range***	Units
Parameter Symbol	Parameter Description	No. of Bits**	Scale Factor (LSB)	Effective Range***	Units
t_{oe}	Ephemeris data reference time of week	11	300	604,500	seconds
Ω_{0-n} ****	Reference right ascension angle	33*	2^{-32}		semi-circles
$\dot{\Delta \Omega}$ *****	Rate of right ascension difference	17*	2^{-44}		semi-circles/sec
i_{0-n}	Inclination angle at reference time	33*	2^{-32}		semi-circles
\dot{i}_{0-n}	Rate of inclination angle	15*	2^{-44}		semi-circles/sec
C_{is-n}	Amplitude of the sine harmonic correction term to the angle of inclination	16*	2^{-30}		radians
C_{ic-n}	Amplitude of the cosine harmonic correction term to the angle of inclination	16*	2^{-30}		radians
C_{rs-n}	Amplitude of the sine correction term to the orbit radius	24*	2^{-8}		meters
C_{rc-n}	Amplitude of the cosine correction term to the orbit radius	24*	2^{-8}		meters
C_{us-n}	Amplitude of the sine harmonic correction term to the argument of latitude	21*	2^{-30}		radians
C_{uc-n}	Amplitude of the sine harmonic correction term to the argument of latitude	21*	2^{-30}		radians
<p>* Parameters so indicated are two's complement, with the sign bit (+ or -) occupying the MSB;</p> <p>** See Figure 20-1 and Figure 20-2 for complete bit allocation in message types 10 and 11;</p> <p>*** Unless otherwise indicated in this column, effective range is the maximum range attainable with indicated bit allocation and scale factor.</p> <p>**** Ω_{0-n} is the right ascension angle at the weekly epoch (Ω_{0-w}) propagated to the reference time at the rate of right ascension $\{\dot{\Omega}_{REF}$ Table 20-II }.</p> <p>***** Relative to $\dot{\Omega}_{REF} = -2.6 \times 10^{-9}$ semi-circles/second.</p>					

Table 20-II. Elements of Coordinate System (part 1 of 2)

Element/Equation	Description
$\mu = 3.986005 \times 10^{14} \text{ meters}^3/\text{sec}^2$	WGS 84 value of the earth's gravitational constant for GPS user
$\dot{\Omega}_c = 7.2921151467 \times 10^{-5} \text{ rad/sec}$	WGS 84 value of the earth's rotation rate
$A_0 = A_{\text{REF}} + \Delta A *$	Semi-Major Axis at reference time
$A_k = A_0 + (\dot{A}) t_k$	Semi-Major Axis
$n_0 = \sqrt{\frac{\mu}{A_0^3}}$	Computed Mean Motion (rad/sec)
$t_k = t - t_{oc} **$	Time from ephemeris reference time
$\Delta n_A = \Delta n_0 + \frac{1}{2} \Delta \dot{n}_0 t_k$	Mean motion difference from computed value
$n_A = n_0 + \Delta n_A$	Corrected Mean Motion
$M_k = M_0 + n_A t_k$	Mean Anomaly
$M_k = E_k - e_n \sin E_k$	Kepler's equation for Eccentric Anomaly (radians) (may be solved by iteration)
$v_k = \tan^{-1} \left\{ \frac{\sin v_k}{\cos v_k} \right\}$ $= \tan^{-1} \left\{ \frac{\sqrt{1-e_n^2} \sin E_k / (1-e_n \cos E_k)}{(\cos E_k - e_n) / (1-e_n \cos E_k)} \right\}$	True Anomaly
$E_k = \cos^{-1} \left\{ \frac{e_n + \cos v_k}{1 + e_n \cos v_k} \right\}$	Eccentric Anomaly
<p>* $A_{\text{REF}} = 26,559,710$ meters</p> <p>** t is GPS system time at time of transmission, i.e., GPS time corrected for transit time (range/speed of light). Furthermore, t_k shall be the actual total difference between the time t and the epoch time t_{oc}, and must account for beginning or end of week crossovers. That is if t_k is greater than 302,400 seconds, subtract 604,800 seconds from t_k. If t_k is less than -302,400 seconds, add 604,800 seconds to t_k.</p>	

Table 20-II. Elements of Coordinate System (part 2 of 2)

Element/Equation *	Description
$\Phi_k = v_k + \omega_n$ $\delta u_k = C_{us-n} \sin 2\Phi_k + C_{uc-n} \cos 2\Phi_k$ $\delta r_k = C_{rs-n} \sin 2\Phi_k + C_{rc-n} \cos 2\Phi_k$ $\delta i_k = C_{is-n} \sin 2\Phi_k + C_{ic-n} \cos 2\Phi_k$ $u_k = \Phi_k + \delta u_k$ $r_k = A_k(1 - e_n \cos E_k) + \delta r_k$ $i_k = i_{o-n} + (i_{o-n}^\bullet) t_k + \delta i_k$ $\left. \begin{aligned} x_k' &= r_k \cos u_k \\ y_k' &= r_k \sin u_k \end{aligned} \right\}$ $\dot{\Omega} = \dot{\Omega}_{REF} + \Delta \dot{\Omega} \quad ***$ $\Omega_k = \Omega_{0-n} + (\dot{\Omega} - \dot{\Omega}_e) t_k - \dot{\Omega}_e t_{oe}$ $\left. \begin{aligned} x_k &= x_k' \cos \Omega_k - y_k' \sin \Omega_k \\ y_k &= x_k' \sin \Omega_k + y_k' \cos \Omega_k \\ z_k &= y_k' \sin i_k \end{aligned} \right\}$	<p>Argument of Latitude</p> <p>Argument of Latitude Correction</p> <p>Radial Correction</p> <p>Inclination Correction</p> <p style="text-align: right;">} Second Harmonic Perturbations</p> <p>Corrected Argument of Latitude</p> <p>Corrected Radius</p> <p>Corrected Inclination</p> <p>Positions in orbital plane</p> <p>Rate of Right Ascension</p> <p>Corrected Longitude of Ascending Node</p> <p>Earth-fixed coordinates of SV antenna phase center</p>
<p>*** $\dot{\Omega}_{REF} = -2.6 \times 10^{-9}$ semi-circles/second.</p>	

20.3.3.2 Message Types 30 through 37 SV Clock Correction Parameters.

20.3.3.2.1 Message Types 30 through 37 SV Clock Correction Parameter Content. The clock parameters in any one of message types 30 through 37 describe the SV time scale during the period of validity. ~~The clock parameters in a data set shall be valid during the interval of time in which they are transmitted and shall remain valid for an additional period of time after transmission of the next data set has started.~~ The parameters are applicable during the time in which they are transmitted. Beyond that time they are still applicable, however, the most recent data set should be used since the accuracy degrades over time.

The general format of message types 30 through 37 includes data fields for SV clock correction coefficients. Any one of message types 30 through 37 in conjunction with message types 10 and 11 provide users with the requisite data to correct SV time and to calculate SV position precisely. In general, any message ~~of~~ type 30 ~~to 39's (i.e. 30-39)~~ will provide SV clock correction parameters as described in this section.

20.3.3.2.1.1 SV Clock Correction. Any one of message types 30 through 37, Figure 20-3 through Figure 20-10, contains the parameters needed by the users for apparent SV clock correction. Bits 61 to 71 contain t_{oc} , clock data reference time of week. Bits 72 to 127 contain SV clock correction coefficients. The related algorithm is given in paragraph 20.3.3.2.3.

20.3.3.2.1.2 Data Predict Time of Week. Bits 39 through 49 of message types 30 through 37 shall contain the data predict time of week (t_{op}). The t_{op} term provides the epoch time of week of the state estimate utilized for the prediction of SV clock correction coefficients.

20.3.3.2.2 Clock Parameter Characteristics. The number of bits, the scale factors of the LSB (which is the last bit received), the range, and the units of clock correction parameters shall be as specified in Table 20-III.

20.3.3.2.3 User Algorithms for SV Clock Correction Data. The algorithms defined in paragraph 20.3.3.3.3.1 of IS-GPS-200 allow all users to correct the code phase time received from the SV with respect to both SV code phase offset and relativistic effects. However, since the SV clock corrections of equations in paragraph 20.3.3.3.3.1 of IS-GPS-200 are estimated by the CS using dual frequency L1 and L2 P(Y) code measurements, the single-frequency L5 user and the dual-frequency L1 and L5, and L2 and L5 users must apply additional terms to the SV clock corrections equations. These terms are described in paragraph 20.3.3.3.1.

Table 20-III. Clock Correction and Accuracy Parameters					
Parameter		No. of Bits**	Scale Factor (LSB)	Effective Range***	Units
Parameter Symbol	Parameter Description	No. of Bits**	Scale Factor (LSB)	Effective Range***	Units
t_{oc}	Clock Data Reference Time of Week	11	300	604,500	seconds
URA _{oc} Index	SV Clock Accuracy Index	5*			(see text)
URA _{oc1} Index	SV Clock Accuracy Change Index	3			(see text)
URA _{oc2} Index	SV Clock Accuracy Change Rate Index	3			(see text)
a _{f2-n}	SV Clock Drift Rate Correction Coefficient	10*	2 ⁻⁶⁰		sec/sec ²
a _{f1-n}	SV Clock Drift Correction Coefficient	20*	2 ⁻⁴⁸		sec/sec
a _{f0-n}	SV Clock Bias Correction Coefficient	26*	2 ⁻³⁵		seconds
<p>* Parameters so indicated are two's complement, with the sign bit (+ or -) occupying the MSB; ** See Figures 20-3 through 20-10 for complete bit allocation in message types 30 to 37; *** Unless otherwise indicated in this column, effective range is the maximum range attainable with indicated bit allocation and scale factor.</p>					

20.3.3.2.4 SV Clock Accuracy Estimates. Bits 50 through 54, and 55 through 57, and 58 through 60 of message types 30 through 37 shall contain the URA_{oc} Index, URA_{oc1} Index, and URA_{oc2} Index, respectively, of the SV (reference paragraph 6.2.1) for the unauthorized user. The URA_{oc} Index together with URA_{oc1} Index and URA_{oc2} Index shall give the clock-related user range accuracy of the SV as a function of time since the prediction (t_{op}) used to generate the uploaded clock correction polynomial terms.

Clock-related URA (URAoc) accounts for signal-in-space contributions to user range error that include, but are not limited to, the following: the net effect of clock parameter and code phase error in the transmitted signal for single-frequency users who correct the code phase as described in Section 20.3.3.3.1.1.1, as well as the net effect of clock parameter, code phase, and intersignal correction error for dual-frequency L1/L2 and L1/L5 users who correct for group delay and ionospheric effects as described in Section 20.3.3.3.1.2.2.

The user shall calculate the clock-related URA with the equation (in meters);

$$URA_{oc} = URA_{ocb} + URA_{oc1} (t - t_{op}) \quad \text{for } t - t_{op} \leq 93,600 \text{ seconds}$$

$$URA_{oc} = URA_{ocb} + URA_{oc1} (t - t_{op}) + URA_{oc2} (t - t_{op} - 93,600)^2 \quad \text{for } t - t_{op} > 93,600 \text{ seconds}$$

where

t = GPS time (must account for beginning or end of week crossovers),

t_{op} = time of week of the state estimate utilized for the prediction of satellite clock correction parameters.

The CS shall derive URA_{ocb} at time t_{op} which, when used together with URA_{oc1} and URA_{oc2} in the above equations, results in the minimum URA_{oc} that is greater than the predicted URA_{oc} during the entire duration up to 14 days after t_{op} .

The user shall use the broadcast URA_{oc} Index to derive URA_{ocb} . The index is a signed, two's complement integer in the range of +15 to -16 and has the following relationship to the clock-related user derived URA_{ocb} :

<u>URA_{oc} Index</u>	<u>URA_{ocb} (meters)</u>	
15	6144.00	$< URA_{ocb}$
14	3072.00	$< URA_{ocb} \leq 6144.00$
13	1536.00	$< URA_{ocb} \leq 3072.00$
12	768.00	$< URA_{ocb} \leq 1536.00$
11	384.00	$< URA_{ocb} \leq 768.00$
10	192.00	$< URA_{ocb} \leq 384.00$
9	96.00	$< URA_{ocb} \leq 192.00$
8	48.00	$< URA_{ocb} \leq 96.00$
7	24.00	$< URA_{ocb} \leq 48.00$
6	13.65	$< URA_{ocb} \leq 24.00$
5	9.65	$< URA_{ocb} \leq 13.65$
4	6.85	$< URA_{ocb} \leq 9.65$
3	4.85	$< URA_{ocb} \leq 6.85$
2	3.40	$< URA_{ocb} \leq 4.85$
1	2.40	$< URA_{ocb} \leq 3.40$
0	1.70	$< URA_{ocb} \leq 2.40$
-1	1.20	$< URA_{ocb} \leq 1.70$
-2	0.85	$< URA_{ocb} \leq 1.20$
-3	0.60	$< URA_{ocb} \leq 0.85$
-4	0.43	$< URA_{ocb} \leq 0.60$
-5	0.30	$< URA_{ocb} \leq 0.43$
-6	0.21	$< URA_{ocb} \leq 0.30$
-7	0.15	$< URA_{ocb} \leq 0.21$
-8	0.11	$< URA_{ocb} \leq 0.15$
-9	0.08	$< URA_{ocb} \leq 0.11$
-10	0.06	$< URA_{ocb} \leq 0.08$
-11	0.04	$< URA_{ocb} \leq 0.06$
-12	0.03	$< URA_{ocb} \leq 0.04$
-13	0.02	$< URA_{ocb} \leq 0.03$
-14	0.01	$< URA_{ocb} \leq 0.02$
-15		$URA_{ocb} \leq 0.01$
-16	No accuracy prediction available—use at own risk	

Integrity properties of the URA are specified with respect to the upper bound values of the URA index (see 20.3.3.1.1).

The user may use the upper bound value in the URA_{ocb} range corresponding to the broadcast index, thereby calculating the maximum URA_{oc} that is equal to or greater than the CS predicted URA_{oc} , or the user may use the lower bound value in the range which will provide the minimum URA_{oc} that is equal to or less than the CS predicted URA_{oc} .

The transmitted URA_{oc1} Index is an integer value in the range 0 to 7. URA_{oc1} Index has the following relationship to the URA_{oc1} :

$$URA_{oc1} = \frac{1}{2^N} \text{ (meters/second)}$$

where

$$N = 4 + URA_{oc1} \text{ Index}$$

The transmitted URA_{oc2} Index is an integer value in the range 0 to 7. URA_{oc2} Index has the following relationship to the URA_{oc2} .

$$URA_{oc2} = \frac{1}{2^N} \text{ (meters/second/second)}$$

where

$$N = 25 + URA_{oc2} \text{ Index}$$

20.3.3.3 Message Type 30 Ionospheric and Group Delay Correction Parameters.

20.3.3.3.1 Message Type 30 Ionospheric and Group Delay Correction Parameter Content. Message type 30 provides SV clock correction parameters (ref. Section 20.3.3.2) and ionospheric and group delay correction parameters. Bits 128 through 192 of message type 30 provide the group delay differential correction terms for L1, L2, and L5 signal users. Bits 193 through 256 provide the ionospheric correction parameters for single frequency user. The following algorithms shall apply when interpreting the correction parameters in the message.

20.3.3.3.1.1 Estimated L1-L2 Group Delay Differential. The group delay differential correction terms, T_{GD} , $ISC_{L1C/A}$, ISC_{L2C} are contained in bits 128 through 166 of message type 30. See paragraph 30.3.3.3.1.1 of IS-GPS-200. The bit lengths, scale factors, ranges, and units of these parameters are given in Table 20-IV. These group delay differential correction terms are also used for the benefit of single frequency L5-I5 and L5-Q5 users and dual frequency L1/L5 and L2/L5 users.

20.3.3.3.1.1.1 L1/L2 Inter-Signal Group Delay Differential Correction. See paragraph 30.3.3.3.1.1.1 of IS-GPS-200.

20.3.3.3.1.2 Estimated L5 Group Delay Differential. The group delay differential correction terms, T_{GD} , ISC_{L5I5} and ISC_{L5Q5} , for the benefit of single frequency L5-I5 and L5-Q5 users and dual frequency L1/L5 and L2/L5 users are contained in bits 128 through 140 and 167 through 192 of message type 30 (see Figure 20-3 for complete bit allocation). The bit lengths, scale factors, ranges, and units of these parameters are given in Table 20-IV. The bit string of “100000000000” shall indicate that the group delay value is not available. The related algorithms are given in paragraphs 20.3.3.3.1.2.1, 20.3.3.3.1.2.2, and 20.3.3.3.1.2.3.

Table 20- IV. Group Delay Differential Parameters ****				
Parameter	No. of Bits**	Scale Factor (LSB)	Effective Range***	Units
T _{GD}	13*	2 ⁻³⁵		seconds
ISC _{L1C/A}	13*	2 ⁻³⁵		seconds
ISC _{L2C}	13*	2 ⁻³⁵		seconds
ISC _{L5I5}	13*	2 ⁻³⁵		seconds
ISC _{L5Q5}	13*	2 ⁻³⁵		seconds

* Parameters so indicated are two's complement with the sign bit (+ or -) occupying the MSB;
 ** See Figure 20-3 for complete bit allocation in message type 30;
 *** Effective range is the maximum range attainable with indicated bit allocation and scale factor;
 **** The bit string of "100000000000" will indicate that the group delay value is not available.

20.3.3.3.1.2.1 L1/L5 Inter-Signal ~~Group Delay Differential~~ Correction. The L5 correction terms, T_{GD} , ISC_{L5I5} and ISC_{L5Q5} are provided by the CS to account for the effect of ~~SV group delay differential inter-signal biases~~ between L1 P(Y) and L2 P(Y), L1 P(Y) and L5 I5, and between L1 P(Y) and L5 Q5, respectively. These values are initially based on measurements made by the SV contractor during SV manufacture. The values of T_{GD} and ISC's for each SV may be subsequently updated to reflect the actual on-orbit group delay differential. For maximum accuracy, the single frequency L5 I5 user must use the correction terms to make further modifications to the code phase offset in paragraph 20.3.3.3.1 of IS-GPS-200 with the equation:

$$(\Delta t_{SV})_{L5I5} = \Delta t_{SV} - T_{GD} + ISC_{L5I5}$$

where; T_{GD} (see paragraph 20.3.3.3.2 of IS-GPS-200) and ISC_{L5I5} (described in paragraph 20.3.3.3.1.2) are provided to the user as message type 30 data. For maximum accuracy, the single frequency L5 Q5 user must use the correction terms to make further modifications to the code phase offset given by:

$$(\Delta t_{SV})_{L5Q5} = \Delta t_{SV} - T_{GD} + ISC_{L5Q5}$$

where; ISC_{L5Q5} (described in paragraph 20.3.3.3.1.2) is provided to the user as message type 30 data.

The values of ISC_{L5I5} and ISC_{L5Q5} are measured values that represent the mean SV group delay differential between the L1 P(Y)-code and the L5 I5-code or L5 Q5-code respectively as follows.

$$ISC_{L5I5} = t_{L1P(Y)} - t_{L5I5}$$

$$ISC_{L5Q5} = t_{L1P(Y)} - t_{L5Q5}$$

where t_{Lix} is the GPS time the i^{th} frequency x signal (a specific epoch of the signal) is transmitted from the SV antenna phase center.

20.3.3.3.1.2.2 L1/L5 Ionospheric Correction. The two frequency (L1-C/A and L5 I5) user shall correct for the group delay and ionospheric effects by applying the relationship:

$$PR = \frac{(PR_{L5I5} - \gamma_{15} PR_{L1C/A}) + c(ISC_{L5I5} - \gamma_{15} ISC_{L1C/A})}{1 - \gamma_{15}} - cT_{GD}$$

The two frequency (L1 C/A and L5 Q5) user shall correct for the group delay and ionospheric effects by applying the relationship:

$$PR = \frac{(PR_{L5Q5} - \gamma_{15} PR_{LIC/A}) + c(ISC_{L5Q5} - \gamma_{15} ISC_{LIC/A})}{1 - \gamma_{15}} - cT_{GD}$$

where

- PR = pseudorange corrected for ionospheric effects,
- PR_i = pseudorange measured on the channel indicated by the subscript;
- ISC_i = inter-signal correction for the channel indicated by the subscript (see paragraph 20.3.3.3.1.2),
- T_{GD} = see paragraph 20.3.3.3.2 of IS-GPS-200,
- c = speed of light (see paragraph 20.3.4.3),

and where, denoting the nominal center frequencies of L1 and L5 as f_{L1} and f_{L5} respectively,

$$\gamma_{15} = (f_{L1}/f_{L5})^2 = (1575.42/1176.45)^2 = (154/115)^2.$$

20.3.3.3.1.2.3 L2/L5 Ionospheric Correction. The two frequency (L2 C and L5 I5) user shall correct for the group delay and ionospheric effects by applying the relationship:

$$PR = \frac{(PR_{L5I5} - \gamma_{25}PR_{L2C}) + c(ISC_{L5I5} - \gamma_{25}ISC_{L2C})}{1 - \gamma_{25}} - cT_{GD}$$

The two frequency (L2 C and L5 Q5) user shall correct for the group delay and ionospheric effects by applying the relationship:

$$PR = \frac{(PR_{L5Q5} - \gamma_{25}PR_{L2C}) + c(ISC_{L5Q5} - \gamma_{25}ISC_{L2C})}{1 - \gamma_{25}} - cT_{GD}$$

where

- PR = pseudorange corrected for ionospheric effects,
- PR_i = pseudorange measured on the channel indicated by the subscript,
- ISC_i = inter-signal correction for the channel indicated by the subscript (see paragraph 20.3.3.3.1.2),
- T_{GD} = see paragraph 20.3.3.3.2 of IS-GPS-200,
- c = speed of light (see paragraph 20.3.4.3).

and where, denoting the nominal center frequencies of L2 and L5 as f_{L2} and f_{L5} respectively.

$$\gamma_{25} = (f_{L2}/f_{L5})^2 = (1227.6/1176.45)^2 = (24/23)^2$$

20.3.3.3.1.3 Ionospheric Data. The ionospheric parameters which allow the “L5 only” user to utilize the ionospheric model for computation of the ionospheric delay are contained in message type 30. The “one frequency” user should use the model given in Figure 20-4 of IS-GPS-200 to make this correction. The calculated value of T_{iono} (T_{iono} = ionospheric correction parameter) in the model is referred to the L1 frequency; if the user is operating on the L5 frequency, the correction term must be multiplied by γ₁₅ (reference paragraph 20.3.3.3.1.2.2). It is estimated that the use of this model will provide at least a 50 percent reduction in the single-frequency user’s RMS error due to ionospheric propagation effects. The bit lengths, scale factors, ranges, and units of these parameters are given in Table 20-X of IS-GPS-200 (See Figure 20-3 for complete ionospheric bit allocation).

The ionospheric data shall be updated by the CS at least once every six days while the CS is able to upload the SVs. If the CS is unable to upload the SVs, the ionospheric data transmitted by the SVs may not be accurate. During extended operations or in the Autonav mode, if the CS is unable to upload the SVs, the use of this model will yield unpredictable results.

20.3.3.3.1.4 Example Application of Correction Parameters. A typical system application of the correction parameters for a user receiver is shown in Figure 20-15. The ionospheric model referred to in Figure 20-15 is discussed in paragraph 20.3.3.3.1.3.

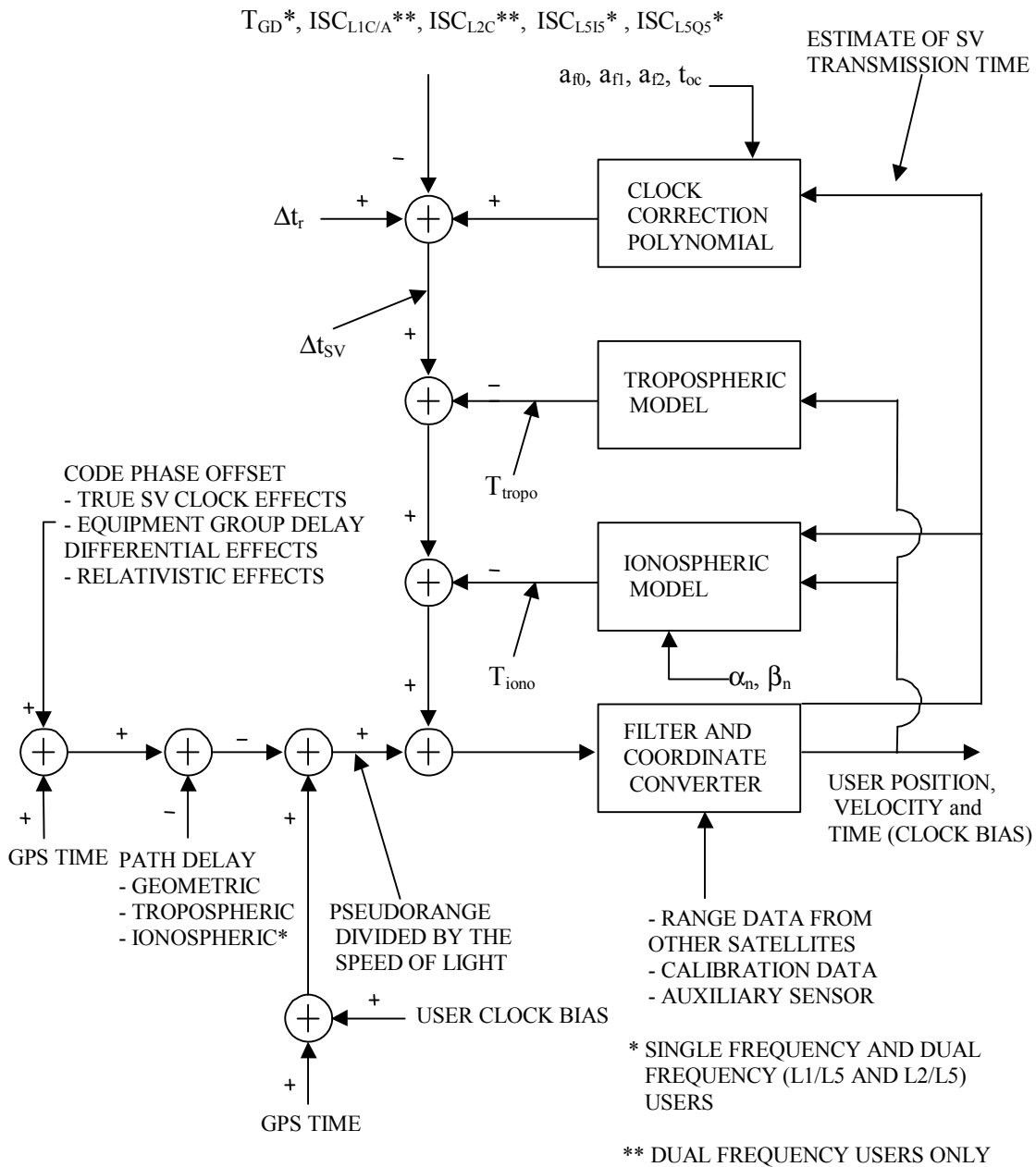

Figure 20-15 Sample Application of Correction Parameters

20.3.3.4 Message Types 31, 12 and 37 Almanac Parameters. The almanac parameters are provided in any one of message types 31, 37, and 12. Message type 37 provides Midi almanac parameters and the reduced almanac parameters are provided in either message type 31 or type 12. The SV shall broadcast both message types 31 (and/or 12) and 37. However, the reduced almanac parameters (i.e. message types 31 and/or 12) for the complete set of SVs in the constellation will be broadcast by a SV using shorter duration of time compared to the broadcast of the complete set of Midi almanac parameters (i.e. message type 37). The parameters are defined below, followed by material pertinent to the use of the data.

20.3.3.4.1 Almanac Reference Week. Bits 39 through 51 of message types 12, and bits 128 through 140 of message type 31 and 37 shall indicate the number of the week (WN_{a-n}) to which the almanac reference time (t_{oa}) is referenced (see paragraph 20.3.3.4.2). The WN_{a-n} term consists of 13 bits which shall be a modulo-8192 binary representation of the GPS week number (see paragraph 6.2.4) to which the t_{oa} is referenced. Bits 52 through 59 of message types 12, and bits 141 to 148 of message types 31 and 37 shall contain the value of t_{oa} , which is referenced to this WN_{a-n} .

20.3.3.4.2 Almanac Reference Time. See paragraph 20.3.3.5.2.2 of IS-GPS-200.

20.3.3.4.3 SV PRN Number. Bits 149 through 154 of message type 37 and bits 1 through 6 in each packet of reduced almanac shall specify PRN number of the SV whose almanac or reduced almanac, respectively, is provided in the message or in the packet.

20.3.3.4.4 Signal Health (L1/L2/L5). The three, one-bit, health indication in bits 155, 156 and 157 of message type 37 and bits 29,30 and 31 of each packet of reduced almanac refers to the L1, L2, and L5 signals of the SV whose PRN number is specified in the message or in the packet. For each health indicator, a “0” signifies that all navigation data are okay and “1” signifies that some or all navigation data are bad. The predicted health data will be updated at the time of upload when a new reduced almanac has been built by the CS. The transmitted health data may not correspond to the actual health of the transmitting SV or other SVs in the constellation.

20.3.3.4.5 Midi Almanac Parameter Content. Message type 37, Figure 20-10, provides Midi almanac data for a SV whose PRN number is specified in the message. The number of bits, the scale factor (LSB), the range, and the units of the almanac parameters are given in Table 20-V. The user algorithm is essentially the same as the user algorithm used for computing the precise ephemeris as specified in Table 20-IV of IS-GPS-200. Other parameters appearing in the equations of Table 20-IV of IS-GPS-200, but not provided by the Midi almanac with the reference values, are set to zero for SV position determination. See paragraph 20.3.3.5.2.3 of IS-GPS-200 for almanac time parameters.

Table 20-V. Midi Almanac Parameters

Parameter	No. of Bits**	Scale Factor (LSB)	Effective Range***	Units
t_{oa}	8	2^{12}	602,112	seconds
e	11	2^{-16}		dimensionless
δ_i ****	11*	2^{-14}		semi-circles
$\dot{\Omega}$	11*	2^{-33}		semi-circles/sec
\sqrt{A}	17	2^{-4}		$\sqrt{\text{meters}}$
Ω_0	16*	2^{-15}		semi-circles
ω	16*	2^{-15}		semi-circles
M_0	16*	2^{-15}		semi-circles
a_{f0}	11*	2^{-20}		seconds
a_{f1}	10*	2^{-37}		sec/sec

* Parameters so indicated shall be two's complement with the sign bit (+ or -) occupying the MSB;

** See Figure 20-10 for complete bit allocation in message type 37;

*** Unless otherwise indicated in this column, effective range is the maximum range attainable with indicated bit allocation and scale factor;

**** Relative to $i_0 = 0.30$ semi-circles.

20.3.3.4.6 Reduced Almanac Parameter Content. Message type 31, Figure 20-4, provides SV clock correction parameters (ref. Section 20.3.3.2) and reduced almanac data packets for 4 SVs. Message type 12, Figure 20-11 contains reduced almanac data packets for 7 SVs.

20.3.3.4.6.1 Reduced Almanac Data. Message types 31 or 12 contains reduced almanac data and SV health words for SVs in the constellation. The reduced almanac data of a SV is broadcast in a packet of 31 bits long, as described in Figure 20-16. The reduced almanac data are a subset of the almanac data which provide less precise ephemeris. The reduced almanac data values are provided relative to pre-specified reference values. The number of bits, the scale factor (LSB), the ranges, and the units of the reduced almanac parameters are given in Table 20-VI. The algorithms and other material related to the use of the reduced almanac data are given in Section 20.3.3.4.6.2.

The reduced almanac parameters shall be updated by the CS at least once every 3 days while the CS is able to upload the SVs. If the CS is unable to upload the SVs, the accuracy of the reduced almanac parameters transmitted by the SVs will degrade over time.

20.3.3.4.6.2 Reduced Almanac Packet. The following shall apply when interpreting the data provided in each packet of reduced almanac (see Figure 20-16).

20.3.3.4.6.2.1 Reduced Almanac. The reduced almanac data is provided in bits 7 through 28 of each packet. The data from a packet along with the reference values (see Table 20-VI) provide ephemeris with further reduced precision. The user algorithm is essentially the same as the user algorithm used for computing the precise ephemeris from the parameters of the message types 10 and 11 (see paragraph 20.3.3.1.3 and Table 20-II). Other parameters appearing in the equations of Table 20-II, but not provided by the reduced almanac with the reference values, are set to zero for SV position determination.

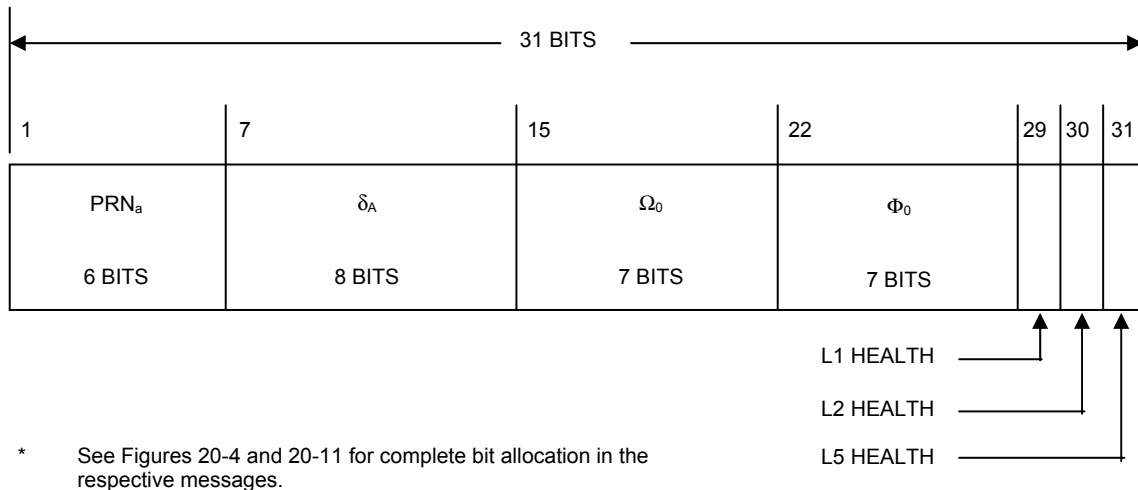

Figure 20-16. Reduced Almanac Packet Content

Table 20-VI Reduced Almanac Parameters				
Parameter*****	No. of Bits	Scale Factor (LSB)	Effective Range **	Units
δ_A ***	8 *	2^{+9}	**	meters
Ω_0	7 *	2^{-6}	**	semi-circles
Φ_0 *****	7 *	2^{-6}	**	semi-circles

* Parameters so indicated shall be two's complement with the sign bit (+ or -) occupying the MSB;
 ** Effective range is the maximum range attainable with indicated bit allocation and scale factor;
 *** Relative to $A_{ref} = 26,559,710$ meters;
 **** $\Phi_0 =$ Argument of Latitude at Reference Time = $M_0 + \omega$;
 ***** Relative to following reference values:
 $e = 0$
 $\delta_i = +0.0056$ semi-circles ($i = 55$ degrees)
 $\dot{\Omega} = -2.6 \times 10^{-9}$ semi-circles/second

20.3.3.5 Message Type 32 Earth Orientation Parameters (EOP). The earth orientation parameters are provided in message type 32. The parameters are defined below, followed by material pertinent to the use of the data.

20.3.3.5.1 EOP Content. Message type 32, Figure 20-5, provides SV clock correction parameters (ref. Section 20.3.3.2) and earth orientation parameters. The EOP message provides users with parameters to construct the ECEF

and ECI coordinate transformation (a simple transformation method is defined in Section 20.3.3.4.3.3.2 of IS-GPS-200). The number of bits, scale factors (LSBs), the ranges, and the units of all EOP fields of message type 32 are given in Table 20-VII.

20.3.3.5.1.1 User Algorithm for Application of the EOP. The EOP fields in the message type 32 contain the EOP needed to construct the ECEF-to-ECI coordinate transformation. The user computes the ECEF position of the SV antenna phase center using the equations shown in Table 20-II. The coordinate transformation, for translating to the corresponding ECI SV antenna phase center position, is derived using the equations shown in Table 20-VIII. The coordinate systems are defined in Section 20.3.3.4.3.3 of IS-GPS-200. The equations described in this section are based on (International Earth Rotation and Reference Systems Service) IERS Technical Note 21. However, these equations will be updated to a new Technical Note in the next revision TBD.

An ECI position, R_{eci} , is related to an ECEF position, R_{ecef} , by a series of rotation matrices as following:

$$R_{ecef} = [A][B][C][D]R_{eci} ,$$

where the rotation matrices, A, B, C, and D, represent the effects of Polar Motion, Earth Rotation, Nutation and Precession, respectively. The message type 32 specifies the EOP parameters used in the construction of the Polar Motion, A, and Earth Rotation, B, matrices.

The rotation matrices, A, B, C and D are specified in terms of elementary rotation matrices $R_i(\alpha)$, where α is a positive rotation about the i^{th} – axis ordinate, as follows:

$$R_1(\alpha) = \begin{bmatrix} 1 & 0 & 0 \\ 0 & \cos(\alpha) & \sin(\alpha) \\ 0 & -\sin(\alpha) & \cos(\alpha) \end{bmatrix} , \quad R_2(\alpha) = \begin{bmatrix} \cos(\alpha) & 0 & -\sin(\alpha) \\ 0 & 1 & 0 \\ \sin(\alpha) & 0 & \cos(\alpha) \end{bmatrix}$$

$$R_3(\alpha) = \begin{bmatrix} \cos(\alpha) & \sin(\alpha) & 0 \\ -\sin(\alpha) & \cos(\alpha) & 0 \\ 0 & 0 & 1 \end{bmatrix}$$

The user shall compute the Inertial-to-Geodetic rotation matrix, ABCD using the equations shown in Table 20-VIII.

Table 20-VII. Earth Orientation Parameters

Table 20-VII. Earth Orientation Parameters					
Parameter		No. of Bits**	Scale Factor (LSB)	Effective Range***	Units
Parameter Symbol	Parameter Description	No. of Bits**	Scale Factor (LSB)	Effective Range***	Units
t_{EOP}	EOP Data Reference Time	16	2^4	604,784	seconds
PM_X^\dagger	X-Axis Polar Motion Value at Reference Time.	21*	2^{-20}	1	arc-seconds
$PM_X^\dot{}$	X-Axis Polar Motion Drift at Reference Time.	15*	2^{-21}	7.8125×10^{-3}	arc-seconds/day
PM_Y^{\ddagger}	Y-Axis Polar Motion Value at Reference Time.	21*	2^{-20}	1	arc-seconds
$PM_Y^\dot{}$	Y-Axis Polar Motion Drift at Reference Time.	15*	2^{-21}	7.8125×10^{-3}	arc-seconds/day
$\Delta UT1^{\dagger\dagger}$	UT1-UTC Difference at Reference Time.	31*	2^{-24}	64	seconds
$\Delta UT1^{\dot{\dagger}\dagger}$	Rate of UT1-UTC Difference at Reference Time	19*	2^{-25}	7.8125×10^{-3}	seconds/day

* Parameters so indicated are two's complement, with the sign bit (+ or -) occupying the MSB;

** See Figure 20-5 for complete bit allocation in message type 32;

*** Unless otherwise indicated in this column, effective range is the maximum range attainable with indicated bit allocation and scale factor.

† Represents the predicted angular displacement of instantaneous Celestial Ephemeris Pole with respect to semi-minor axis of the reference ellipsoid along Greenwich meridian.

‡‡ Represents the predicted angular displacement of instantaneous Celestial Ephemeris Pole with respect to semi-minor axis of the reference ellipsoid on a line directed 90° west of Greenwich meridian.

††† With zonal tides restored.

Table 20-VIII. Application of EOP Parameters (Part 1 of 2)

Element/Equation	Description
$\text{TDT} = t + 51^{\text{S}}.184$	Compute Terrestrial Dynamical Time relative to GPS Time t
$\text{J.E.D.} = \text{TDT expressed in days of 86400 sec}$	Compute Julian Ephemeris Date
$g = \frac{\pi}{180^\circ} \left[357.528 + 35999.05 \frac{\text{J.E.D.} - 2451545}{36525} \right]$	Compute Mean Anomaly of Earth in its orbit, g
$\text{J.B.D.} = \text{J.E.D.} + \frac{0^{\text{S}}001658 \sin(g + 0.0167 \sin g)}{86400\text{s}}$	Compute Julian Date in Barycentric Dynamical Time
$T = \frac{\text{J.B.D.} - 2451545}{36525}$	Compute time from J2000 Julian Epoch in Julian Centuries
$\begin{aligned} \zeta &= 2306''.2181 T + 0''.30188 T^2 + 0''.017998 T^3 \\ z &= 2306''.2181 T + 1''.09468 T^2 + 0''.018203 T^3 \\ \theta &= 2004''.3109 T - 0''.42665 T^2 - 0''.041833 T^3 \end{aligned}$	Compute Precession Fundamental Angles at time t
$D = R_3(-90^\circ - z) R_1(\theta) R_3(90^\circ - \zeta)$	Calculate Precession Matrix at time, t
$\begin{aligned} \bar{\epsilon} &= 23^\circ 26' 21''.448 - 46''.815 T - 0''.00059 T^2 \\ &+ 0''.001813 T^3 \end{aligned}$	Compute Mean Obliquity, $\bar{\epsilon}$, at time t
$C = R_1(-(\bar{\epsilon} + \Delta\epsilon)) R_3(-\Delta\psi) R_1(\bar{\epsilon})$	Compute Nutation Matrix at time, t

Table 20-VIII. Application of EOP Parameters (Part 2 of 2)

Element/Equation	Description
$\Delta\psi = \sum_{i=1}^{106} a_i \sin\left(\sum_{j=1}^5 e_j E_j\right) \text{ }^{\dagger\dagger}$	Nutation in Longitude
$\Delta\varepsilon = \sum_{i=1}^{64} b_i \cos\left(\sum_{j=1}^5 e_j E_j\right) \text{ }^{\dagger\dagger}$	Nutation in Obliquity
$UT1 = UTC + \Delta UT1 + \dot{\Delta UT1}(t - t_{EOP})$	Compute Universal Time at time t
$T_U = \frac{J.D. - 2451545}{36525}$ <p>where J.D. = UT1 expressed in days of 86400 sec</p>	Compute Universal Time from J2000 Julian Epoch in Julian Centuries
$\bar{\alpha} = \frac{2\pi}{24^h} \left(\begin{array}{l} UT1 + 6^h 41^m 50^s 54841 \\ + 8640184^s 812866 T_U \\ + 0^s 093104 T_U^2 - 6^s 2 \times 10^{-6} T_U^3 \end{array} \right)$	Compute Mean Greenwich Hour Angle
$\alpha = \bar{\alpha} + \Delta\psi \cos(\bar{\varepsilon} + \Delta\varepsilon)$	Compute True Greenwich Hour Angle
$B = R_3(\alpha)$	Compute Rotation Matrix at time, t
$A = R_2(-x_p) R_1(-y_p)$	Compute Polar Motion Matrix at time, t
<p>where $x_p = PM_X + PM_X \dot{X}(t - t_{EOP})$ $y_p = PM_Y + PM_Y \dot{Y}(t - t_{EOP})$</p>	
$ABCD = [A][B][C][D]$	Compute Inertial-to-Geodetic Rotation matrix, ABCD
<p>t is GPS system time at time of transmission, i.e., GPS time corrected for transit time (range/speed of light).</p>	
<p>^{††} The Nutation in Longitude and the Nutation in Obliquity are as described in The Astronomical Almanac (1983), pp. S23-S26, evaluated at time T.</p>	

20.3.3.6 Message Type 33 Coordinated Universal Time (UTC) Parameters. Message type 33, Figure 20-6, contains the UTC parameters. The contents of message type 33 are defined below, followed by material pertinent to the use of the UTC data.

20.3.3.6.1 UTC Parameter Content. Message type 33 provides SV clock correction parameters (ref. Section 20.3.3.2) and also, shall contain the parameters related to correlating UTC (USNO) time with GPS Time. The bit lengths, scale factors, ranges, and units of these parameters are given in Table 20-IX. See Figure 20-6 for complete bit allocation in message type 33.

The parameters relating GPS time to UTC (USNO) shall be updated by the CS at least once every three days while the CS is able to upload the SVs. If the CS is unable to upload the SVs, the accuracy of the UTC parameters transmitted by the SVs will degrade over time.

20.3.3.6.2 UTC and GPS Time. Message type 33 includes: (1) the parameters needed to relate GPS Time to UTC (USNO), and (2) notice to the user regarding the scheduled future or recent past (relative to NAV message upload) value of the delta time due to leap seconds (Δt_{LSF}), together with the week number (WN_{LSF}) and the day number (DN) at the end of which the leap second becomes effective. Information required ~~using to use~~ **using to use (and calculate)** these parameters ~~to calculate~~ t_{UTC} is in paragraph 20.3.3.5.2.4 of IS-GPS-200 except the following definition of Δt_{UTC} shall be used.

$$\Delta t_{UTC} = \Delta t_{LS} + A_{0-n} + A_{1-n} (t_E - t_{ot} + 604800 (WN - WN_{ot})) + A_{2-n} (t_E - t_{ot} + 604800 (WN - WN_{ot}))^2 \text{ seconds}$$

Table 20-IX. UTC Parameters					
Parameter		No. of Bits**	Scale Factor (LSB)	Effective Range***	Units
<u>Parameter Symbol</u>	<u>Parameter Description</u>	<u>No. of Bits**</u>	<u>Scale Factor (LSB)</u>	<u>Effective Range***</u>	<u>Units</u>
A _{0-n}	Bias coefficient of GPS time scale relative to UTC time scale	16*	2 ⁻³⁵		Seconds
A _{1-n}	Drift coefficient of GPS time scale relative to UTC time scale	13*	2 ⁻⁵¹		sec/sec
A _{2-n}	Drift rate correction coefficient of GPS time scale relative of UTC time scale	7*	2 ⁻⁶⁸		sec/sec ²
Δt _{LS}	Current or past leap second count	8*	1		seconds
t _{ot}	Time data reference Time of Week	16	2 ⁴	604,784	seconds
WN _{ot}	Time data reference Week Number	13	1		weeks
WN _{LSF}	Leap second reference Week Number	8	1		weeks
DN	Leap second reference Day Number	4****	1		days
Δt _{LSF}	Current or future leap second count	8*	1		seconds
<p>* Parameters so indicated shall be two's complement with the sign bit (+ or -) occupying the MSB; ** See Figure 20-6 for complete bit allocation *** Unless otherwise indicated in this column, effective range is the maximum range attainable with indicated bit allocation and scale factor; **** Right justified.</p>					

20.3.3.7 Message Types 34, 13, and 14 Differential Correction Parameters. Differential Correction (DC)

parameters are provided either in message types 34, or in types 13 and 14. These parameters provide users with sets of correction terms that apply to the clock and ephemeris data transmitted by other SVs. DC parameters are grouped in packets, as described in the next sections. The availability of these message types is subject to the control and determination of the CS.

20.3.3.7.1 Differential Correction Parameters Content. Message type 34 provides SV clock correction parameters (ref. Section 20.3.3.2) and also, shall contain DC parameters that apply to the clock and ephemeris data transmitted by another SV. One message type 34, Figure 20-7, shall contain 34 bits of clock differential correction (CDC) parameters and 92 bits of ephemeris differential correction (EDC) parameters for one SV other than the transmitting SV. Bit 150 of message type 34 shall be a DC Data Type indicator that indicates the data type for which the DC parameters apply. Zero (0) signifies that the corrections apply to L5 CNAV data, $D_5(t)$, and one (1) signifies that the corrections apply to NAV data, $D(t)$, described in Appendix II of IS-GPS-200.

Message types 13 and 14 together also provide DC parameters. Message type 13, Figure 20-12, shall contain CDC parameters applicable to 6 SVs and message type 14, Figure 20-13, shall contain EDC parameters applicable to 2 SVs. There shall be a DC Data Type indicator preceding each CDC or EDC packet. The content of an individual data packet is depicted in Figure 20-17. The number of bits, scale factors (LSB), the ranges, and the units of all fields in the DC packet are given in Table 20-X.

20.3.3.7.2 DC Data Packet. Each DC data packet contains: corrections to SV clock polynomial coefficients provided in any one of the message types 30 to 37 of the corresponding SV; corrections to quasi-Keplerian elements referenced to t_{OD} of the corresponding SV; User Differential Range Accuracy (UDRA) and UDRA indices that enables users to estimate the accuracy obtained after corrections are applied. Each DC packet is made up of two different segments. The first segment contains 34 bits for the CDC parameters and the second segment contains 92 bits of EDC parameters totaling 126 bits. The CDC and EDC parameters form an indivisible pair and users must utilize CDC and EDC as a pair. Users must utilize CDC and EDC data pairs of the same t_{op-D} (t_{op-D} =DC data predict time of week) and of the same t_{OD} .

20.3.3.7.2.1 Differential Correction Data Predict Time of Week. The DC data predict time of week (t_{op-D}) provides the epoch time of week, in increments of 300 seconds (i.e. five minutes), at which the prediction for the associated DC data was performed.

20.3.3.7.2.2 Time of Differential Correction Data. The time of DC data, t_{OD} , specifies the reference time of week, in increments of 300 seconds (i.e., five minutes) relative to the GPS week, for the associated CDC and EDC data.

20.3.3.7.2.3 SV PRN Identification. The PRN ID of both CDC and EDC of Figure 20-17 identifies the satellite to which the subject 126-bit differential correction packet data applies (by PRN code assignment). A value of all ones “11111111” in any PRN ID field shall indicate that no DC data is contained in the remainder of the data block. In this event, the remainder of the data block shall be filler bits, i.e., alternating ones and zeros beginning with one.

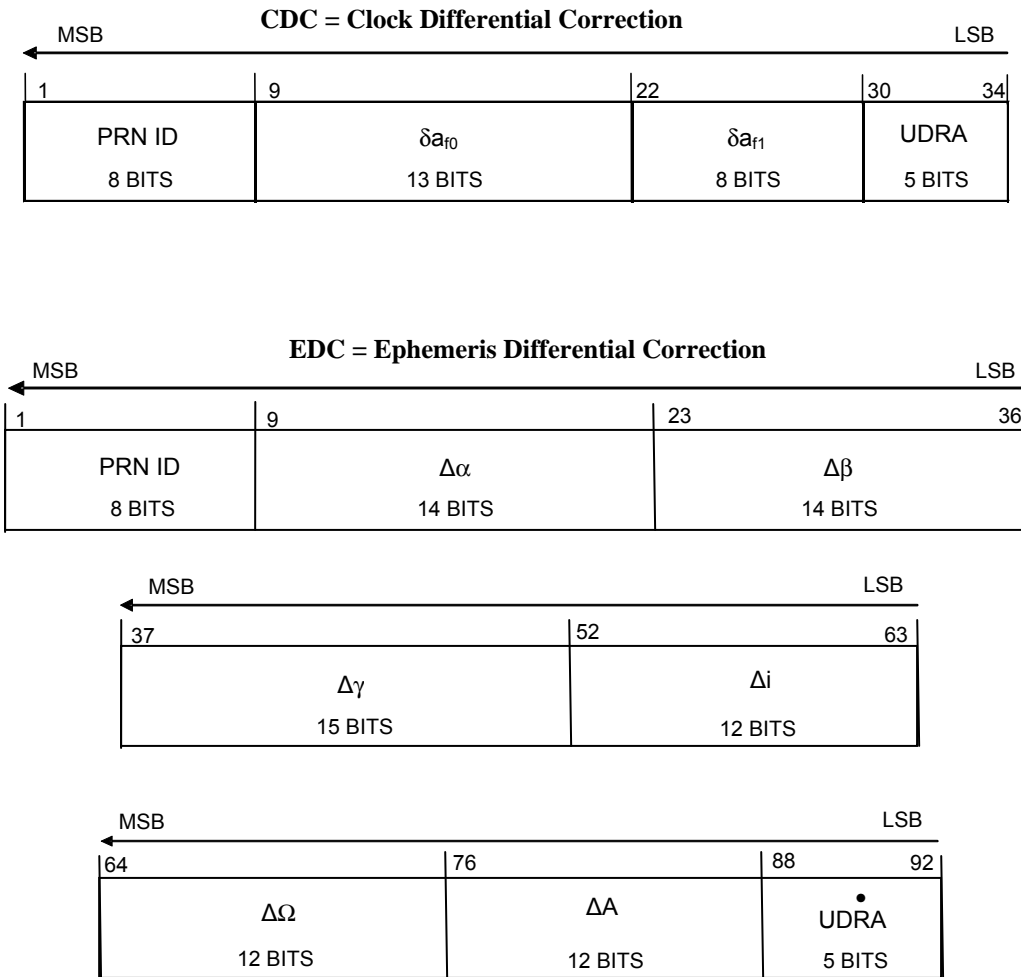

Figure 20-17. Differential Correction Data Packet

Table 20-X. Differential Correction Parameters

<u>Parameter</u>	<u>No. of Bits**</u>	<u>Scale Factor (LSB)</u>	<u>Effective Range***</u>	<u>Units</u>	
<u>Parameter Symbol</u>	<u>Parameter Description</u>	<u>No. of Bits**</u>	<u>Scale Factor (LSB)</u>	<u>Effective Range***</u>	<u>Units</u>
PRN ID		8			see text
δa_{f0}	SV Clock Bias Correction	13*	2^{-35}		seconds
δa_{f1}	SV Clock Drift Correction	8*	2^{-51}		seconds/second
UDRA	User Differential Range Accuracy Index.	5*			see text
$\Delta\alpha$	Alpha Correction to Ephemeris Parameters	14*	2^{-34}		dimensionless
$\Delta\beta$	Beta Correction to Ephemeris Parameters	14*	2^{-34}		dimensionless
$\Delta\gamma$	Gamma Correction to Ephemeris Parameters	15*	2^{-32}		semi-circles
Δi	Angle of Inclination Correction	12*	2^{-32}		semi-circles
$\Delta\Omega$	Angle of Right Ascension Correction	12*	2^{-32}		semi-circles
ΔA	Semi-Major Correction	12*	2^{-9}		meters
$\dot{\text{UDRA}}$	Change Rate of User Differential Range Accuracy Index	5*			see text

* Parameters so indicated are two's complement, with the sign bit (+ or -) occupying the MSB;
 ** See Figures 20-7, 11 and 12 for complete bit allocation in message types 34, 13 and 14.
 *** Unless otherwise indicated in this column, effective range is the maximum range attainable with indicated bit allocation and scale factor.

20.3.3.7.3 Application of Clock-Related Differential Correction Data. The SV PRN code phase offset, uncorrected by clock correction coefficient updates, is given by equation 2 in 20.3.3.3.3.1 of IS-GPS-200 (see paragraph 20.3.3.2.3). If the matched pair of DC data for the subject SV is available, the user may apply clock correction coefficient update values by;

$$\Delta t_{sv} = (a_{f0} + \delta a_{f0}) + (a_{f1} + \delta a_{f1})(t - t_{oc}) + a_{f2}(t - t_{oc})^2 + \Delta t_r$$

where δa_{f0} and δa_{f1} , (see Table 20-X), are given in message types 34 or 13, and all other terms are as stated in 20.3.3.3.3.1 of IS-GPS-200. Clock-related DC data shall not be applied to any SV transmitting clock correction parameters message(s) containing a t_{op} value greater than the t_{op-D} value of messages types 34 or 13 containing the clock-related DC data.

20.3.3.7.4 Application of Orbit-Related Differential Correction Data. The DC data packet includes corrections to parameters that correct the state estimates for ephemeris parameters transmitted in the message types 10 and 11 (broadcast by the SV to which the DC data packet applies). The user will update the ephemeris parameters utilizing a variation of the algorithm expressed in the following equations. The user will then incorporate the updated quasi-Keplerian element set in all further calculations of SV position, as represented by the equations in Table 20-II (see para. 20.3.3.1.3). Ephemeris-related DC data shall not be applied to any SV transmitting message types 10 and 11 containing a t_{op} value greater than the t_{op-D} value of message types 34 or 14 containing the ephemeris-related DC data.

The user will construct a set of initial (uncorrected) elements by:

$$A_i = A_0$$

$$e_i = e_n$$

$$i_i = i_{0-n}$$

$$\Omega_i = \Omega_{0-n}$$

$$\alpha_i = e_n \cdot \cos(\omega_n)$$

$$\beta_i = e_n \cdot \sin(\omega_n)$$

$$\gamma_i = M_{0-n} + \omega_n$$

where A_0 , e_n , i_{0-n} , Ω_{0-n} , ω_n and M_{0-n} are obtained from the applicable SV's message types 10 and 11 data. The terms α_i , β_i , and γ_i form a subset of stabilized ephemeris elements which are subsequently corrected by $\Delta\alpha$, $\Delta\beta$ and $\Delta\gamma$ —the values of which are supplied in the message types 34 or 14—as follows:

$$\alpha_c = \alpha_i + \Delta\alpha$$

$$\beta_c = \beta_i + \Delta\beta$$

$$\gamma_c = \gamma_i + \Delta\gamma$$

The quasi-Keplerian elements are then corrected by

$$A_c = A_i + \Delta A$$

$$e_c = (\alpha_c^2 + \beta_c^2)^{1/2}$$

$$i_c = \frac{i_i + \Delta i}{i_0 + \Delta i}$$

$$\Omega_c = \frac{\Omega_i + \Delta\Omega}{\Omega_0 + \Delta\Omega}$$

$$\omega_c = \tan^{-1}(\beta_c/\alpha_c)$$

$$M_{0_c} = \gamma_c - \omega_c + \Delta M_0$$

where ΔA , Δi and $\Delta\Omega$ are provided in the EDC data packet of the message type 34 or 14 and ΔM_0 is obtained from

$$\Delta M_0 = -3*(\mu^{1/2})/A_c^2*[(t_{oc}) - (t_{OD})].$$

The corrected quasi-Keplerian elements above are applied to the user algorithm for determination of antenna phase center position in Section 20.3.3.1.3, Table 20-II.

20.3.3.7.5 SV Differential Range Accuracy Estimates. The $UDRA_{op-D}$ and \dot{UDRA} shall give the differential user range accuracy for the SV. It must be noted that the two parameters provide estimated accuracy after both clock and ephemeris DC are applied. The $UDRA_{op-D}$ and \dot{UDRA} indices are signed, two's complement integers in the range of +15 to -16 and have the following relationship:

<u>Index Value</u>	<u>$UDRA_{op-D}$ (meters)</u>	<u>\dot{UDRA} (10^{-6} m/sec)</u>
15	6144.00 < $UDRA_{op-D}$ < 6144.00	
14	3072.00 < $UDRA_{op-D}$ ≤ 6144.00	3072.00
13	1536.00 < $UDRA_{op-D}$ ≤ 3072.00	1536.00
12	768.00 < $UDRA_{op-D}$ ≤ 1536.00	768.00
11	384.00 < $UDRA_{op-D}$ ≤ 768.00	384.00
10	192.00 < $UDRA_{op-D}$ ≤ 384.00	192.00
9	96.00 < $UDRA_{op-D}$ ≤ 192.00	96.00
8	48.00 < $UDRA_{op-D}$ ≤ 96.00	48.00
7	24.00 < $UDRA_{op-D}$ ≤ 48.00	24.00
6	13.65 < $UDRA_{op-D}$ ≤ 24.00	13.65
5	9.65 < $UDRA_{op-D}$ ≤ 13.65	9.65
4	6.85 < $UDRA_{op-D}$ ≤ 9.65	6.85
3	4.85 < $UDRA_{op-D}$ ≤ 6.85	4.85
2	3.40 < $UDRA_{op-D}$ ≤ 4.85	3.40
1	2.40 < $UDRA_{op-D}$ ≤ 3.40	2.40
0	1.70 < $UDRA_{op-D}$ ≤ 2.40	1.70
-1	1.20 < $UDRA_{op-D}$ ≤ 1.70	1.20
-2	0.85 < $UDRA_{op-D}$ ≤ 1.20	0.85
-3	0.60 < $UDRA_{op-D}$ ≤ 0.85	0.60
-4	0.43 < $UDRA_{op-D}$ ≤ 0.60	0.43
-5	0.30 < $UDRA_{op-D}$ ≤ 0.43	0.30
-6	0.21 < $UDRA_{op-D}$ ≤ 0.30	0.21
-7	0.15 < $UDRA_{op-D}$ ≤ 0.21	0.15
-8	0.11 < $UDRA_{op-D}$ ≤ 0.15	0.11
-9	0.08 < $UDRA_{op-D}$ ≤ 0.11	0.08
-10	0.06 < $UDRA_{op-D}$ ≤ 0.08	0.06
-11	0.04 < $UDRA_{op-D}$ ≤ 0.06	0.04
-12	0.03 < $UDRA_{op-D}$ ≤ 0.04	0.03
-13	0.02 < $UDRA_{op-D}$ ≤ 0.03	0.02
-14	0.01 < $UDRA_{op-D}$ ≤ 0.02	0.01
-15	$UDRA_{op-D}$ ≤ 0.01	0.005
-16	No accuracy prediction available—use at own risk	

For any time, t_k , other than t_{op-D} , $UDRA$ is found by,

$$UDRA = UDRA_{op-D} + \dot{UDRA} (t_k - t_{op-D})$$

20.3.3.8 Message Type 35 GPS/GNSS Time Offset. Message type 35, Figure 20-8, contains the GPS/Global Navigation Satellite System (GNSS) Time Offset (GGTO) parameters. The contents of message type 35 are defined below. The validity period of the GGTO shall be 1 day as a minimum.

20.3.3.8.1 GPS/GNSS Time Offset Parameter Content. Message Type 35 provides SV clock correction parameters (ref. Section 20.3.3.2) and also, shall contain the parameters related to correlating GPS time with other GNSS time.

Bits 155 through 157 of message type 35 shall identify the other GPS-like navigation system to which the offset data applies. The three bits are defined as follows;

- 000 = no data available,
- 001 = Galileo,
- 010 = GLONASS,
- 011 through 111 = reserved for other systems.

The number of bits, the scales factor (LSB), the ranges, and the units of the GGTO parameters are given in Table 20-XI. See Figure 20-8 for complete bit allocation in message type 35.

20.3.3.8.2 GPS and GNSS Time. The GPS/GNSS-time relationship is given by,

$$t_{\text{GNSS}} = t_{\text{E}} - (A_{0\text{GGTO}} + A_{1\text{GGTO}} (t_{\text{E}} - t_{\text{otGGTO}} + 604800 (WN - WN_{\text{otGGTO}}))) + A_{2\text{GGTO}} (t_{\text{E}} - t_{\text{otGGTO}} + 604800 (WN - WN_{\text{otGGTO}}))^2$$

where t_{GNSS} is in seconds, t_{E} and WN are as defined in Section 20.3.3.5.2.4 of IS-GPS-200, and the remaining parameters are as defined in Table 20-XI.

Table 20-XI. GPS/GNSS Time Offset Parameters					
Parameter		No. of Bits**	Scale Factor (LSB)	Effective Range***	Units
Parameter Symbol	Parameter Description	No. of Bits**	Scale Factor (LSB)	Effective Range***	Units
A _{0GGTO}	Bias coefficient of GPS time scale relative to GNSS time scale	16*	2 ⁻³⁵		seconds
A _{1GGTO}	Drift coefficient of GPS time scale relative to GNSS time scale	13*	2 ⁻⁵¹		sec/sec
A _{2GGTO}	Drift rate correction coefficient of GPS time scale relative to GNSS time scale	7*	2 ⁻⁶⁸		sec/sec ²
t _{oGGTO}	Time data reference Time of Week	146	2 ⁴⁶	604,7368	seconds
WN _{oGGTO}	Time data reference Week Number	13	2 ⁰	4	weeks
GNSS ID	GNSS Type ID	3			see text

* Parameters so indicated shall be two's complement with the sign bit (+ or -) occupying the MSB;

** See Figure 20-8 for complete bit allocation;

*** Unless otherwise indicated in this column, effective range is the maximum range attainable with indicated bit allocation and scale factor.

20.3.3.9 Message Types 36 and 15 Text Messages. Text messages are provided either in message type 36, Figure 20-9, or type 15, Figure 20-14. The specific contents of text message will be at the discretion of the Operating Command. Message type 36 can accommodate the transmission of 18 eight-bit ASCII characters. Message type 15 can accommodate the transmission of 29 eight-bit ASCII characters. The requisite bits shall occupy bits 39 through 274 of message type 15 and bits 128 through 275 of message type 36. The eight-bit ASCII characters shall be limited to the set described in paragraph 20.3.3.5.1.8 of IS-GPS-200.

20.3.4 Timing Relationships. The following conventions shall apply.

20.3.4.1 Paging and Cutovers. Broadcast system of messages is completely arbitrary, but sequenced to provide optimum user performance. Message types 10 and 11 shall be broadcast at least once every 24 seconds. All other

messages shall be broadcast in-between, not exceeding the maximum broadcast interval in Table 20-XII. Message type 15 will be broadcast as needed, but will not reduce the maximum broadcast interval of the other messages. Type 15 messages that are longer than one page will not necessarily be broadcast consecutively.

Table 20- XII. Message Broadcast Intervals		
Message Data	Message Type Number	Maximum Broadcast Intervals [†]
Ephemeris	10 & 11	24 sec
Clock	Type 30-37	24 sec
ISC, IONO	30 *	144 sec
Reduced Almanac	31* or 12	10 min**
Midi Almanac	37	60 min**
EOP	32*	15 min
UTC	33*	144 sec
Diff Correction	34* or 13 & 14	15 min***
GGTO	35*	144 sec
Text	36* or 15	As needed
<p>* Also contains SV clock correction parameters. ** Complete set of SVs in the constellation. *** When Differential Corrections are available. [†] The intervals specified are maximum. As such, the broadcast intervals may be shorter than the specified value.</p>		

20.3.4.2 SV Time vs. GPS Time. In controlling the SVs and uploading of data, the CS shall allow for the following timing relationships:

- a. Each SV operates on its own SV time;
- b. All time-related data (TOW) in the messages shall be in SV-time;
- c. All other data in the NAV message shall be relative to GPS time;
- d. The acts of transmitting the NAV messages shall be executed by the SV on SV time.

20.3.4.3 Speed of Light. The speed of light used by the CS for generating the data described in the above paragraphs is

$$c = 2.99792458 \times 10^8 \quad \text{meters per second}$$

which is the official ~~WGS 84~~WGS 84 speed of light. The user shall use the same value for the speed of light in all computations.

20.3.5 Data Frame Parity. The data signal contains parity coding according to the following conventions.

20.3.5.1 Parity Algorithm. Twenty-four bits of CRC parity will provide protection against burst as well as random errors with a probability of undetected error $\leq 2^{-24} = 5.96 \times 10^{-8}$ for all channel bit error probabilities ≤ 0.5 . The CRC word is calculated in the forward direction on a given message using a seed of 0. The sequence of 24 bits $(p_1, p_2, \dots, p_{24})$ is generated from the sequence of information bits $(m_1, m_2, \dots, m_{276})$ in a given message. This is done by means of a code that is generated by the polynomial.

$$g(X) = \sum_{i=0}^{24} g_i X^i$$

where

$$g_i = 1 \text{ for } i = 0, 1, 3, 4, 5, 6, 7, 10, 11, 14, 17, 18, 23, 24 \\ = 0 \text{ otherwise}$$

This code is called CRC-24Q. The generator polynomial of this code is in the following form (using binary polynomial algebra):

$$g(X) = (1 + X)p(X)$$

where $p(X)$ is the primitive and irreducible polynomial

$$p(X) = X^{23} + X^{17} + X^{13} + X^{12} \\ + X^{11} + X^9 + X^8 + X^7 + X^5 + X^3 + 1$$

When, by the application of binary polynomial algebra, the above $g(X)$ is divided into $m(X)X^{24}$, where the information sequence $m(X)$ is expressed as

$$m(X) = m_k + m_{k-1}X + m_{k-2}X^2 + \dots + m_1X^{k-1}$$

The result is a quotient and a remainder $R(X)$ of degree < 24 . The bit sequence formed by this remainder represents the parity check sequence. Parity bit p_i , for any i from 1 to 24, is the coefficient of X^{24-i} in $R(X)$.

This code has the following characteristics:

- 1) It detects all single bit errors per code word.
- 2) It detects all double bit error combinations in a codeword because the generator polynomial $g(X)$ has a factor of at least three terms.
- 3) It detects any odd number of errors because $g(X)$ contains a factor $1+X$.
- 4) It detects any burst error for which the length of the burst is ≤ 24 bits.
- 5) It detects most large error bursts with length greater than the parity length $r = 24$ bits. The fraction of error bursts of length $b > 24$ that are undetected is:

a) $2^{-24} = 5.96 \times 10^{-8}$, if $b > 25$ bits.

b) $2^{-23} = 1.19 \times 10^{-7}$, if $b = 25$ bits.