

CHANGE NOTICE

Affected Document: IS-GPS-200 Rev N	IRN/SCN Number IRN-IS-200N-003	Date: 27-SEP-2023
Authority: RFC-00502	Proposed Change Notice PCN- IS-200N_RFC502	Date: 31-MAY-2023
Document Title: NAVSTAR GPS Space Segment/Navigation User Segment Interfaces		
RFC Title: 2023 Proposed Changes to the Public Documents		
Reason For Change (Driver): <ol style="list-style-type: none">1. Finalize the CNAV Schedules Technical Baseline changes2. Resolve the Data ID Issue (a commercial vendor did not want Data IDs other than 2)3. Add the maximum power for GPS III/IIIF SVs to IS-GPS-2004. Accommodate all administrative fixes possible from Boeing's list of fixes		
Description of Change: <p>Make updates to public documents IS-GPS-200, IS-GPS-705 and IS-GPS-800 as appropriate</p> <ol style="list-style-type: none">1. Update the CNAV message schedule information2. Publish the resolution for the Data ID Issue to IS-GPS-2003. Add the maximum power for GPS III/IIIF SVs to IS-GPS-2004. Fix the three figures that have the most readability problems		
Authored By: RE: Tony Anthony		Checked By: RE: Emily Hendrickson
AUTHORIZED SIGNATURES	REPRESENTING	DATE
DUNN.MICHAEL.J.11 71235045 <small>Digitally signed by DUNN.MICHAEL.J.1171235045 Date: 2024.01.19 11:22:56 -0800</small>	PNT Technical Director, MilComm & PNT Directorate, Space Systems Command (SSC)	19-JAN-2024
DISTRIBUTION STATEMENT A: Approved for Public Release; Distribution Is Unlimited		
THIS DOCUMENT SPECIFIES TECHNICAL REQUIREMENTS AND NOTHING HEREIN CONTAINED SHALL BE DEEMED TO ALTER THE TERMS OF ANY CONTRACT OR PURCHASE ORDER BETWEEN ALL PARTIES AFFECTED.		Interface Control Contractor: SAIC (GPS SE&I) 200 N. Pacific Coast Highway, Suite 1800 El Segundo, CA 90245 CODE IDENT 66RP1

IS200-25:

Section Number:

3.2.1.1.0-1

WAS:

The PRN P-code for SV ID number i , for $i = 1$ to 37, is a ranging code, $P_i(t)$, of 7 days in length at a chipping rate of 10.23 Mbps. The 7 day sequence is the modulo-2 sum of two sub-sequences referred to as X1 and X2 _{i} ; their lengths are 15,345,000 chips and 15,345,037 chips, respectively. The X2 _{i} sequence is an X2 sequence selectively delayed by 1 to 37 chips thereby allowing the basic code generation technique to produce a set of 37 mutually exclusive P-code sequences of 7 days in length. Assignment of these code phase segments by SV ID number is given in Table 3-Ia. (NOTE: previous versions of this document reserved PRNs 33 through 37 for other uses. Due to increased system capability, PRNs 33 through 37 are being redesignated to allow for use by SVs.)

An initial almanac collected from P(Y)-code in the upper PRNs must be obtained from PRNs 35, 36, or 38 through 63.

Redlines:

The PRN P-code for SV ID number i , for $i = 1$ to 37, is a ranging code, $P_i(t)$, of 7 days in length at a chipping rate of 10.23 Mbps. The 7 day sequence is the modulo-2 sum of two sub-sequences referred to as X1 and X2 _{i} ; their lengths are 15,345,000 chips and 15,345,037 chips, respectively. The X2 _{i} sequence is an X2 sequence selectively delayed by 1 to 37 chips thereby allowing the basic code generation technique to produce a set of 37 mutually exclusive P-code sequences of 7 days in length. Assignment of these code phase segments by SV ID number is given in Table 3-Ia. (NOTE: previous versions of this document reserved PRNs 33 through 37 for other uses. Due to increased system capability, PRNs 33 through 37 are being redesignated to allow for use by SVs.)

~~An initial almanac collected from P(Y)-code in the upper PRNs must be obtained from PRNs 35, 36, or 38 through 63.~~

IS:

The PRN P-code for SV ID number i , for $i = 1$ to 37, is a ranging code, $P_i(t)$, of 7 days in length at a chipping rate of 10.23 Mbps. The 7 day sequence is the modulo-2 sum of two sub-sequences referred to as X1 and X2 _{i} ; their lengths are 15,345,000 chips and 15,345,037 chips, respectively. The X2 _{i} sequence is an X2 sequence selectively delayed by 1 to 37 chips thereby allowing the basic code generation technique to produce a set of 37 mutually exclusive P-code sequences of 7 days in length. Assignment of these code phase segments by SV ID number is given in Table 3-Ia. (NOTE: previous versions of this document reserved PRNs 33 through 37 for other uses. Due to increased system capability, PRNs 33 through 37 are being redesignated to allow for use by SVs.)

IS200-29:

Section Number:

3.2.1.3.0-1

WAS:

The PRN C/A-code for SV ID number i is a Gold code, $G_i(t)$, of 1 millisecond in length at a chipping rate of 1023 kbps. The $G_i(t)$ sequence is a linear pattern generated by the modulo-2 addition of two sub-sequences, G_1 and G_{2i} , each of which is a 1023 chip long linear pattern. The epochs of the Gold code are synchronized with the X1 epochs of the P-code. As shown in Table 3-Ia, the G_{2i} sequence is a G_2 sequence selectively delayed by pre-assigned number of chips, thereby generating a set of different C/A-codes. Assignment of these by GPS PRN signal number are given in Table 3-Ia and Table 3-Ib.

An initial almanac collected from C/A-code in the upper PRNs must be obtained from PRNs 35, 36, or 38 through 63.

CS *will prevent* the simultaneous transmission of PRNs 34 and 37 of C/A-code.

Redlines:

The PRN C/A-code for SV ID number i is a Gold code, $G_i(t)$, of 1 millisecond in length at a chipping rate of 1023 kbps. The $G_i(t)$ sequence is a linear pattern generated by the modulo-2 addition of two sub-sequences, G_1 and G_{2i} , each of which is a 1023 chip long linear pattern. The epochs of the Gold code are synchronized with the X1 epochs of the P-code. As shown in Table 3-Ia, the G_{2i} sequence is a G_2 sequence selectively delayed by pre-assigned number of chips, thereby generating a set of different C/A-codes. Assignment of these by GPS PRN signal number are given in Table 3-Ia and Table 3-Ib.

~~An initial almanac collected from C/A-code in the upper PRNs must be obtained from PRNs 35, 36, or 38 through 63.~~

CS will prevent the simultaneous transmission of PRNs 34 and 37 of C/A-code ~~to any point on the Earth's surface.~~

IS:

The PRN C/A-code for SV ID number i is a Gold code, $G_i(t)$, of 1 millisecond in length at a chipping rate of 1023 kbps. The $G_i(t)$ sequence is a linear pattern generated by the modulo-2 addition of two sub-sequences, G_1 and G_{2i} , each of which is a 1023 chip long linear pattern. The epochs of the Gold code are synchronized with the X1 epochs of the P-code. As shown in Table 3-Ia, the G_{2i} sequence is a G_2 sequence selectively delayed by pre-assigned number of chips, thereby generating a set of different C/A-codes. Assignment of these by GPS PRN signal number are given in Table 3-Ia and Table 3-Ib.

CS *will prevent* the simultaneous transmission of PRNs 34 and 37 of C/A-code to any point on the Earth's surface.

Section Number:

3.3.2.4.0-3

WAS:

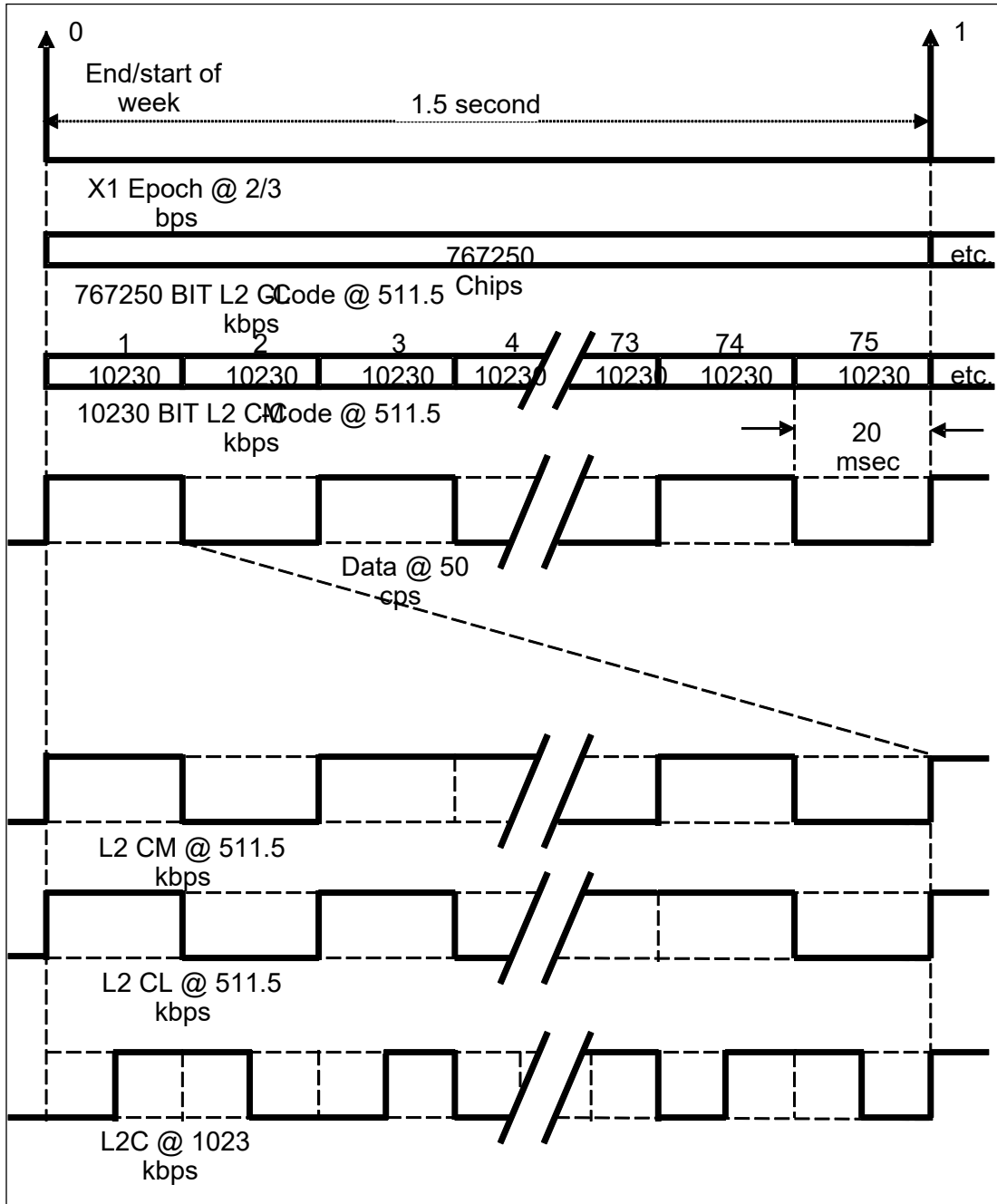

Redlines: <not available graphically>

- Reworked the line beginning with “767250 BIT...” so text is no longer crowded
- Reworked the line beginning with “10230 BIT...” so text is no longer crowded

IS:

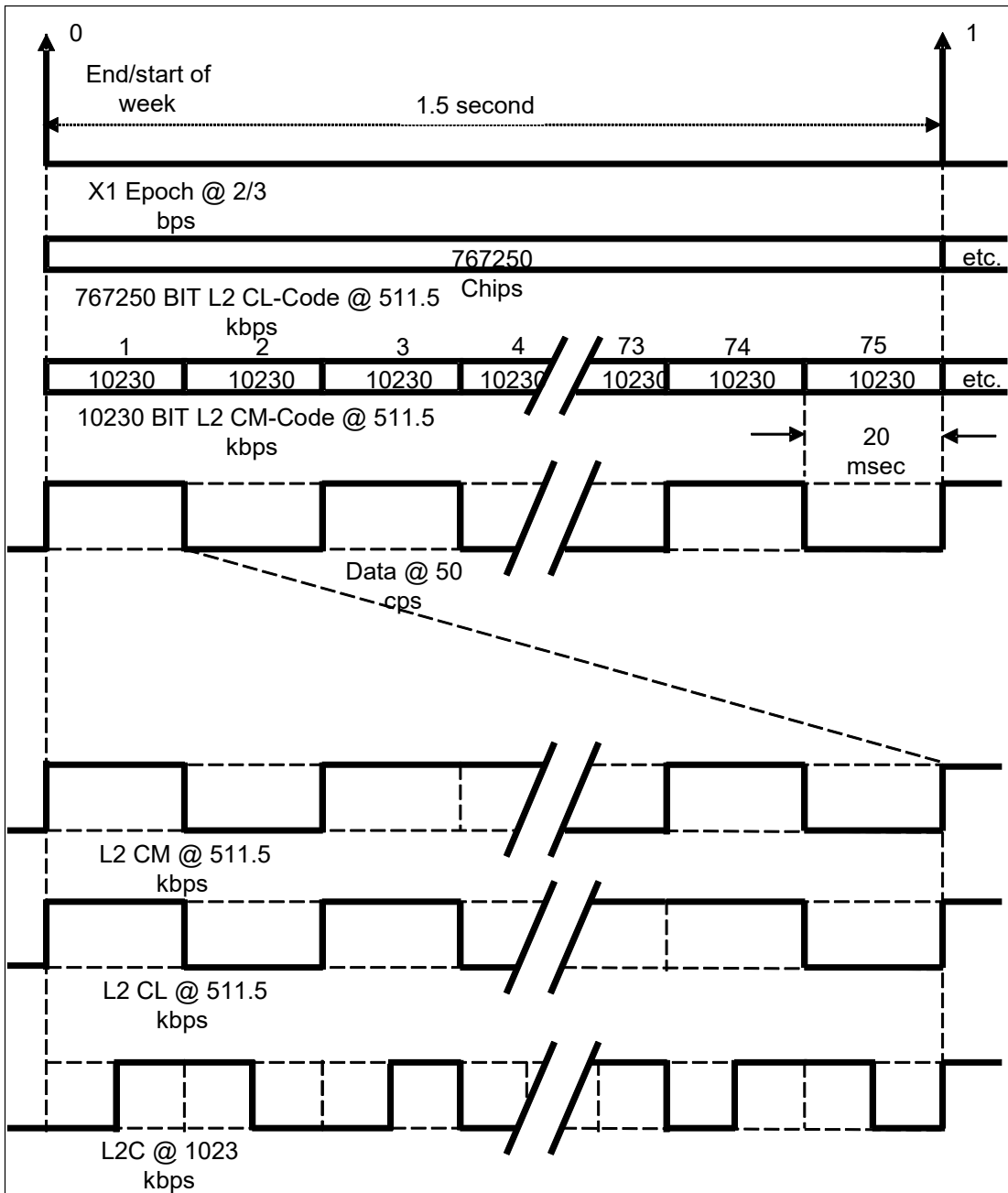

IS200-144:

Section Number:

3.3.3.1.1.0-7

WAS:

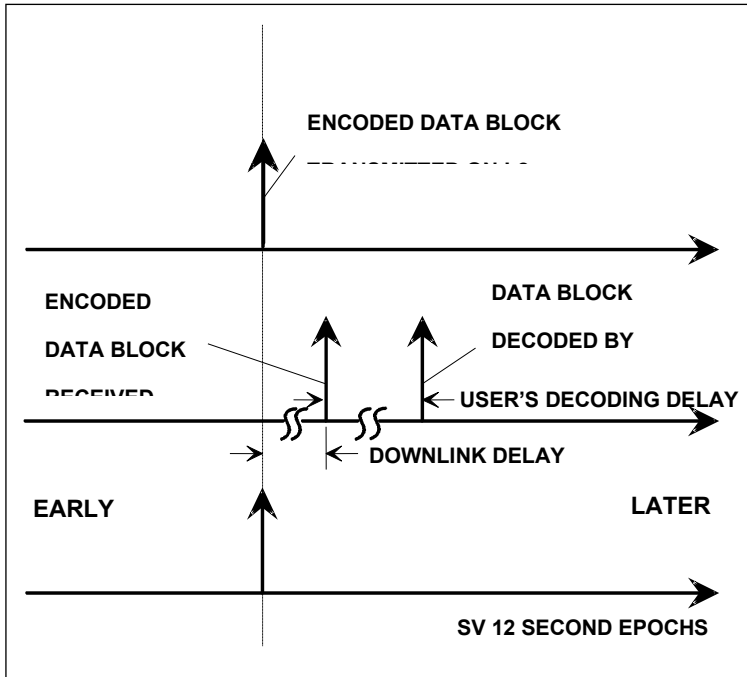

Redlines: <not available graphically>

- Repaired the spacing on three text blocks to ensure they are single spaced so all lines of text can be seen

IS:

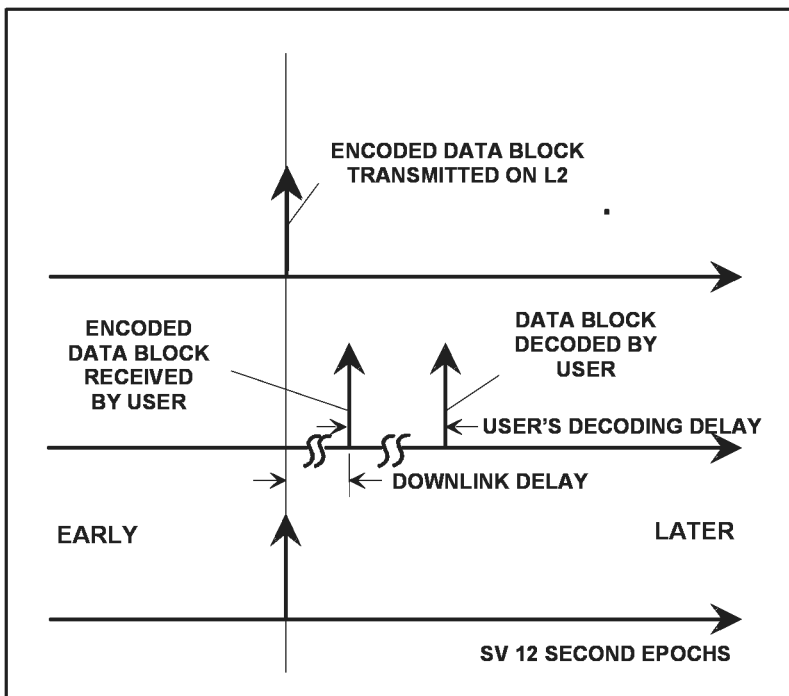

IS200-1488:

Section Number:

6.1.0-1

WAS:

AI	-	Availability Indicator
AODO	-	Age of Data Offset
ARAIM	-	Advanced Receiver Autonomous Integrity Monitoring
A-S	-	Anti-Spoofing
BPSK	-	Bi-Phase Shift Key
CDC	-	Clock Differential Correction
CEI	-	Clock, Ephemeris, Integrity
CNAV	-	Civil Navigation
cps	-	cycles per second
CRC	-	Cyclic Redundancy Check
CS	-	Control Segment
DC	-	Differential Correction
dBc	-	Power ratio of a signal to a (unmodulated) carrier signal, expressed in decibels
dBi	-	Decibel with respect to isotropic antenna
dBW	-	Decibel with respect to 1 W
DN	-	Day Number
EAROM	-	Electrically Alterable Read-Only Memory
ECEF	-	Earth-Centered, Earth-Fixed
ECI	-	Earth-Centered, Inertial
EDC	-	Ephemeris Differential Correction
EOE	-	Edge-of-Earth
EOL	-	End of Life
ERD	-	Estimated Range Deviation
FEC	-	Forward Error Correction

GGTO	-	GPS/GNSS Time Offset
GNSS	-	Global Navigation Satellite System
GPS	-	Global Positioning System
GPSW	-	Global Positioning System Wing
HOW	-	Hand-Over Word
ICC	-	Interface Control Contractor
ID	-	Identification
IERS	-	International Earth Rotation and Reference Systems Service
IODC	-	Issue of Data, Clock
IODE	-	Issue of Data, Ephemeris
IRM	-	IERS Reference Meridian
IRP	-	IERS Reference Pole
IS	-	Interface Specification
ISC	-	Inter-Signal Correction
ISM	-	Integrity Support Message
LNAV	-	Legacy Navigation
LSB	-	Least Significant Bit
LSF	-	Leap Seconds Future
L2C	-	L2 Civil Signal
L2 CL	-	L2 Civil-Long Code
L2 CM	-	L2 Civil-Moderate Code
MCS	-	Master Control Station
MSB	-	Most Significant Bit
MSO	-	Military Standard Order
NAV	-	Navigation
NDUS	-	NUDET Detection User Segment
NMCT	-	Navigation Message Correction Table
NSC	-	Non-Standard C/A-Code
NSCL	-	Non-Standard L2 CL-Code

NSCM	-	Non-Standard L2 CM-Code
NSY	-	Non-Standard Y-Code
OBCP	-	On-Board Computer Program
OCS	-	Operational Control System
PPS	-	Precise Positioning Service
PRN	-	Pseudo-Random Noise
RAIM	-	Receiver Autonomous Integrity Monitoring
RF	-	Radio Frequency
RMS	-	Root Mean Square
SA	-	Selective Availability
SBAS	-	Satellite-Based Augmentation System
SEP	-	Spherical Error Probable
SPS	-	Standard Positioning Service
sps	-	symbols per second
SS	-	Space Segment
SSV	-	Space Service Volume
SV	-	Space Vehicle
SVN	-	Space Vehicle Number
TBD	-	To Be Determined
TBS	-	To Be Supplied
TLM	-	Telemetry
TSO	-	Technical Standard Order
TOW	-	Time Of Week
UE	-	User Equipment
URA	-	User Range Accuracy
URE	-	User Range Error
US	-	User Segment
USNO	-	U.S. Naval Observatory
UTC	-	Coordinated Universal Time

WGS 84	-	World Geodetic System 1984
WN	-	Data Sequence Propagation Week Number
WN _e	-	Extended Week Number

Redlines:

AI	-	Availability Indicator
AODO	-	Age of Data Offset
ARAIM	-	Advanced Receiver Autonomous Integrity Monitoring
A-S	-	Anti-Spoofing
BPSK	-	Bi-Phase Shift Key
CDC	-	Clock Differential Correction
CEI	-	Clock, Ephemeris, Integrity
CNAV	-	Civil Navigation
cps	-	cycles per second
CRC	-	Cyclic Redundancy Check
CS	-	Control Segment
DC	-	Differential Correction
dBc	-	Power ratio of a signal to a (unmodulated) carrier signal, expressed in decibels
dBi	-	Decibel with respect to isotropic antenna
dBW	-	Decibel with respect to 1 W
DN	-	Day Number
EAROM	-	Electrically Alterable Read-Only Memory
ECEF	-	Earth-Centered, Earth-Fixed
ECI	-	Earth-Centered, Inertial
EDC	-	Ephemeris Differential Correction
EOE	-	Edge-of-Earth
EOL	-	End of Life
ERD	-	Estimated Range Deviation
FEC	-	Forward Error Correction
GGTO	-	GPS/GNSS Time Offset
GNSS	-	Global Navigation Satellite System
GPS	-	Global Positioning System
GPSW	-	Global Positioning System Wing

HOW	-	Hand-Over Word
ICC	-	Interface Control Contractor
ID	-	Identification
IERS	-	International Earth Rotation and Reference Systems Service
IODC	-	Issue of Data, Clock
IODE	-	Issue of Data, Ephemeris
IRM	-	IERS Reference Meridian
IRP	-	IERS Reference Pole
IS	-	Interface Specification
ISC	-	Inter-Signal Correction
ISM	-	Integrity Support Message
LNAV	-	Legacy Navigation
LSB	-	Least Significant Bit
LSF	-	Leap Seconds Future
L2C	-	L2 Civil Signal
L2 CL	-	L2 Civil-Long Code
L2 CM	-	L2 Civil-Moderate Code
MCS	-	Master Control Station
MSB	-	Most Significant Bit
MSO	-	Military Standard Order
NAV	-	Navigation
NDUS	-	NUDET Detection User Segment
NMCT	-	Navigation Message Correction Table
NSC	-	Non-Standard C/A-Code
NSCL	-	Non-Standard L2 CL-Code
NSCM	-	Non-Standard L2 CM-Code
NSY	-	Non-Standard Y-Code
OBCP	-	On-Board Computer Program
OCS	-	Operational Control System

PPS	-	Precise Positioning Service
PRN	-	Pseudo-Random Noise
RAIM	-	Receiver Autonomous Integrity Monitoring
RF	-	Radio Frequency
RMS	-	Root Mean Square
SA	-	Selective Availability
SBAS	-	Satellite-Based Augmentation System
SEP	-	Spherical Error Probable
SPS	-	Standard Positioning Service
sps	-	symbols per second
SS	-	Space Segment
SSV	-	Space Service Volume
SV	-	Space Vehicle
SVN	-	Space Vehicle Number
TBD	-	To Be Determined
TBS	-	To Be Supplied
TLM	-	Telemetry
TSO	-	Technical Standard Order
TOW	-	Time Of Week
UE	-	User Equipment
URA	-	User Range Accuracy
URE	-	User Range Error
US	-	User Segment
USNO	-	U.S. Naval Observatory
UTC	-	Coordinated Universal Time
WGS 84	-	World Geodetic System 1984
WN	-	Data Sequence Propagation Week Number
WN_e	-	Extended Week Number

IS:

AI	-	Availability Indicator
AODO	-	Age of Data Offset
ARAIM	-	Advanced Receiver Autonomous Integrity Monitoring
A-S	-	Anti-Spoofing
BPSK	-	Bi-Phase Shift Key
CDC	-	Clock Differential Correction
CEI	-	Clock, Ephemeris, Integrity
CNAV	-	Civil Navigation
cps	-	cycles per second
CRC	-	Cyclic Redundancy Check
CS	-	Control Segment
DC	-	Differential Correction
dBc	-	Power ratio of a signal to a (unmodulated) carrier signal, expressed in decibels
dBi	-	Decibel with respect to isotropic antenna
dBW	-	Decibel with respect to 1 W
DN	-	Day Number
EAROM	-	Electrically Alterable Read-Only Memory
ECEF	-	Earth-Centered, Earth-Fixed
ECI	-	Earth-Centered, Inertial
EDC	-	Ephemeris Differential Correction
EOE	-	Edge-of-Earth
EOL	-	End of Life
ERD	-	Estimated Range Deviation
FEC	-	Forward Error Correction
GGTO	-	GPS/GNSS Time Offset
GNSS	-	Global Navigation Satellite System
GPS	-	Global Positioning System
GPSW	-	Global Positioning System Wing

HOW	-	Hand-Over Word
ICC	-	Interface Control Contractor
ID	-	Identification
IERS	-	International Earth Rotation and Reference Systems Service
IODC	-	Issue of Data, Clock
IODE	-	Issue of Data, Ephemeris
IRM	-	IERS Reference Meridian
IRP	-	IERS Reference Pole
IS	-	Interface Specification
ISC	-	Inter-Signal Correction
ISM	-	Integrity Support Message
LNAV	-	Legacy Navigation
LSB	-	Least Significant Bit
LSF	-	Leap Seconds Future
L2C	-	L2 Civil Signal
L2 CL	-	L2 Civil-Long Code
L2 CM	-	L2 Civil-Moderate Code
MCS	-	Master Control Station
MSB	-	Most Significant Bit
MSO	-	Military Standard Order
NAV	-	Navigation
NDUS	-	NUDET Detection User Segment
NMCT	-	Navigation Message Correction Table
NSC	-	Non-Standard C/A-Code
NSCL	-	Non-Standard L2 CL-Code
NSCM	-	Non-Standard L2 CM-Code
NSY	-	Non-Standard Y-Code
OBCP	-	On-Board Computer Program
OCS	-	Operational Control System

PPS	-	Precise Positioning Service
PRN	-	Pseudo-Random Noise
RAIM	-	Receiver Autonomous Integrity Monitoring
RF	-	Radio Frequency
RMS	-	Root Mean Square
SA	-	Selective Availability
SBAS	-	Satellite-Based Augmentation System
SEP	-	Spherical Error Probable
SPS	-	Standard Positioning Service
sps	-	symbols per second
SS	-	Space Segment
SSV	-	Space Service Volume
SV	-	Space Vehicle
SVN	-	Space Vehicle Number
TBD	-	To Be Determined
TBS	-	To Be Supplied
TLM	-	Telemetry
TSO	-	Technical Standard Order
TOW	-	Time Of Week
UE	-	User Equipment
URA	-	User Range Accuracy
URE	-	User Range Error
US	-	User Segment
USNO	-	U.S. Naval Observatory
UTC	-	Coordinated Universal Time
WGS 84	-	World Geodetic System 1984

IS200-1508:

Section Number:

6.2.7.0-1

WAS:

Valid Range identifies the range of values used by GPS. The Valid Range is only for PRNs 1-63.

Redlines:

Valid Range identifies the range of values [of parameters](#) used by GPS. ~~The Valid Range is in only the for specified PRNs data 1-63 format.~~

IS:

Valid Range identifies the range of values of parameters used by GPS in the specified data format.

IS200-1649:

Section Number:

6.2.9.1.0-1

WAS:

A Core CEI Data Set are the CEI parameters necessary for a satellite to be used for a position solution (non-almanac); broadcast to users with the shortest broadcast interval -- see Table 30-XII. The t_{op} term provides the epoch time of week of the state data utilized for CEI data, except for parameters marked with a NOTE1 in Table 6-I-1.

Redlines:

A Core CEI Data Set are the CEI parameters necessary for a satellite to be used for a position solution (non-almanac); broadcast to users with the shortest broadcast interval [for CNAV](#) -- see ~~Table 30-XII.3.4.1~~. The top term provides the epoch time of week of the state data utilized for CEI data, except for parameters marked with a NOTE1 in Table 6-I-1.

IS:

A Core CEI Data Set are the CEI parameters necessary for a satellite to be used for a position solution (non-almanac); broadcast to users with the shortest broadcast interval for CNAV -- see 30.3.4.1. The t_{op} term provides the epoch time of week of the state data utilized for CEI data, except for parameters marked with a NOTE1 in Table 6-I-1.

IS200-1639:

Section Number:

6.2.9.1-2

WAS:

Symbol	Parameter Name	Subframe	Message
SV Health	SV Health (6 bits)	1	N/A
IODC	Issue of Data, Clock	1	N/A
URA	URA Index	1	N/A
WN	Data Sequence Propagation Week Number	1	10
T _{GD}	Group Delay Differential	1	30
a _{f0}	SV Clock Bias Correction Coefficient	1	30-37
a _{f1}	SV Clock Drift Correction Coefficient	1	30-37
a _{f2}	Drift Rate Correction Coefficient	1	30-37
t _{oc}	Time of Clock	1	30-37
\sqrt{A}	Square Root of the Semi-Major Axis	2	N/A
Δn	Mean Motion Difference from Computed Value	2	N/A
Fit Interval Flag	Fit Interval Flag	2	N/A
e	Eccentricity	2	10
M ₀	Mean Anomaly at Reference Time	2	10
t _{oe}	Time of Ephemeris	2	10, 11
C _{rs}	Amplitude of the Sine Correction Term to the Orbit Radius	2	11
C _{uc}	Amplitude of Cosine Harmonic Correction Term to the Argument of Latitude	2	11
C _{us}	Amplitude of Sine Harmonic Correction Term to the Argument of Latitude	2	11
IODE	Issue of Data, Ephemeris	2, 3	N/A
ISF	Integrity Status Flag ^{NOTE1}	All	10
ω	Argument of Perigee	3	10
$\dot{\Omega}$	Rate of Right Ascension	3	N/A
$\Delta\dot{\Omega}$	Rate of Right Ascension Difference	N/A	11
Ω_0	Longitude of Ascending Node of Orbit Plane at Weekly Epoch	3	11
i ₀	Inclination Angle at Reference Time	3	11
IDOT	Rate of Inclination Angle	3	11
C _{ic}	Amplitude of the Cosine Harmonic Correction Term to the Angle of Inclination	3	11
C _{is}	Amplitude of the Sine Harmonic Correction Term to the Angle of Inclination	3	11

Symbol	Parameter Name	Subframe	Message
C_{rc}	Amplitude of the Cosine Harmonic Correction Term to the Orbit Radius	3	11
ΔA	Semi-major Axis Difference at Reference Time	N/A	10
\dot{A}	Change Rate in Semi-major Axis	N/A	10
Δn_0	Mean Motion Difference from Computed Value at Reference Time	N/A	10
$\Delta \dot{n}_0$	Rate of Mean Motion Difference from Computed Value	N/A	10
(L1/L2/L5)	Signal Health (3 bits)	N/A	10
URA _{ED}	Elevation Dependent User Range Accuracy	N/A	10
ISC _{L1C/A}	Inter-signal Correction	N/A	30
ISC _{L2C}	Inter-signal Correction	N/A	30
ISC _{L5I5}	Inter-signal Correction	N/A	30
ISC _{L5Q5}	Inter-signal Correction	N/A	30
t_{op}	CEI Data Sequence Propagation Time of Week	N/A	10, 30-37
URA _{NED0}	NED Accuracy Index	N/A	30-37
URA _{NED1}	NED Accuracy Change Index	N/A	30-37
URA _{NED2}	NED Accuracy Change Rate Index	N/A	30-37
Alert	Alert Flag ^{NOTE1}	All	All
<p>NOTE1: Parameters so indicated are for CEI Refinement – not limited to curve fit. Parameters not indicated are needed for/limited to curve fit.</p> <p>Updates to parameters in table shall prompt changes in t_{oe}/t_{oc} for CNAV and $t_{oe}/t_{oc}/IODC/IODE$ for LNAV. Any parameter marked with NOTE1 may be changed with or without a change in $t_{oe}/t_{oc}/IODC/IODE$.</p>			

Redlines:

Symbol	Parameter Name	Subframe	Message
SV Health	SV Health (6 bits)	1	N/A
IODC	Issue of Data, Clock	1	N/A
URA	URA Index	1	N/A
WN	Data Sequence Propagation Week Number	1	10
T _{GD}	Group Delay Differential	1	30
<u>WN_{OP}</u>	<u>CEI Data Sequence Propagation Week Number</u>	<u>N/A</u>	<u>30</u>
a _{f0}	SV Clock Bias Correction Coefficient	1	30-37
a _{f1}	SV Clock Drift Correction Coefficient	1	30-37
a _{f2}	Drift Rate Correction Coefficient	1	30-37
t _{oc}	Time of Clock	1	30-37
\sqrt{A}	Square Root of the Semi-Major Axis	2	N/A
Δn	Mean Motion Difference from Computed Value	2	N/A
Fit Interval Flag	Fit Interval Flag	2	N/A
e	Eccentricity	2	10
M ₀	Mean Anomaly at Reference Time	2	10
t _{oe}	Time of Ephemeris	2	10, 11
C _{rs}	Amplitude of the Sine Correction Term to the Orbit Radius	2	11
C _{uc}	Amplitude of Cosine Harmonic Correction Term to the Argument of Latitude	2	11
C _{us}	Amplitude of Sine Harmonic Correction Term to the Argument of Latitude	2	11
IODE	Issue of Data, Ephemeris	2, 3	N/A
ISF	Integrity Status Flag ^{NOTE1}	All	10
ω	Argument of Perigee	3	10
$\dot{\Omega}$	Rate of Right Ascension	3	N/A
$\Delta\dot{\Omega}$	Rate of Right Ascension Difference	N/A	11
Ω_0	Longitude of Ascending Node of Orbit Plane at Weekly Epoch	3	11
i ₀	Inclination Angle at Reference Time	3	11
IDOT	Rate of Inclination Angle	3	11
C _{ic}	Amplitude of the Cosine Harmonic Correction Term to the Angle of Inclination	3	11
C _{is}	Amplitude of the Sine Harmonic Correction Term to the Angle of Inclination	3	11
C _{rc}	Amplitude of the Cosine Harmonic Correction Term to the Orbit Radius	3	11
ΔA	Semi-major Axis Difference at Reference Time	N/A	10

Symbol	Parameter Name	Subframe	Message
\dot{A}	Change Rate in Semi-major Axis	N/A	10
Δn_0	Mean Motion Difference from Computed Value at Reference Time	N/A	10
$\Delta \dot{n}_0$	Rate of Mean Motion Difference from Computed Value	N/A	10
(L1/L2/L5)	Signal Health (3 bits)	N/A	10
URA _{ED}	Elevation Dependent User Range Accuracy	N/A	10
ISC _{L1C/A}	Inter-signal Correction	N/A	30
ISC _{L2C}	Inter-signal Correction	N/A	30
ISC _{L5I5}	Inter-signal Correction	N/A	30
ISC _{L5Q5}	Inter-signal Correction	N/A	30
t _{op}	CEI Data Sequence Propagation Time of Week	N/A	10, 30-37
URA _{NED0}	NED Accuracy Index	N/A	30-37
URA _{NED1}	NED Accuracy Change Index	N/A	30-37
URA _{NED2}	NED Accuracy Change Rate Index	N/A	30-37
Alert	Alert Flag ^{NOTE1}	All	All

NOTE1: Parameters so indicated are for CEI Refinement – not limited to curve fit. Parameters not indicated are needed for/limited to curve fit.

Updates to parameters in table shall prompt changes in t_{oe}/t_{oc} for CNAV and t_{oe}/t_{oc}/IODC/IODE for LNAV. Any parameter marked with NOTE1 may be changed with or without a change in t_{oe}/t_{oc}/IODC/IODE.

IS:

Symbol	Parameter Name	Subframe	Message
SV Health	SV Health (6 bits)	1	N/A
IODC	Issue of Data, Clock	1	N/A
URA	URA Index	1	N/A
WN	Week Number	1	10
T_{GD}	Group Delay Differential	1	30
WN_{OP}	CEI Data Sequence Propagation Week Number	N/A	30
a_{f0}	SV Clock Bias Correction Coefficient	1	30-37
a_{f1}	SV Clock Drift Correction Coefficient	1	30-37
a_{f2}	Drift Rate Correction Coefficient	1	30-37
t_{oc}	Time of Clock	1	30-37
\sqrt{A}	Square Root of the Semi-Major Axis	2	N/A
Δn	Mean Motion Difference from Computed Value	2	N/A
Fit Interval Flag	Fit Interval Flag	2	N/A
e	Eccentricity	2	10
M_0	Mean Anomaly at Reference Time	2	10
t_{oe}	Time of Ephemeris	2	10, 11
C_{rs}	Amplitude of the Sine Correction Term to the Orbit Radius	2	11
C_{uc}	Amplitude of Cosine Harmonic Correction Term to the Argument of Latitude	2	11
C_{us}	Amplitude of Sine Harmonic Correction Term to the Argument of Latitude	2	11
IODE	Issue of Data, Ephemeris	2, 3	N/A
ISF	Integrity Status Flag ^{NOTE1}	All	10
ω	Argument of Perigee	3	10
$\dot{\Omega}$	Rate of Right Ascension	3	N/A
$\Delta\dot{\Omega}$	Rate of Right Ascension Difference	N/A	11
Ω_0	Longitude of Ascending Node of Orbit Plane at Weekly Epoch	3	11
i_0	Inclination Angle at Reference Time	3	11
IDOT	Rate of Inclination Angle	3	11
C_{ic}	Amplitude of the Cosine Harmonic Correction Term to the Angle of Inclination	3	11
C_{is}	Amplitude of the Sine Harmonic Correction Term to the Angle of Inclination	3	11
C_{rc}	Amplitude of the Cosine Harmonic Correction Term to the Orbit Radius	3	11
ΔA	Semi-major Axis Difference at Reference Time	N/A	10

Symbol	Parameter Name	Subframe	Message
\dot{A}	Change Rate in Semi-major Axis	N/A	10
Δn_0	Mean Motion Difference from Computed Value at Reference Time	N/A	10
$\Delta \dot{n}_0$	Rate of Mean Motion Difference from Computed Value	N/A	10
(L1/L2/L5)	Signal Health (3 bits)	N/A	10
URA _{ED}	Elevation Dependent User Range Accuracy	N/A	10
ISC _{L1C/A}	Inter-signal Correction	N/A	30
ISC _{L2C}	Inter-signal Correction	N/A	30
ISC _{L5I5}	Inter-signal Correction	N/A	30
ISC _{L5Q5}	Inter-signal Correction	N/A	30
t _{op}	CEI Data Sequence Propagation Time of Week	N/A	10, 30-37
URA _{NED0}	NED Accuracy Index	N/A	30-37
URA _{NED1}	NED Accuracy Change Index	N/A	30-37
URA _{NED2}	NED Accuracy Change Rate Index	N/A	30-37
Alert	Alert Flag ^{NOTE1}	All	All

NOTE1: Parameters so indicated are for CEI Refinement – not limited to curve fit. Parameters not indicated are needed for/limited to curve fit.

Updates to parameters in table shall prompt changes in t_{oe}/t_{oc} for CNAV and t_{oe}/t_{oc}/IODC/IODE for LNAV. Any parameter marked with NOTE1 may be changed with or without a change in t_{oe}/t_{oc}/IODC/IODE.

IS200-2141:

Insertion after object IS200-2053

Section Number:

6.3.1.0-5

WAS:

<INSERTED OBJECT>

Redlines:

For GPS III and IIIIF SVs, the maximum received signal levels as a result of these factors are not expected to exceed -150.0 dBW for the P(Y) on the L1 and L2 channels, -153.0 dBW for C/A on the L1 channel, or -153.0 dBW for L2C on the L2 channel. In addition, due to programmable power output capabilities of GPS III and IIIIF SVs under certain operational scenarios, the maximum received signal levels are not expected to exceed -150 dBW.

Object Type: [Info-Only](#)

IS:

For GPS III and IIIIF SVs, the maximum received signal levels as a result of these factors are not expected to exceed -150.0 dBW for the P(Y) on the L1 and L2 channels, -153.0 dBW for C/A on the L1 channel, or -153.0 dBW for L2C on the L2 channel. In addition, due to programmable power output capabilities of GPS III and IIIIF SVs under certain operational scenarios, the maximum received signal levels are not expected to exceed -150 dBW.

Object Type: Info-Only

IS200-1334:

Section Number:

6.4.3

WAS:

Object Heading 6.4.3 PRNs 33 and 37

Redlines:

Object Heading 6.4.3 ~~PRNs~~ PRN 33 ~~and 37~~

IS:

Object Heading 6.4.3 PRN 33

IS200-1335:

Section Number:

6.4.3.0-1

WAS:

PRN 33 should not be used by satellites because of its prior use in specialized ground applications. PRN 37 should not be used by satellites until after PRN 37 is no longer needed for SATZAP purposes.

Redlines:

~~PRN~~ Currently, 33 the control segment should not ~~be~~ command ~~used~~ PRN by 33 for satellites because of its prior use in specialized ground applications. Future users should include PRN ~~37~~ 33 ~~should~~ tracking ~~not~~ capability ~~be~~ in used receivers ~~by~~ and satellites ~~be~~ unable ~~after~~ to use PRN ~~37~~ 33 ~~is~~ if ~~no~~ it ~~longer~~ is ~~needed~~ included ~~for~~ in SATZAP ~~the purposes~~ broadcast almanac.

IS:

Currently, the control segment should not command PRN 33 for satellites because of its prior use in specialized ground applications. Future users should include PRN 33 tracking capability in receivers and be able to use PRN 33 if it is included in the broadcast almanac.

IS200-1760:

Section Number:

6.4.6.2.2.0-1

WAS:

The following alarm indications are specific to the code signals listed below.

C/A-Code or P(Y)-Code Signal

- (a) The failure of parity on 5 successive words of LNAV data (3 seconds) (see paragraphs 20.3.5 and 40.3.5). (See Note 5)
- (b) The broadcast IODE does not match the 8 LSBs of the broadcast IODC (excluding normal data set cutovers, see paragraph 20.3.3.4.1).
- (c) The transmitted bits in words 3-10 in subframe 1, 2, or 3 are all set to 0's or all set to 1's.
- (d) Default LNAV data is being transmitted in subframes 1, 2, or 3 (see paragraph 20.3.2).
- (e) The 8-bit preamble does not equal 10001011₂, decimal 139, or hexadecimal 8B (see paragraph 20.3.3).

CM-Code Signal

- (a) The failure of the cyclic redundancy check (CRC) on 5 successive CNAV messages (60 seconds) (see paragraph 30.3.5).
- (b) The broadcast time of ephemeris (t_{oe}) is not current (i.e. not within the current curve-fit) or does not match the broadcast time of clock (t_{oc}) (excluding normal data set cutovers, see paragraphs 30.3.3.1.1 and 30.3.4.4).
- (c) The broadcast t_{op} is not consistent across the Message Types 10, 11 and Type 30's messages which comprise the current (i.e. not within the current curve-fit) CEI data set (excluding normal data set cutovers, see paragraph 30.3.4.4).
- (d) The transmitted bits (bits 39-276) in Message Types 10, 11 and Type 30's are all set to 0's or all set to 1's.
- (e) The 8-bit preamble does not equal 10001011₂, decimal 139, or hexadecimal 8B (see paragraph 30.3.3).

Notes:

1. A SIS alarm indication exists when the satellite is not trackable because it is not transmitting the standard PRN code modulation on the L-band carrier signal. These SIS alarm indications are specifically called out above because of their relatively high probability of occurrence.
2. The SIS alarm indications related to the LNAV and CNAV message data are considered "weak" indications since receivers do not necessarily continuously read each satellite's LNAV or CNAV message data either by design or by circumstance (e.g., radio-frequency interference [RFI] can prevent reading LNAV or CNAV message data). These weak SIS alarm indications are assumed to have a five-minute lag time before receivers take notice of them for alerting purposes.
3. The SIS alarm indications related to the LNAV or CNAV message data are indicative of a problem onboard the satellite. GPS receivers may perceive similar indications caused by local effects that are unrelated to the broadcast SIS.

4. *In addition to SIS alarm indications, other conditions may also cause GPS signals to become temporarily untrackable, such as ionospheric signal fades, local signal masking, or local interference.*
5. *Alarm indication (see C/A-Code or P(Y)-Code Signal (a)) does not apply to the default navigation data described in paragraph 20.3.2, when in subframes 4 or 5. Application of the user parity algorithm at paragraph 20.3.5.2 will result in failed parity checks for words 3-10 because the default LNAV data pattern is applied to bits 61-298.*

Redlines:

The following alarm indications are specific to the code signals listed below.

C/A-Code or P(Y)-Code Signal

- (a) The failure of parity on 5 successive words of LNAV data (3 seconds) (see paragraphs 20.3.5 and 40.3.5). (See Note 5)
- (b) The broadcast IODE does not match the 8 LSBs of the broadcast IODC (excluding normal data set cutovers, see paragraph 20.3.3.4.1).
- (c) ~~The Bits transmitted~~ 61 bits through 298 transmitted in words 3-10 in subframe 1, 2, or 3 are all set to 0's or all set to 1's.
- (d) Default LNAV data is being transmitted in subframes 1, 2, or 3 (see paragraph 20.3.2).
- (e) The 8-bit preamble does not equal 100010112, decimal 139, or hexadecimal 8B (see paragraph 20.3.3).

CM-Code Signal

- (a) The failure of the cyclic redundancy check (CRC) on 5 successive CNAV messages (60 seconds) (see paragraph 30.3.5).
- (b) The broadcast time of ephemeris (toe) is not current (i.e. not within the current curve-fit) or does not match the broadcast time of clock (toc) (excluding normal data set cutovers, see paragraphs 30.3.3.1.1 and 30.3.4.4).
- (c) The broadcast top is not consistent across the Message Types 10, 11 and Type 30's messages which comprise the current (i.e. not within the current curve-fit) CEI data set (excluding normal data set cutovers, see paragraph 30.3.4.4).
- (d) The transmitted bits (bits 39- through 276) in one or more of Message Types 10, 11 ~~and Type~~ or 30's through 37 are all set to 0's or all set to 1's.
- (e) The 8-bit preamble does not equal 100010112, decimal 139, or hexadecimal 8B (see paragraph 30.3.3).

Notes:

1. A SIS alarm indication exists when the satellite is not trackable because it is not transmitting the standard PRN code modulation on the L-band carrier signal. These SIS alarm indications are specifically called out above because of their relatively high probability of occurrence.
 2. The SIS alarm indications related to the LNAV and CNAV message data are considered “weak” indications since receivers do not necessarily continuously read each satellite’s LNAV or CNAV message data either by design or by circumstance (e.g., radio-frequency interference [RFI] can prevent reading LNAV or CNAV message data). These weak SIS alarm indications are assumed to have a five-minute lag time before receivers take notice of them for alerting purposes.
 3. The SIS alarm indications related to the LNAV or CNAV message data are indicative of a problem onboard the satellite. GPS receivers may perceive similar indications caused by local effects that are unrelated to the broadcast SIS.
 4. In addition to SIS alarm indications, other conditions may also cause GPS signals to become temporarily untrackable, such as ionospheric signal fades, local signal masking, or local interference.
- ~~Alarm~~5. An alarm indication (see C/A-Code or P(Y)-Code Signal (a)) does not apply to the default navigation data described in paragraph 20.3.2, when in subframes 4 or 5. Application of the user parity algorithm at paragraph 20.3.5.2 will result in failed parity checks for words 3-10 because the default LNAV data pattern is applied to bits

61- through 298. According to a) and d) default LNAV data broadcast in subframe 4 or in subframe 5 will not be considered as a do-not-use condition, and the user equipment may continue using the GPS L1 measurement as healthy so long as none of the other conditions leading to a GPS UNHEALTHY determination are present.

IS:

The following alarm indications are specific to the code signals listed below.

C/A-Code or P(Y)-Code Signal

- (a) The failure of parity on 5 successive words of LNAV data (3 seconds) (see paragraphs 20.3.5 and 40.3.5).
(See Note 5)
- (b) The broadcast IODE does not match the 8 LSBs of the broadcast IODC (excluding normal data set cutovers, see paragraph 20.3.3.4.1).
- (c) Bits 61 through 298 transmitted in words 3-10 in subframe 1, 2, or 3 are all set to 0's or all set to 1's.
- (d) Default LNAV data is being transmitted in subframes 1, 2, or 3 (see paragraph 20.3.2).
- (e) The 8-bit preamble does not equal 10001011₂, decimal 139, or hexadecimal 8B (see paragraph 20.3.3).

CM-Code Signal

- (a) The failure of the cyclic redundancy check (CRC) on 5 successive CNAV messages (60 seconds) (see paragraph 30.3.5).
- (b) The broadcast time of ephemeris (t_{oc}) is not current (i.e. not within the current curve-fit) or does not match the broadcast time of clock (t_{oc}) (excluding normal data set cutovers, see paragraphs 30.3.3.1.1 and 30.3.4.4).
- (c) The broadcast t_{op} is not consistent across the Message Types 10, 11 and Type 30's messages which comprise the current (i.e. not within the current curve-fit) CEI data set (excluding normal data set cutovers, see paragraph 30.3.4.4).
- (d) The transmitted bits (bits 39 through 276) in one or more of Message Types 10, 11 or 30 through 37 are all set to 0's or all set to 1's.
- (e) The 8-bit preamble does not equal 10001011₂, decimal 139, or hexadecimal 8B (see paragraph 30.3.3).

Notes:

1. A SIS alarm indication exists when the satellite is not trackable because it is not transmitting the standard PRN code modulation on the L-band carrier signal. These SIS alarm indications are specifically called out above because of their relatively high probability of occurrence.
2. The SIS alarm indications related to the LNAV and CNAV message data are considered "weak" indications since receivers do not necessarily continuously read each satellite's LNAV or CNAV message data either by design or by circumstance (e.g., radio-frequency interference [RFI] can prevent reading LNAV or CNAV message data). These weak SIS alarm indications are assumed to have a five-minute lag time before receivers take notice of them for alerting purposes.
3. The SIS alarm indications related to the LNAV or CNAV message data are indicative of a problem onboard the satellite. GPS receivers may perceive similar indications caused by local effects that are unrelated to the broadcast SIS.
4. In addition to SIS alarm indications, other conditions may also cause GPS signals to become temporarily untrackable, such as ionospheric signal fades, local signal masking, or local interference.
5. An alarm indication (see C/A-Code or P(Y)-Code Signal (a)) does not apply to the default navigation data described in paragraph 20.3.2, when in subframes 4 or 5. Application of the user parity algorithm at paragraph 20.3.5.2 will result in failed parity checks for words 3-10 because the default LNAV data pattern is applied to bits 61 through 298. According to a) and d) default LNAV data broadcast in subframe 4 or in subframe 5 will not be considered as a do-

not-use condition, and the user equipment may continue using the GPS L1 measurement as healthy so long as none of the other conditions leading to a GPS UNHEALTHY determination are present.

Section Number:

6.4.6.3.0-1

WAS:

The C/A-code signal is marginal when the C/A-code signal would otherwise have been defined as healthy except that one or more of the following three warning conditions is or are present:

1. The C/A-code signal indicates that any one of the satellite's SIS components may not be fully capable. More specifically, the Most Significant Bit (MSB) of the six-bit health status word given in subframe 1 of the LNAV message is set to 0_2 ("all LNAV data are OK") and the 5 Least Significant Bits (LSBs) of the six-bit health status word in subframe 1 of the LNAV message are set to anything other than 00000_2 (all signals are OK), 00010_2 (all signals dead), or 11100_2 ("SV is temporarily out"). See paragraphs 20.3.3.3.1.4 and 20.3.3.5.1.3.
2. The URA alert flag is raised (i.e., bit 18 of the LNAV HOW is set to 1) and the URA does not apply. This means the URA may be worse than the URA index value transmitted in subframe 1. See paragraph 20.3.3.2.
3. The transmitted URA index in subframe 1 is equal to 15 ("N"=15). See paragraph 20.3.3.3.1.3.

The health of the CM-code and CL-code signals is marginal when the signals would otherwise have been defined as healthy except that one or more of the following three warning conditions is or are present:

1. Default CNAV data (i.e., Message Type 0) is being transmitted in lieu of Message Type 10, 11 and/or Message Type 30's on the CM-code signal (e.g., a current and consistent CEI data set is not available within the maximum broadcast interval defined in paragraph 30.3.4.1). See paragraph 30.3.3.
2. The URA alert flag is raised (i.e., bit 38 of each CNAV message is set to 1) and therefore the CM-code signal URA components do not apply to the CM-code and CL-code signals. This means the CM-code and CL-code signal URA may be worse than indicated by the URA index components transmitted in Message Type 10 and Message Type 30's. See paragraph 30.3.3.
3. Either or both the URA_{ED} index in Message Type 10 and the URA_{NED0} index in Message Type 30's transmitted in the CM-code signal are equal to 15 or -16 ("N"=15 or "N"=-16). See paragraphs 30.3.3.1.1.4 and 30.3.3.2.4.

The P(Y)-code SIS health is marginal when the P(Y)-code SIS would otherwise have been defined as healthy except that one or more of the following three warning conditions is or are present:

1. The Most Significant Bit (MSB) of the six-bit health status word given in subframe 1 of the LNAV message is set to 0_2 and the 5 Least Significant Bits (LSBs) of the six-bit health status word in subframe 1 of the LNAV message are set to anything other than 00000_2 (all signals are OK), 00010_2 (all signals dead), or 11100_2 (SV is temporarily out). See paragraphs 20.3.3.3.1.4 and 20.3.3.5.1.3.
2. The URA alert flag transmitted as bit 18 of the HOW is set to 1 and the URA does not apply as defined in ICD-GPS-224 and ICD-GPS-225.
3. The transmitted URA index "N"=15.

A more restrictive 'marginal indications' (e.g., the transmitted URA index in Subframe 1 greater than or equal to 8) may apply in the context of specified minimum performance standards such as are given in the GPS Standard Positioning Service Performance Standard (SPS PS).

Redlines:

The C/A-code signal is marginal when the C/A-code signal would otherwise have been defined as healthy except that one or more of the following three warning conditions is or are present:

1. The C/A-code signal indicates that any one of the satellite's SIS components may not be fully capable. More specifically, the Most Significant Bit (MSB) of the six-bit health status word given in subframe 1 of the LNAV message is set to 02 ("all LNAV data are OK") and the 5 Least Significant Bits (LSBs) of the six-bit health status word in subframe 1 of the LNAV message are set to anything other than 000002 (all signals are OK), 000102 (all signals dead), or 111002 ("SV is temporarily out"). See paragraphs 20.3.3.3.1.4 and 20.3.3.5.1.3.
2. The URA alert flag is raised (i.e., bit 18 of the LNAV HOW is set to 1) and the URA does not apply. This means the URA may be worse than the URA index value transmitted in subframe 1. See paragraph 20.3.3.2.
3. The transmitted URA index in subframe 1 is equal to 15 ("N"=15). See paragraph 20.3.3.3.1.3.

The health of the CM-code and CL-code signals is marginal when the signals would otherwise have been defined as healthy except that one or more of the following three warning conditions is or are present:

~~Default CNAV data (i.e. 1., Message Type 0) is being transmitted in lieu of Message Type 10, 11 and/or Message Type 30's on The satellite CM-code does signal not (e.g., broadcast a current and consistent CEI data set is not within available three within times the maximum broadcast interval defined in paragraph 30.3.4.1). (see See Notes paragraph 1 30.3.3. and 2)~~

2. The URA alert flag is raised (i.e., bit 38 of each CNAV message is set to 1) and therefore the CM-code signal URA components do not apply to the CM-code and CL-code signals. This means the CM-code and CL-code signal URA may be worse than indicated by the URA index components transmitted in Message ~~Type Types~~ 10 and ~~Message 30~~ ~~Type through 30's 37~~. See paragraph 30.3.3.

3. Either or both the URAED index in Message Type 10 and the URANED0 index in Message ~~Type Types~~ 30's ~~through 37~~ transmitted in the CM-code signal are equal to 15 or -16 ("N"=15 or "N"=-16). See paragraphs 30.3.3.1.1.4 and 30.3.3.2.4.

Note 1: ~~Default CNAV data (i.e. Message Type 0) may be transmitted in lieu of any message type when the correct data for the message type is unavailable or when no other message is scheduled.~~

Note 2: ~~UE might be unable to confirm the satellite broadcast of a consistent data set when local conditions prevent correctly receiving and decoding a continuous set of messages.~~

The P(Y)-code SIS health is marginal when the P(Y)-code SIS would otherwise have been defined as healthy except that one or more of the following three warning conditions is or are present:

1. The Most Significant Bit (MSB) of the six-bit health status word given in subframe 1 of the LNAV message is set to 02 and the 5 Least Significant Bits (LSBs) of the six-bit health status word in subframe 1 of the LNAV message are set to anything other than 000002 (all signals are OK), 000102 (all signals dead), or 111002 (SV is temporarily out). See paragraphs 20.3.3.3.1.4 and 20.3.3.5.1.3.
2. The URA alert flag transmitted as bit 18 of the HOW is set to 1 and the URA does not apply as defined in ICD-GPS-224 and ICD-GPS-225.
3. The transmitted URA index "N"=15.

A more restrictive 'marginal indications' (e.g., the transmitted URA index in Subframe 1 greater than or equal to 8) may apply in the context of specified minimum performance standards such as are given in the GPS Standard Positioning Service Performance Standard (SPS PS).

IS:

The C/A-code signal is marginal when the C/A-code signal would otherwise have been defined as healthy except that one or more of the following three warning conditions is or are present:

1. The C/A-code signal indicates that any one of the satellite's SIS components may not be fully capable. More specifically, the Most Significant Bit (MSB) of the six-bit health status word given in subframe 1 of the LNAV message is set to 0_2 ("all LNAV data are OK") and the 5 Least Significant Bits (LSBs) of the six-bit health status word in subframe 1 of the LNAV message are set to anything other than 00000_2 (all signals are OK), 00010_2 (all signals dead), or 11100_2 ("SV is temporarily out"). See paragraphs 20.3.3.3.1.4 and 20.3.3.5.1.3.
2. The URA alert flag is raised (i.e., bit 18 of the LNAV HOW is set to 1) and the URA does not apply. This means the URA may be worse than the URA index value transmitted in subframe 1. See paragraph 20.3.3.2.
3. The transmitted URA index in subframe 1 is equal to 15 ("N"=15). See paragraph 20.3.3.3.1.3.

The health of the CM-code and CL-code signals is marginal when the signals would otherwise have been defined as healthy except that one or more of the following three warning conditions is or are present:

1. The satellite does not broadcast a current and consistent CEI data set within three times the maximum broadcast interval defined in paragraph 30.3.4.1. (see Notes 1 and 2)
2. The URA alert flag is raised (i.e., bit 38 of each CNAV message is set to 1) and therefore the CM-code signal URA components do not apply to the CM-code and CL-code signals. This means the CM-code and CL-code signal URA may be worse than indicated by the URA index components transmitted in Message Types 10 and 30 through 37. See paragraph 30.3.3.
3. Either or both the URA_{ED} index in Message Type 10 and the URA_{NED0} index in Message Types 30 through 37 transmitted in the CM-code signal are equal to 15 or -16 ("N"=15 or "N"=-16). See paragraphs 30.3.3.1.1.4 and 30.3.3.2.4.

Note 1: Default CNAV data (i.e. Message Type 0) may be transmitted in lieu of any message type when the correct data for the message type is unavailable or when no other message is scheduled.

Note 2: UE might be unable to confirm the satellite broadcast of a consistent data set when local conditions prevent correctly receiving and decoding a continuous set of messages.

The P(Y)-code SIS health is marginal when the P(Y)-code SIS would otherwise have been defined as healthy except that one or more of the following three warning conditions is or are present:

1. The Most Significant Bit (MSB) of the six-bit health status word given in subframe 1 of the LNAV message is set to 02 and the 5 Least Significant Bits (LSBs) of the six-bit health status word in subframe 1 of the LNAV message are set to anything other than 00000_2 (all signals are OK), 00010_2 (all signals dead), or 11100_2 (SV is temporarily out). See paragraphs 20.3.3.3.1.4 and 20.3.3.5.1.3.
2. The URA alert flag transmitted as bit 18 of the HOW is set to 1 and the URA does not apply as defined in ICD-GPS-224 and ICD-GPS-225.
3. The transmitted URA index "N"=15.

A more restrictive 'marginal indications' (e.g., the transmitted URA index in Subframe 1 greater than or equal to 8) may apply in the context of specified minimum performance standards such as are given in the GPS Standard Positioning Service Performance Standard (SPS PS).

IS200-2142:

Insertion after object IS200-1761

Section Number:

6.4.6.4

WAS:

<INSERTED OBJECT>

Redlines:

Object Heading 6.4.6.4 [Data ID Numbers Other Than 2](#)

Object Type: [Header](#)

IS:

Object Heading 6.4.6.4 Data ID Numbers Other Than 2

Object Type: Header

IS200-2143:

Insertion below object IS200-2142

Section Number:

6.4.6.4.0-1

WAS:

<INSERTED OBJECT>

Redlines:

[The recommended user protocol is to determine the Data ID before decoding and using LNAV data. The broadcast of future data structures with Data ID numbers other than 2 will not impact LNAV Data ID 2 performance commitments for user equipment that does not follow this recommendation.](#)

Object Type: [Info-Only](#)

IS:

The recommended user protocol is to determine the Data ID before decoding and using LNAV data. The broadcast of future data structures with Data ID numbers other than 2 will not impact LNAV Data ID 2 performance commitments for user equipment that does not follow this recommendation.

Object Type: Info-Only

IS200-320:

Section Number:

20.3.3.3.1.3.0-5

WAS:

For each URA index (N), users may compute a nominal URA value (X) as given by:

- If the value of N is 6 or less, $X = 2(1 + N/2)$,
- If the value of N is 6 or more, but less than 15, $X = 2(N - 2)$,
- N = 15 shall indicate the absence of an accuracy prediction and shall advise the standard positioning service user to use that SV at his own risk.

Redlines:

For each URA index (N), users may compute a nominal URA value (X) as given by:

- If the value of N is 6 or less, $X = 2(\del{1 + N/2})^{\del{1 + N/2}}$,
- If the value of N is 6 or more, but less than 15, $X = 2(\del{N - 2})^{\del{N - 2}}$,
- N = 15 shall indicate the absence of an accuracy prediction and shall advise the standard positioning service user to use that SV at his own risk.

IS:

For each URA index (N), users may compute a nominal URA value (X) as given by:

- If the value of N is 6 or less, $X = 2^{(1 + N/2)}$,
 - If the value of N is 6 or more, but less than 15, $X = 2^{(N - 2)}$,
 - N = 15 shall indicate the absence of an accuracy prediction and shall advise the standard positioning service user to use that SV at his own risk.
-

IS200-387:

Section Number:

20.3.3.5.1.1.0-1

WAS:

The two MSBs of word three in each page shall contain data ID. Data ID number two (denoted by binary code 01) denotes the LNAV data structure of D(t) which is described in this Appendix and is the only valid value.

Redlines:

The two MSBs of word three in each page shall contain ~~e~~Data ID. Data ID number two (denoted by binary code 01) denotes the LNAV data structure of D(t) which is described in this Appendix ~~and is the only valid value.~~

IS:

The two MSBs of word three in each page shall contain Data ID. Data ID number two (denoted by binary code 01) denotes the LNAV data structure of D(t) which is described in this Appendix.

IS200-2090:

Section Number:

20.3.4.1.0-3

WAS:

Cutovers to newly updated data for subframes 1, 2, and 3 occur on frame boundaries (i.e., modulo 30 seconds relative to end/start of week). Newly updated data for subframes 4 and 5 may start to be transmitted with any of the 25 pages of these subframes.

Redlines:

~~Cutovers~~[For Block IIF, GPS III/IIIF and all future SVs, cutovers](#) to newly updated data for subframes 1, 2, and 3 occur on frame boundaries (i.e., modulo 30 seconds relative to end/start of week). Newly updated data for subframes 4 and 5 may start to be transmitted with any of the 25 pages of these subframes.

IS:

For Block IIF, GPS III/IIIF and all future SVs, cutovers to newly updated data for subframes 1, 2, and 3 occur on frame boundaries (i.e., modulo 30 seconds relative to end/start of week). Newly updated data for subframes 4 and 5 may start to be transmitted with any of the 25 pages of these subframes.

IS200-523:

Section Number:

30.3.3.0-16

WAS:

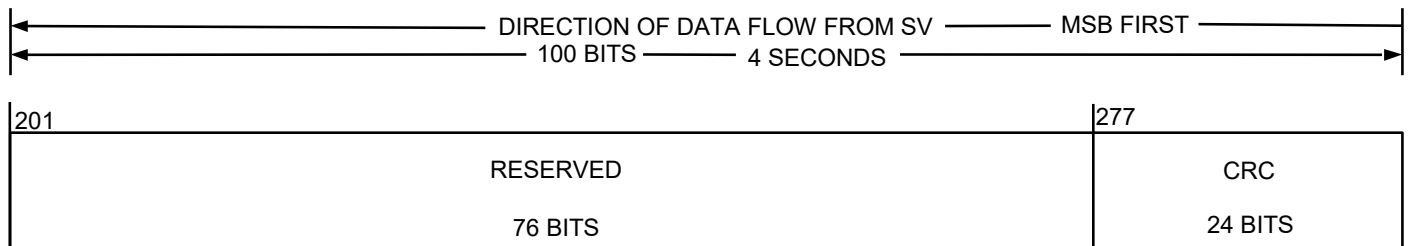
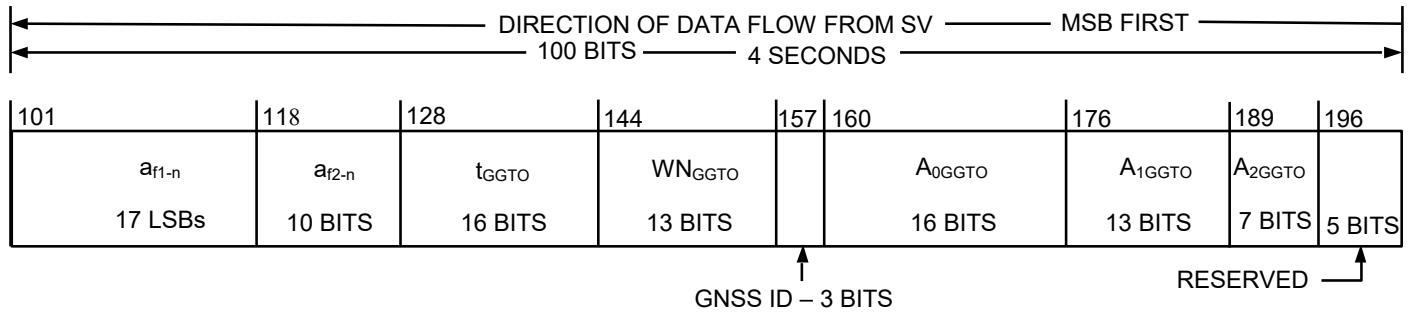
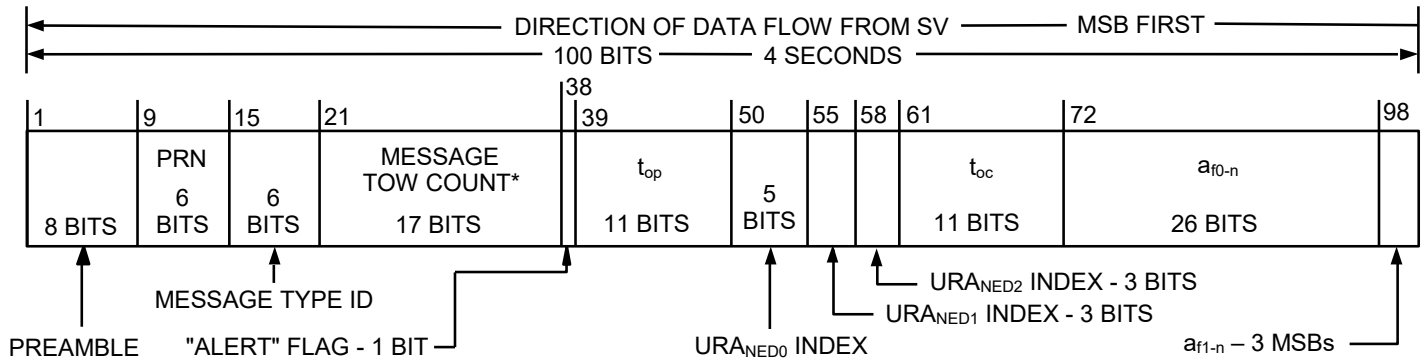

* MESSAGE TOW COUNT = 17 MSB OF ACTUAL TOW COUNT AT START OF NEXT 12-SECOND MESSAGE

Redlines: <not available graphically>

- The GNSS ID field was renamed GGTO ID near the middle of the figure.

IS:

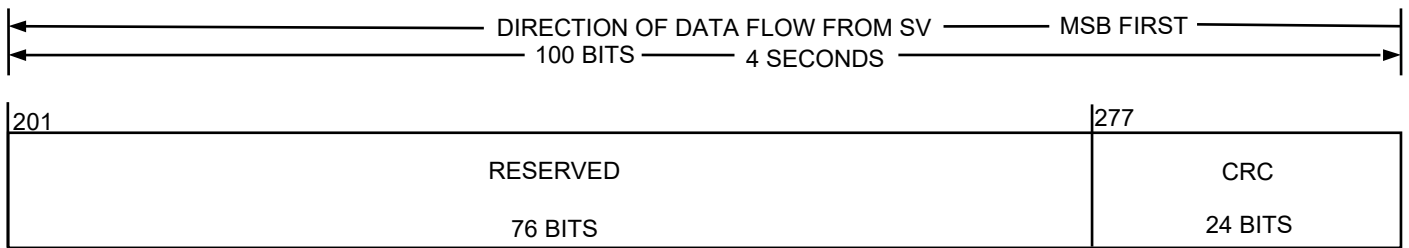
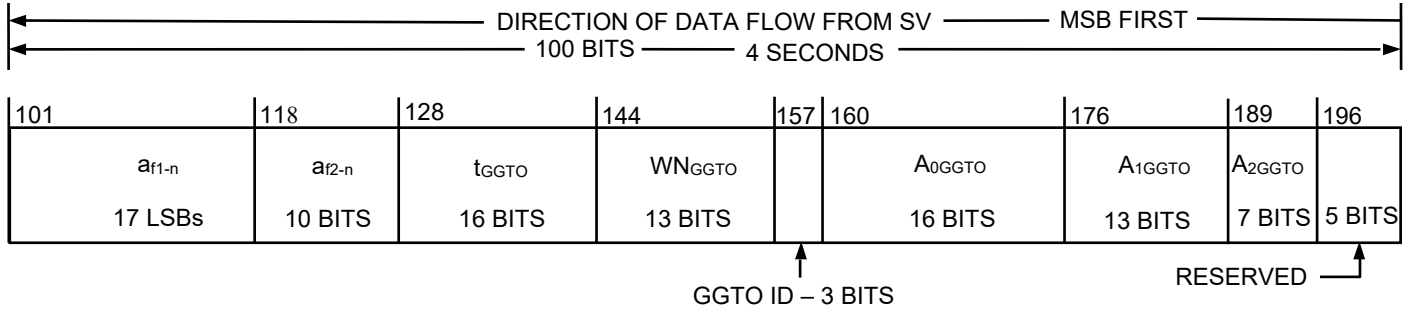
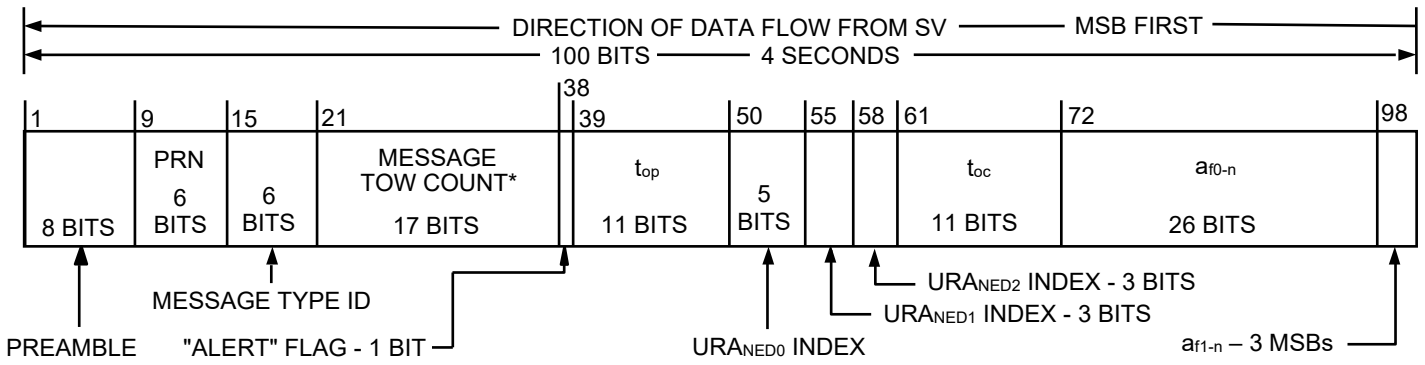

* MESSAGE TOW COUNT = 17 MSB OF ACTUAL TOW COUNT AT START OF NEXT 12-SECOND MESSAGE

IS200-552:

Section Number:

30.3.3.1.3.0-5

WAS:

Parameter		No. of Bits**	Scale Factor (LSB)	Valid Range***	Units
WN	Data Sequence Propagation Week Number	13	1		weeks
UR _{AED} Index	ED Accuracy Index	5*			(see text)
Signal health (L1/L2/L5)		3	1		(see text)
t _{op}	CEI Data sequence propagation time of week	11	300	0 to 604,500	seconds
ΔA ****	Semi-major axis difference at reference time	26*	2 ⁻⁹		meters
\dot{A}	Change rate in semi-major axis	25*	2 ⁻²¹		meters/sec
Δn ₀	Mean Motion difference from computed value at reference time	17*	2 ⁻⁴⁴		semi-circles/sec
$\dot{\Delta n}_0$	Rate of mean motion difference from computed value	23*	2 ⁻⁵⁷		semi-circles/sec ²
M _{0-n}	Mean anomaly at reference time	33*	2 ⁻³²		semi-circles
e _n	Eccentricity	33	2 ⁻³⁴	0.0 to 0.03	dimensionless
ω _n	Argument of perigee	33*	2 ⁻³²		semi-circles

* Parameters so indicated are two's complement, with the sign bit (+ or -) occupying the MSB;
 ** See Figure 30-1 for complete bit allocation in Message Type 10;
 *** Unless otherwise indicated in this column, valid range is the maximum range attainable with indicated bit allocation and scale factor.
 **** Relative to A_{REF} = 26,559,710 meters.

Redlines:

Parameter		No. of Bits**	Scale Factor (LSB)	Valid Range***	Units
WN	Data Sequence Propagation Week Number	13	1		weeks
URA _{ED} Index	ED Accuracy Index	5*			(see text)
Signal health (L1/L2/L5)		3	1		(see text)
t _{op}	CEI Data sequence propagation time of week	11	300	0 to 604,500	seconds
ΔA ****	Semi-major axis difference at reference time	26*	2 ⁻⁹		meters
• A	Change rate in semi-major axis	25*	2 ⁻²¹		meters/sec
Δn ₀	Mean Motion difference from computed value at reference time	17*	2 ⁻⁴⁴		semi-circles/sec
• Δn ₀	Rate of mean motion difference from computed value	23*	2 ⁻⁵⁷		semi-circles/sec ²
M _{0-n}	Mean anomaly at reference time	33*	2 ⁻³²		semi-circles
e _n	Eccentricity	33	2 ⁻³⁴	0.0 to 0.03	dimensionless
ω _n	Argument of perigee	33*	2 ⁻³²		semi-circles
<p>* Parameters so indicated are two's complement, with the sign bit (+ or -) occupying the MSB; ** See Figure 30-1 for complete bit allocation in Message Type 10; *** Unless otherwise indicated in this column, valid range is the maximum range attainable with indicated bit allocation and scale factor. **** Relative to A_{REF} = 26,559,710 meters.</p>					

IS:

Parameter		No. of Bits**	Scale Factor (LSB)	Valid Range***	Units
WN	Week Number	13	1		weeks
URA _{ED} Index	ED Accuracy Index	5*			(see text)
Signal health (L1/L2/L5)		3	1		(see text)
t _{op}	CEI Data sequence propagation time of week	11	300	0 to 604,500	seconds
ΔA ****	Semi-major axis difference at reference time	26*	2 ⁻⁹		meters
• _A	Change rate in semi-major axis	25*	2 ⁻²¹		meters/sec
Δn ₀	Mean Motion difference from computed value at reference time	17*	2 ⁻⁴⁴		semi-circles/sec
• _{Δn₀}	Rate of mean motion difference from computed value	23*	2 ⁻⁵⁷		semi-circles/sec ²
M _{0-n}	Mean anomaly at reference time	33*	2 ⁻³²		semi-circles
e _n	Eccentricity	33	2 ⁻³⁴	0.0 to 0.03	dimensionless
Ω _n	Argument of perigee	33*	2 ⁻³²		semi-circles
<p>* Parameters so indicated are two's complement, with the sign bit (+ or -) occupying the MSB; ** See Figure 30-1 for complete bit allocation in Message Type 10; *** Unless otherwise indicated in this column, valid range is the maximum range attainable with indicated bit allocation and scale factor. **** Relative to A_{REF} = 26,559,710 meters.</p>					

IS200-2102:

Section Number:

30.3.3.8.1.0-2

WAS:

Bits 157 through 159 of Message Type 35 shall identify the other GPS like navigation system to which the offset data applies. The three bits are defined as follows;

000 = no data available,

001 = Galileo,

010 = GLONASS,

011 through 111 = Reserved in order to preserve use of these values in a future revision of this IS. Until such a revision, the User Segment developing to this version of this IS should interpret these values as indicating that the GPS/GNSS Time Offset Parameter data, to which the GNSS Type ID applies, is presently unusable.

Redlines:

Bits 157 through 159 of Message Type 35 shall identify the other GPS like navigation system to which the offset data applies. The three bits are defined as follows:

000 = no data available,

001 = Galileo,

010 = GLONASS,

011 through 111 = Reserved in order to preserve use of these values in a future revision of this IS. Until such a revision, the User Segment developing to this version of this IS should interpret these values as indicating that the GPS/GNSS Time Offset Parameter data, to which the ~~GNSS Type~~ [GGTO](#) ID applies, is presently unusable.

IS:

Bits 157 through 159 of Message Type 35 shall identify the other GPS like navigation system to which the offset data applies. The three bits are defined as follows:

000 = no data available,

001 = Galileo,

010 = GLONASS,

011 through 111 = Reserved in order to preserve use of these values in a future revision of this IS. Until such a revision, the User Segment developing to this version of this IS should interpret these values as indicating that the GPS/GNSS Time Offset Parameter data, to which the GGTO ID applies, is presently unusable.

IS200-663:

Section Number:

30.3.3.8.2.0-3

WAS:

Parameter		No. of Bits**	Scale Factor (LSB)	Valid Range***	Units
A _{0GGTO}	Bias coefficient of GPS time scale relative to GNSS time scale	16*	2 ⁻³⁵		seconds
A _{1GGTO}	Drift coefficient of GPS time scale relative to GNSS time scale	13*	2 ⁻⁵¹		sec/sec
A _{2GGTO}	Drift rate correction coefficient of GPS time scale relative to GNSS time scale	7*	2 ⁻⁶⁸		sec/sec ²
t _{GGTO}	Time data reference Time of Week	16	2 ⁴	0 to 604,784	seconds
W _{NGGTO}	Time data reference Week Number	13	2 ⁰		weeks
GNSS ID	GNSS Type ID	3			see text
<p>* Parameters so indicated shall be two's complement with the sign bit (+ or -) occupying the MSB;</p> <p>** See Figure 30-8 for complete bit allocation;</p> <p>*** Unless otherwise indicated in this column, valid range is the maximum range attainable with indicated bit allocation and scale factor.</p>					

Redlines:

Parameter		No. of Bits**	Scale Factor (LSB)	Valid Range***	Units
A _{0GGTO}	Bias coefficient of GPS time scale relative to GNSS time scale	16*	2 ⁻³⁵		seconds
A _{1GGTO}	Drift coefficient of GPS time scale relative to GNSS time scale	13*	2 ⁻⁵¹		sec/sec
A _{2GGTO}	Drift rate correction coefficient of GPS time scale relative to GNSS time scale	7*	2 ⁻⁶⁸		sec/sec ²
t _{GGTO}	Time data reference Time of Week	16	2 ⁴	0 to 604,784	seconds
WN _{GGTO}	Time data reference Week Number	13	2 ⁰		weeks
<u>GGTO</u> GNSS ID	<u>GGTO</u> GNSS Type ID	3			see text
<p>* Parameters so indicated shall be two's complement with the sign bit (+ or -) occupying the MSB;</p> <p>** See Figure 30-8 for complete bit allocation;</p> <p>*** Unless otherwise indicated in this column, valid range is the maximum range attainable with indicated bit allocation and scale factor.</p>					

IS:

Parameter		No. of Bits**	Scale Factor (LSB)	Valid Range***	Units
A _{0GGTO}	Bias coefficient of GPS time scale relative to GNSS time scale	16*	2 ⁻³⁵		seconds
A _{1GGTO}	Drift coefficient of GPS time scale relative to GNSS time scale	13*	2 ⁻⁵¹		sec/sec
A _{2GGTO}	Drift rate correction coefficient of GPS time scale relative to GNSS time scale	7*	2 ⁻⁶⁸		sec/sec ²
t _{GGTO}	Time data reference Time of Week	16	2 ⁴	0 to 604,784	seconds
WN _{GGTO}	Time data reference Week Number	13	2 ⁰		weeks
GGTO ID	GGTO Type ID	3			see text
<p>* Parameters so indicated shall be two's complement with the sign bit (+ or -) occupying the MSB;</p> <p>** See Figure 30-8 for complete bit allocation;</p> <p>*** Unless otherwise indicated in this column, valid range is the maximum range attainable with indicated bit allocation and scale factor.</p>					

IS200-669:

Section Number:

30.3.4.1.0-1

WAS:

Broadcast system of messages is completely arbitrary, but sequenced to provide optimum user performance. Message Types 10 and 11 shall be broadcast at least once every 48 seconds.

Redlines:

~~Broadcast~~The system broadcast schedule of messages CNAV message types is completely arbitrary, but sequenced to provide optimum user performance. - Message ~~Types~~types 10, 11, and ~~H~~a clock message shall be broadcast at least once every 60 seconds (with a nominal rate of 48 seconds) to provide system users the clock, ephemeris and integrity (CEI) data needed to access GPS. Among the broadcast clock messages, an MT 30 message will be broadcast at least once every 300 seconds. Other message types may not be broadcast, but when they are scheduled for broadcast, they will be broadcast in between these CEI messages. If a message type is scheduled for broadcast on L2C from a satellite, that satellite will broadcast that message type on L2C at least every 20 minutes, unless a message generation failure results in its replacement with a Message Type 0. Message types with constellation data (like almanac and differential corrections) will cycle through any allotted broadcast slots in these 20-minute intervals, and therefore, will take longer than 20 minutes to complete the broadcast of the entire data set. CNAV message broadcast schedules may differ between satellites, and between L2C and L5I on the same satellite.

IS:

The broadcast schedule of CNAV message types is completely arbitrary but sequenced to provide optimum user performance. Message types 10, 11, and a clock message shall be broadcast at least once every 60 seconds (with a nominal rate of 48 seconds) to provide system users the clock, ephemeris and integrity (CEI) data needed to access GPS. Among the broadcast clock messages, an MT 30 message will be broadcast at least once every 300 seconds. Other message types may not be broadcast, but when they are scheduled for broadcast, they will be broadcast in between these CEI messages. If a message type is scheduled for broadcast on L2C from a satellite, that satellite will broadcast that message type on L2C at least every 20 minutes, unless a message generation failure results in its replacement with a Message Type 0. Message types with constellation data (like almanac and differential corrections) will cycle through any allotted broadcast slots in these 20-minute intervals, and therefore, will take longer than 20 minutes to complete the broadcast of the entire data set. CNAV message broadcast schedules may differ between satellites, and between L2C and L5I on the same satellite.

IS200-2103:

Section Number:

30.3.4.1.0-2

WAS:

All other messages shall be broadcast in-between, not exceeding the maximum broadcast interval in Table 30-XII. Message Type 15 will be broadcast as needed, but will not reduce the maximum broadcast interval of the other messages. Type 15 messages that are longer than one page will not necessarily be broadcast consecutively.

Redlines:

~~All other messages shall be broadcast in-between, not exceeding the maximum broadcast interval in Table 30-XII. Message Type 15 will be broadcast as needed, but will not reduce the maximum broadcast interval of the other messages. Type and 1536~~ messages that are longer than one text page will not necessarily be broadcast consecutively.

IS:

Message Type 15 and 36 messages that are longer than one text page will not necessarily be broadcast consecutively.

IS200-1624:

Section Number:

30.3.4.1.0-3

WAS:

Table 30-XII. Message Broadcast Intervals

Redlines:

Table 30-XII. ~~Message Broadcast Intervals~~RESERVED

IS:

Table 30-XII. RESERVED

IS200-670:

Section Number:

30.3.4.1.0-4

WAS:

Message Data	Message Type Number	Maximum Broadcast Intervals †
Ephemeris	10 & 11	48 sec
Clock	Type 30's	48 sec
ISC, IONO	30*	288 sec
Reduced Almanac	31* or 12	20 min**,****
Midi Almanac	37*	120 min**,****
EOP	32*	30 min****
UTC	33*	288 sec
Diff Correction	34* or 13 & 14	30 min***,****
GGTO	35*	288 sec****
Text	36* or 15	As needed****
Integrity Support Message+	40	288 sec ****

* Also contains SV clock correction parameters.
** Complete set of SVs in the constellation.
*** When Differential Corrections are available.
**** Optional (interval applies if/when broadcast).
+ One ISM per maximum broadcast interval; However, users are not required but can accept multiple ISMs from any SVs. Users can refer to the future TSO and MSO for further details.
† The intervals specified are maximum. As such, the broadcast intervals may be shorter than the specified value.

Redlines:

<DELETED OBJECT>

IS:

<DELETED OBJECT>

IS200-1371:

Section Number:

40.3.3.5.1.1.0-1

WAS:

The two MSBs of word three in each page shall contain the data ID. Data ID number two (denoted by binary code 01) denotes the LNAV data structure of D(t) which is described in this Appendix and is the only valid value.

Redlines:

The two MSBs of word three in each page shall contain the data ID. Data ID number two (denoted by binary code 01) denotes the LNAV data structure of D(t) which is described in this Appendix ~~and is the only valid value.~~

IS:

The two MSBs of word three in each page shall contain the data ID. Data ID number two (denoted by binary code 01) denotes the LNAV data structure of D(t) which is described in this Appendix.
